

1. Assign a location for the equipment considering the space requirements (impact area).
2. Excavate soil for foundations of starting point and terminus, according to drawing.  
Please note: To achieve maximum stability and safe installation, a moderate level of soil solubility is indispensable.
3. Due to the danger of overstraining the tube bends of the posts, we recommend to begin with mounting two posts to each crossbeam (see figure "Installation of supports"). Raise the unit by using an appropriate lifting gear and put assembly into foundation holes after mounting the reinforcement cages. Support temporarily, in accordance with all security-relevant rules. Afterwards mount the remaining two posts as well as the reinforcement cages to the crossbeam.
4. Screw two ramp tubes to supports of starting station acc. to drawing.
5. Align wooden platform and ramp on the mounting links (pre-drilled holes  $\varnothing 8$  in platform bearer) and fasten platform.
6. Align starting point and terminus and grout foundations (according to drawing) with compressed concrete C20/25. Lift up reinforcement and ensure a concrete covering of at least 5 cm.
7. The impact attenuating surface within the impact area (see ground view) shall at least conform to the minimum values for a critical fall height of 1000 mm (see EN 1176-4).
8. For wire cable forwarding, please complete attached form "Measurement on site" and return sheet to your distributor or to K&K Freizeitgeräte.

After setting of concrete foundations: (see figure "Installation of wire cable")

9. For cable assembly, the tensioning device mounted to the crossbeam of the terminus must be relaxed as follows: remove protective cap from tensioning device by loosening the set screws by an Allen key 6 mm across-flats.  
Extend the tensioning device to the stop by a spanner jaw size 36 mm.
10. Hang up cable with traveller: Remove hexagon head screw from cable socket (24 mm across-flats), match ends of cable socket with fixing hole at end of tensioning device, reinsert screw and fix it with a prevailing torque type nut.  
Attention: Tighten the screw such that the cable socket barely remains flexible.  
Perform that procedure both at the starting point and at the terminus.
11. Tension the cable such that the pendulum seat (with a load of 69,5 kg) keeps ground clearance of at least 0,35 m (according to EN 1176-4). If necessary, shorten length of seat chain above the handle. Do not fall below the minimum length of 1,80 m for chain including handle.
12. To make sure a proper course of the traveller on the cable, the lateral impact plates of the traveller are vertically adjustable to avoid tilting or abrasion of the cable.
13. Check all screw connections and cable tension according to maintenance instructions after 4-5 weeks and retighten, if necessary. Afterwards, cover the screw heads with protective caps (included in delivery).

Tools: lifting gear (for approx. 0,5 t)  
ladder, spanner, Allen key

Minimum/maximum wire cable sag:

sag = vertical distance from

- imaginary line between cable suspension points (K&K: from centre to centre of wedge sockets) and
- centre of sagging wire cable measured at low point

minimum sag: 7 cm (without load)

maximum sag: 9 cm (without load)

maximum gradient permitted:

$\Delta h=1,00$  m

impact area

(area marked by dashed line, see ground view)

area = 145 m<sup>2</sup>

free height of fall = 0,55 m

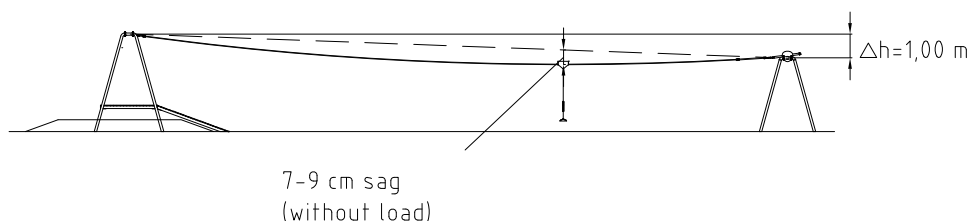
Instructions on (re-)adjusting the wire cable:

1. Remove protective cap from tensioning device by loosening four set screws by means of an Allen key 6 mm across-flats.
2. Turn hexagon nut by means of a spanner jaw size 36 mm, direction corresponding to intended effect.

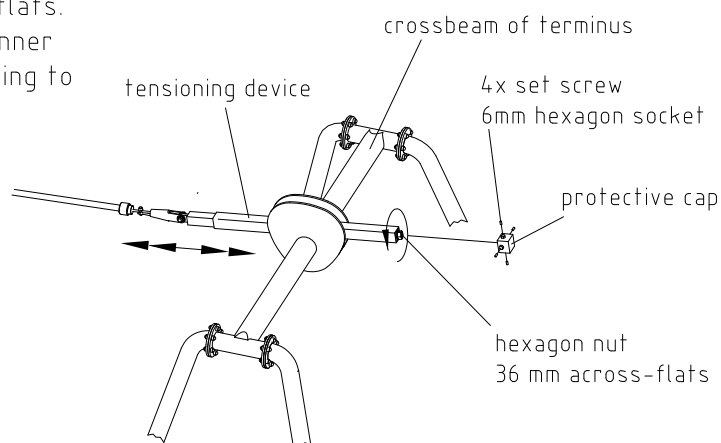

Please ensure that all special tools supplied and all specific documents which are or may be useful for safety management according to EN 1176-7 (e.g. invoice, delivery note, order acknowledgement, installation and maintenance instructions) are forwarded to the persons responsible.

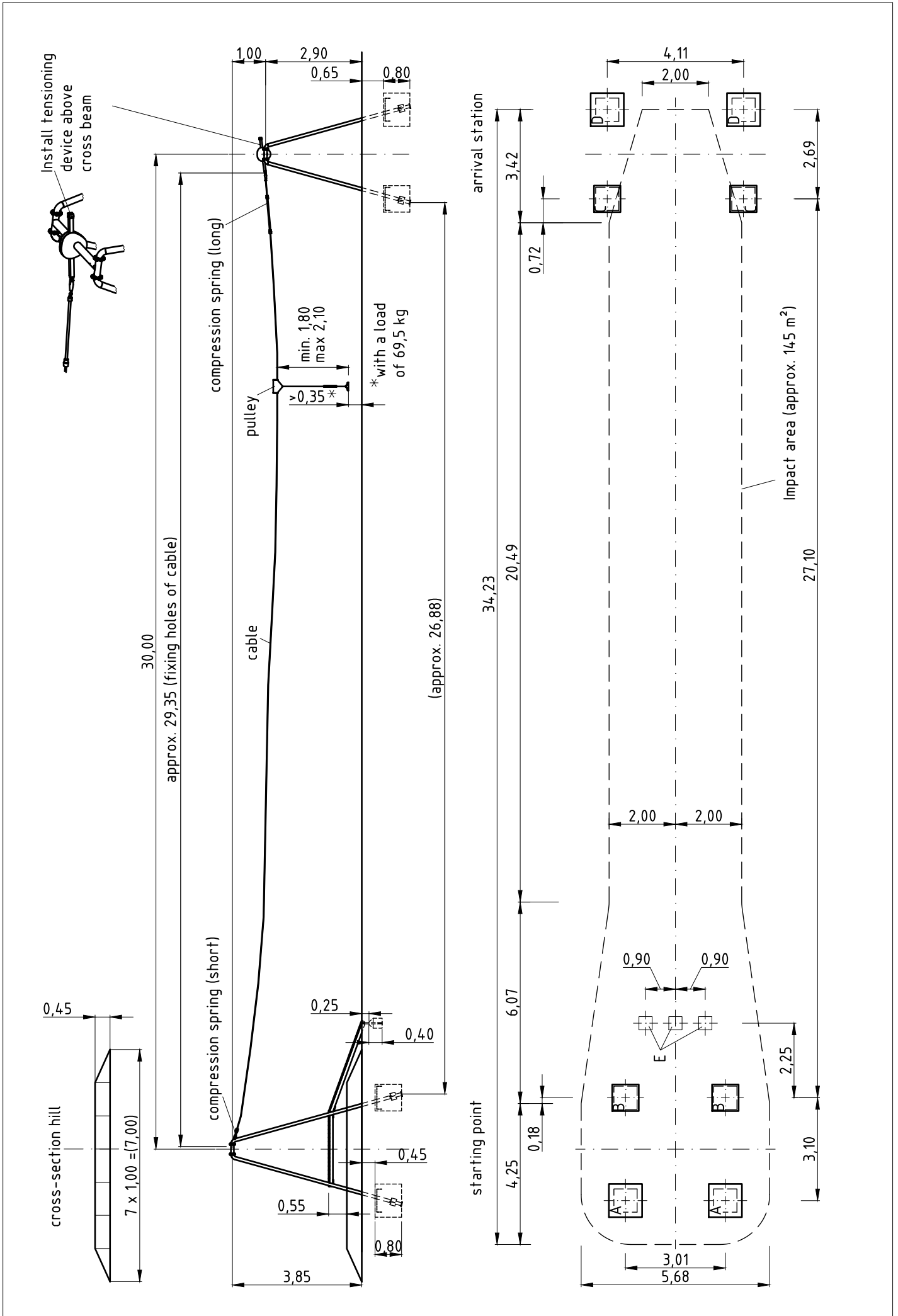

# Installation

foundation type A

outer support of starting station

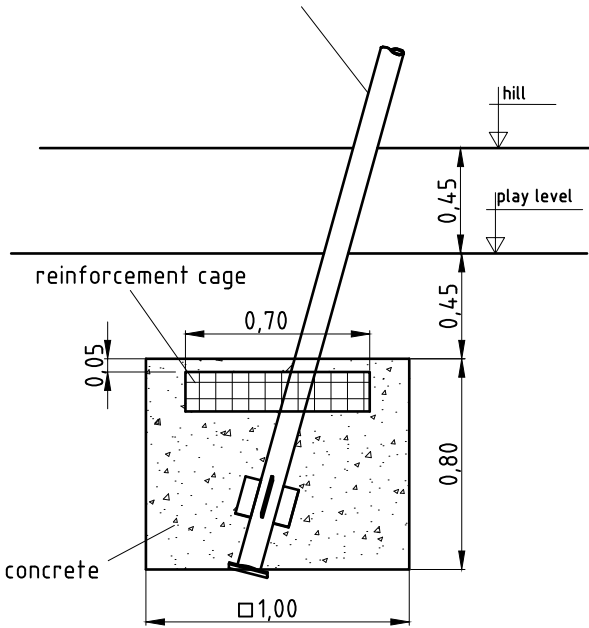

foundation type B

inner support of starting station

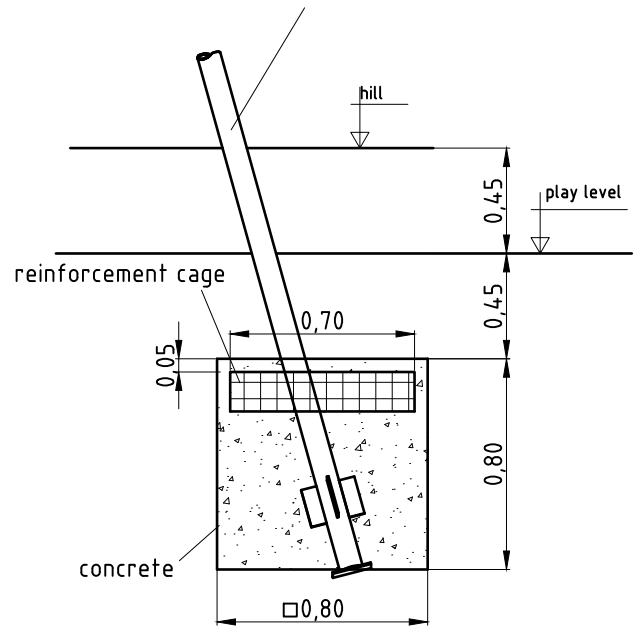

foundation type C

inner support of terminus

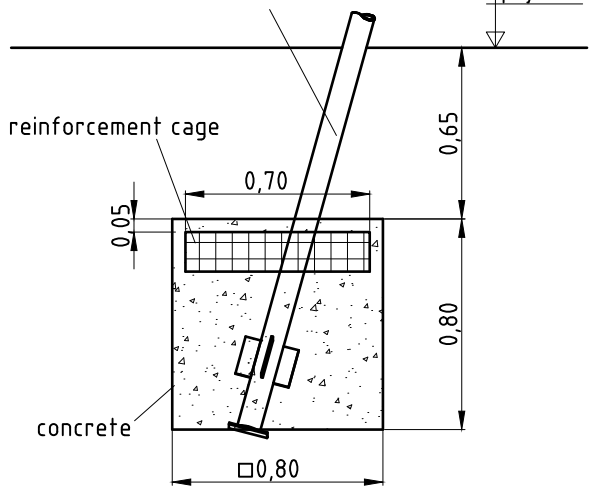

foundation type D

outer support of terminus

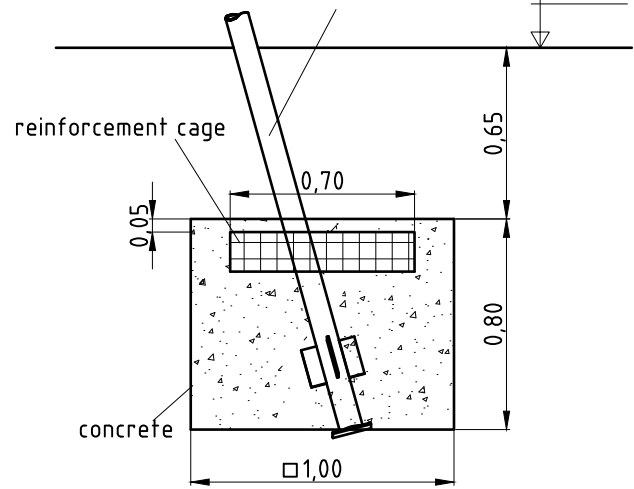

foundation type E

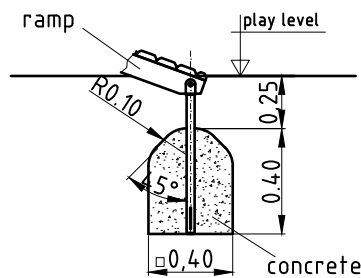

### Installation of supports:

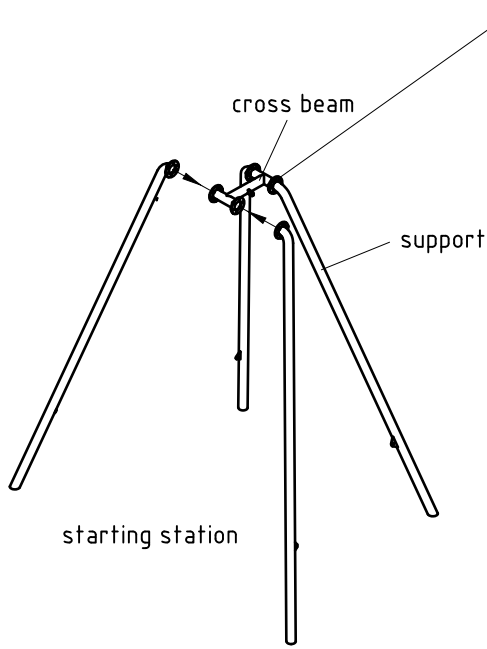

**48 x screw connection**  
 consisting of:  
 hexagon head screw  
 DIN 933-M12x40-zinc-coated;  
 prevailing torque type hexagon domed cap nut  
 DIN 986-M12-zinc-coated.;  
 grey protecting cap SKS 12

First mount two steel supports  
 to cross beam, raise and put  
 unit into foundation holes with  
 placing reinforcement cage.

Afterwards mount the  
 remaining two steel supports.

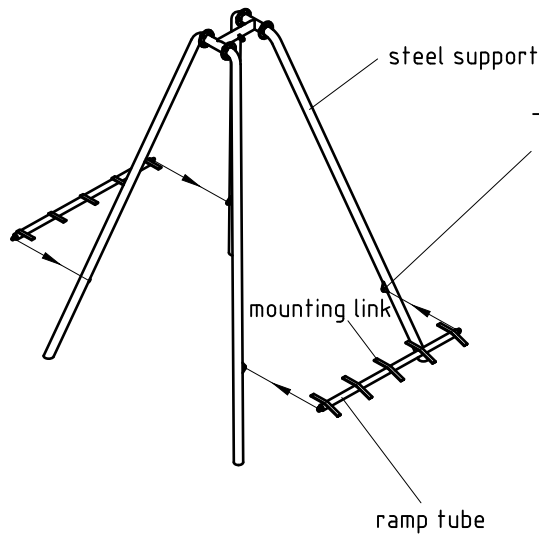
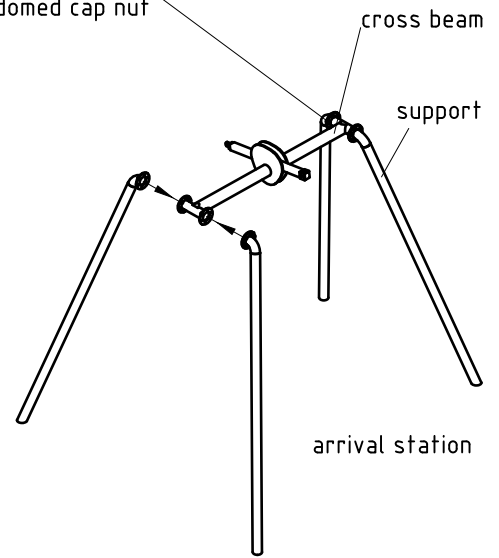

### Installation of ramp tubes

**4 x screw connection**  
 consisting of:  
 hexagon head bolt DIN 933-M16x40-zinc-coated;  
 washer DIN 125-17-zinc-coated;  
 prevailing torque type hexagon domed cap nut  
 DIN 986-M16-zinc-coated.

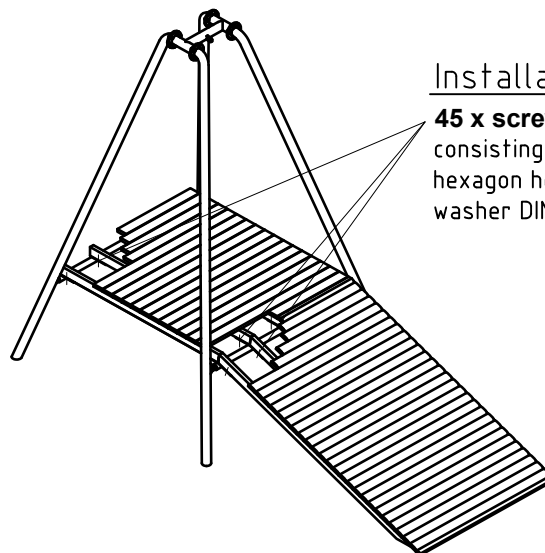

### Installation of wooden platform und ramp:

**45 x screw connection**  
 consisting of:  
 hexagon head wood screw DIN 571-10x80-A2.;  
 washer DIN 125-10,5-A2

cross beam of starting station

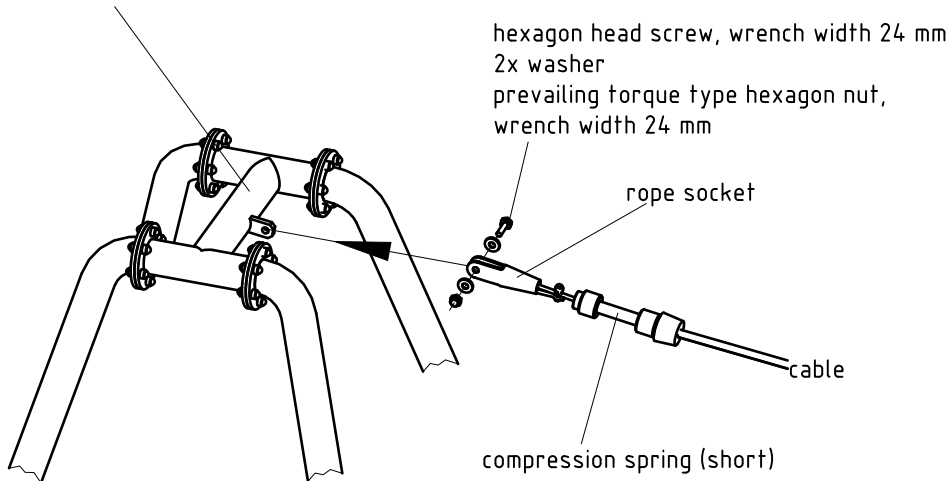

tensioning device

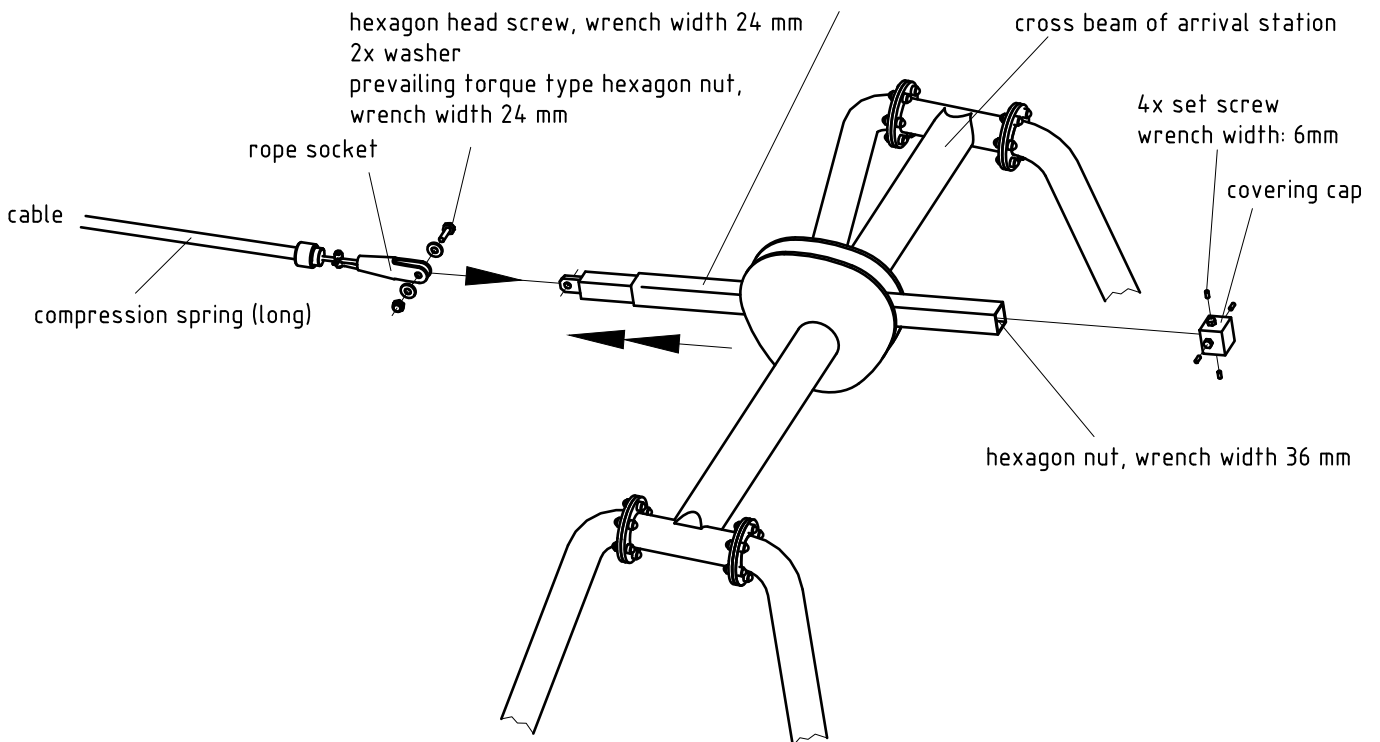

# Measurement on-site

for cable length determination

Please fill in this form and return it to:  
**Kaiser & Kühne Freizeitgeräte GmbH**  
Im Südloh 5  
27324 Eystrup  
Fax +49(0)4254 / 93 15 24

## Address for delivery of the cable

Order No. K&K: **B/**

Building project: ..... Location: .....

Installation enterprise:

1. →



2x 2x 1x

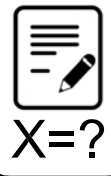

2. →

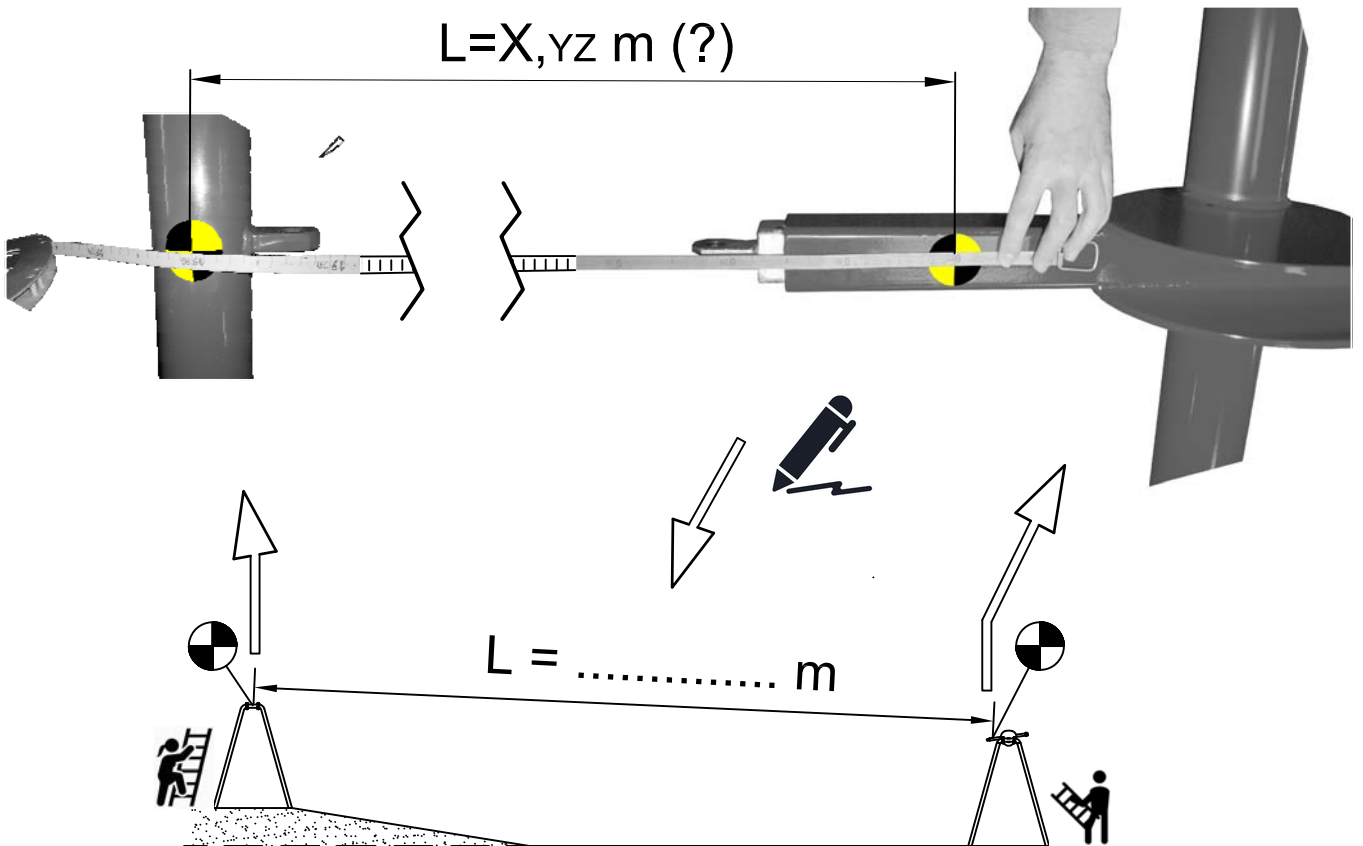

3. →



.....  
Date

.....  
Signature / Company stamp

**Einstellbarkeit bzw.  
Optimierung des  
Seilwagenlaufs**



**Adjustment resp.  
improvement of the pulley  
course on the rope**

Für einen sauberen Lauf des Wagens, und um Verkanten oder Verletzung des Seils auszuschließen, können die seitlichen Anschlagplatten am Seilwagen mittels der Langlöcher in der Höhe verstellt werden.  
(im Lieferumfang enthalten: Schraubendreher Torx TX30 mit Bohrung für Pin – K&K Art.-Nr. 3490080)



For a proper course of the pulley and to avoid tilting or abrasion of the rope, the lateral impact plates of the pulley can be vertically adjusted ( included in delivery: screw driver Torx TX 30 with drill for pin – K&K item-Nr. 3490080)





**Kontrollmaß zur Überprüfung  
bei jedem Wartungsintervall**

**Specification to be checked  
on each service interval**

Rundstab  $\varnothing$  8 mm darf nicht  
durch die Öffnung passen!



The 8 mm finger rod must  
not fit into the notch!

Abstand  $<$  7 mm: O.K.

Abstand  $\geq$  7 mm:  
AUSTAUSCH!!



Gap  $<$  7 mm: O.K.

Gap  $\geq$  7 mm:  
REPLACEMENT!!