

1. Assign a location for the equipment considering the space requirements (impact area).
2. Excavate soil for foundations of starting point and terminus, according to drawing (with level ground, provide additional formwork for the foundations of starting point and terminus).
Please note: To achieve maximum stability and safe installation, a moderate level of soil solubility is indispensable.
3. Due to the danger of overstraining the tube bends of the posts, we recommend to begin with mounting two posts to each crossbeam (see figure "Installation of supports"). Raise the unit by using an appropriate lifting gear and put assembly into foundation holes (respectively into formwork) after mounting the reinforcement cages. Support temporarily, in accordance with all security-relevant rules. Afterwards mount the remaining two posts as well as the reinforcement cages to the crossbeam.
4. Align starting point and terminus and grout foundations (according to drawing) with compressed concrete C20/25. Lift up reinforcement and ensure a concrete covering of at least 5 cm.
5. Mould a suitable hill course for starting point and terminus, according to drawing. The impact attenuating surface within the impact area (see ground view) shall at least conform to the minimum values for a critical fall height of 1000 mm (see EN 1176-4).
6. For wire cable forwarding, please complete attached form "Measurement on site" and return sheet to your distributor or to K&K Freizeitgeräte.

After setting of concrete foundations: (see figure "Installation of wire cable")

7. For cable assembly, the tensioning devices mounted to the crossbeam of the terminus must be relaxed as follows: remove protective caps from tensioning devices by loosening the set screws by an Allen key 6 mm across-flats.
Extend the tensioning devices to the stop by a spanner jaw size 36 mm.
8. Hang up cable with traveller: Remove hexagon head screw from cable socket (24 mm across-flats), match ends of cable socket with fixing hole at end of tensioning device, reinsert screw and fix it with a prevailing torque type nut.
Attention: Tighten the screw such that the cable socket barely remains flexible.
Perform that procedure both at the starting point and at the terminus.
9. Tension the cable equally at both ends such that the pendulum seat (with a load of 69,5 kg) keeps ground clearance of at least 0,35 m (according to EN 1176-4). If necessary, shorten length of seat chain above the handle. Do not fall below the minimum length of 1,80 m for chain including handle.
10. To make sure a proper course of the traveller on the cable, the lateral impact plates of the traveller are vertically adjustable to avoid tilting or abrasion of the cable.
11. Check all screw connections and cable tension according to maintenance instructions after 4-5 weeks and retighten, if necessary. Afterwards, cover the screw heads with protective caps (included in delivery).

Tools: lifting gear (for approx. 0,5 t)
ladder, spanner, Allen key

Minimum/maximum wire cable sag:

sag = vertical distance from

- imaginary line between cable suspension points (K&K: from centre to centre of wedge sockets) and
- centre of sagging wire cable measured at low point

Minimum sag: 38 cm (without load)

Maximum sag: 42 cm (without load)

maximum gradient permitted:

$\Delta h = 1,30$ m

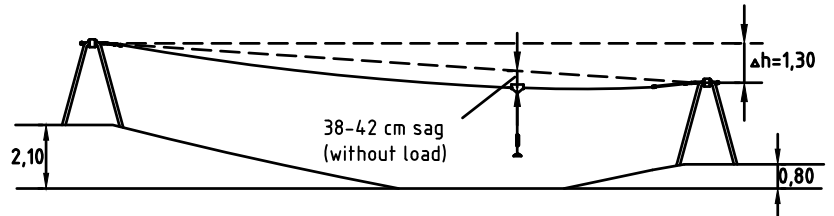

Impact area:

(area marked by dashed line, see ground view)

area = 166 m²

free height of fall = 1,00 m

Instruction on (re-)adjusting the wire cable:

1. Remove protective cap from tensioning device by loosening four set screws by means of an Allen key 6 mm across-flats.
2. Turn hexagon nut by means of a spanner jaw size 36 mm, direction corresponding to intended effect.

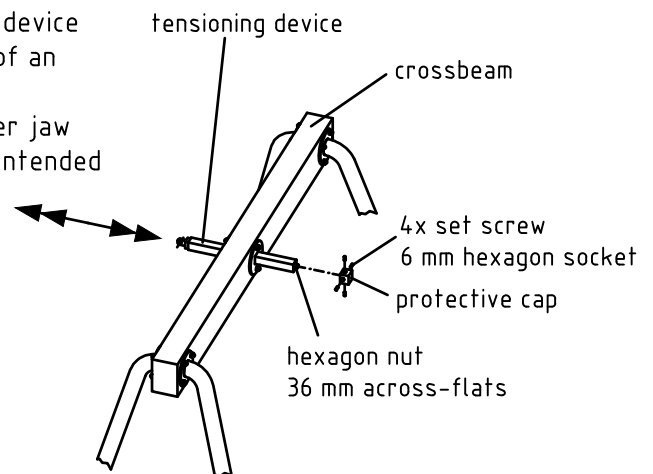

Please take care that all special tools (e.g. special Allen key for secured Allen screws etc.) and all specific documents which are or may be useful for safety management acc. to EN 1176-7 (e.g. invoice, delivery note, order acknowledgement, installation instructions, maintenance instructions) are forwarded to the responsible persons.

Cross-section / hills

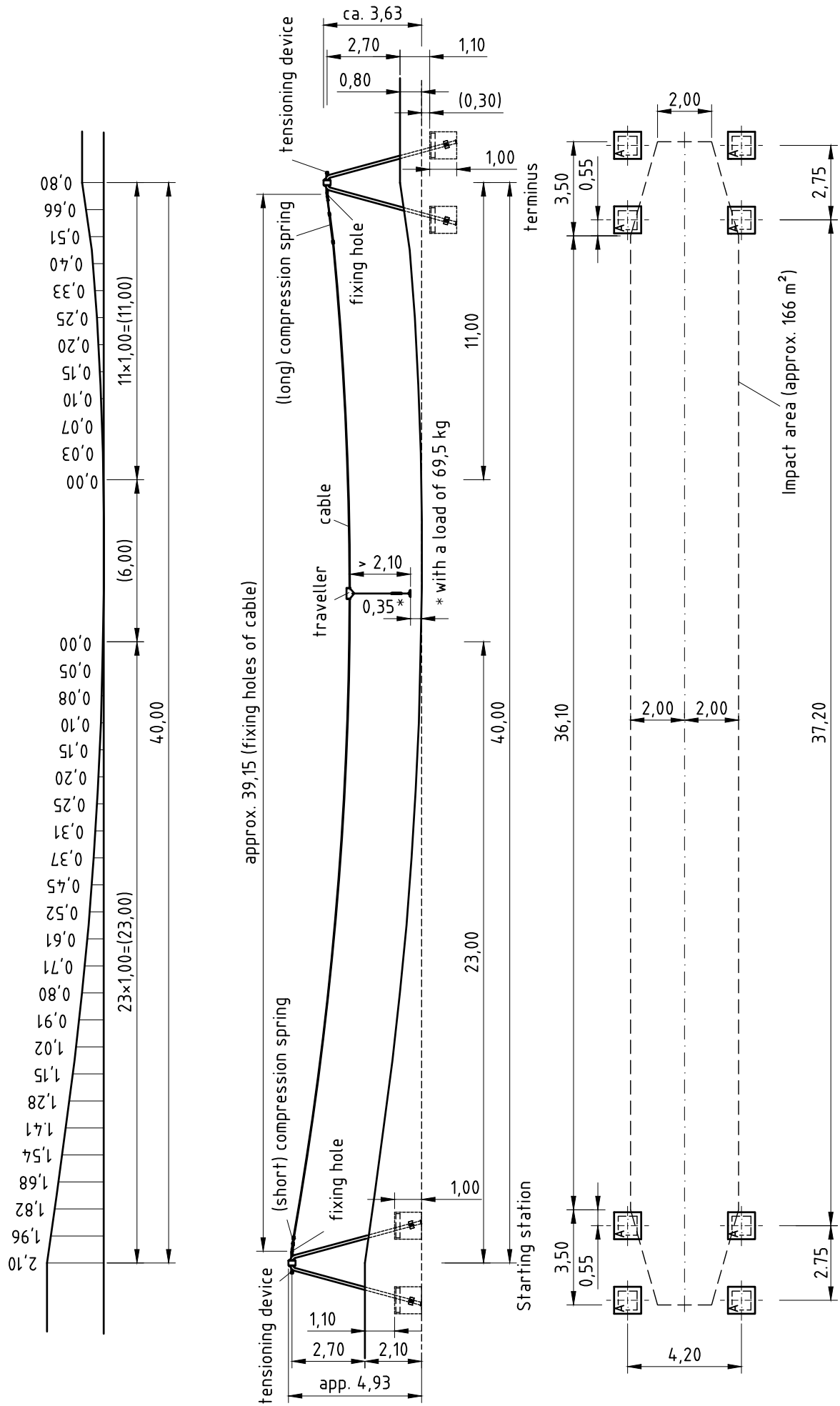

Installation

Item No.
0-42240-000
0-42241-000

Description
K&K Cableway (40,00)

Scale
1:200

Date
05/18 DW

Page
3

Foundation type A

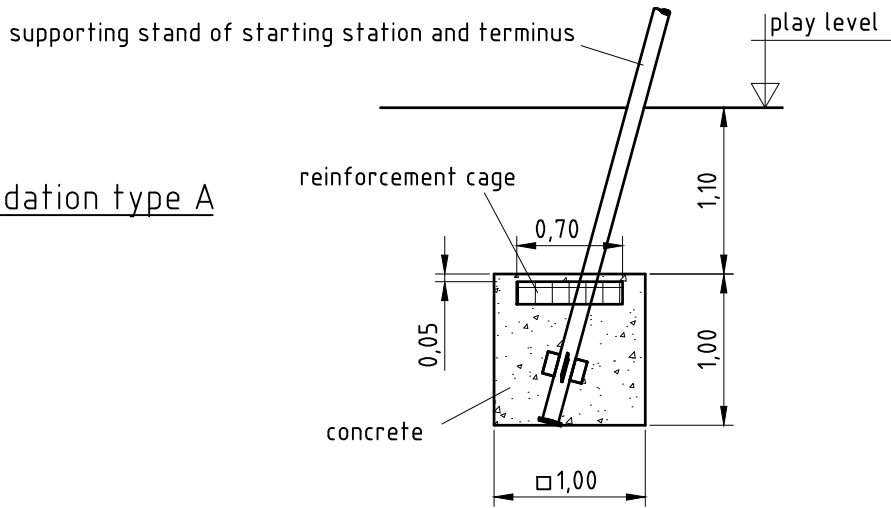

Installation of supports:

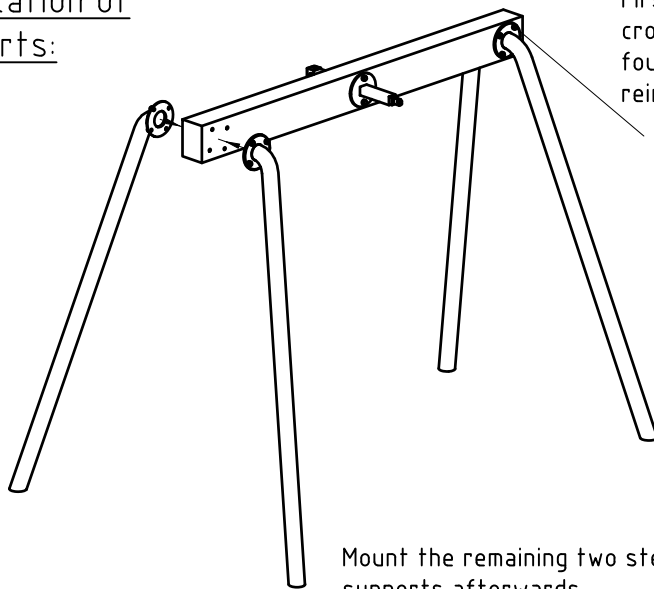

First mount two steel supports to each crossbeam, raise and put unit into foundation holes together with placing reinforcement cages.

4 x screw connection

- consisting of:
 hexagon head screw DIN 931-M16x230-zinc-coated;
 2x washer DIN 125-18-zinc-coated;
 prevailing torque type hexagon domed cap nut DIN 986-M16-zinc-coated;
 2x grey protective cap SKS 16

Mount the remaining two steel supports afterwards.

Installation of wire cable

Uncoil cable free of twists!

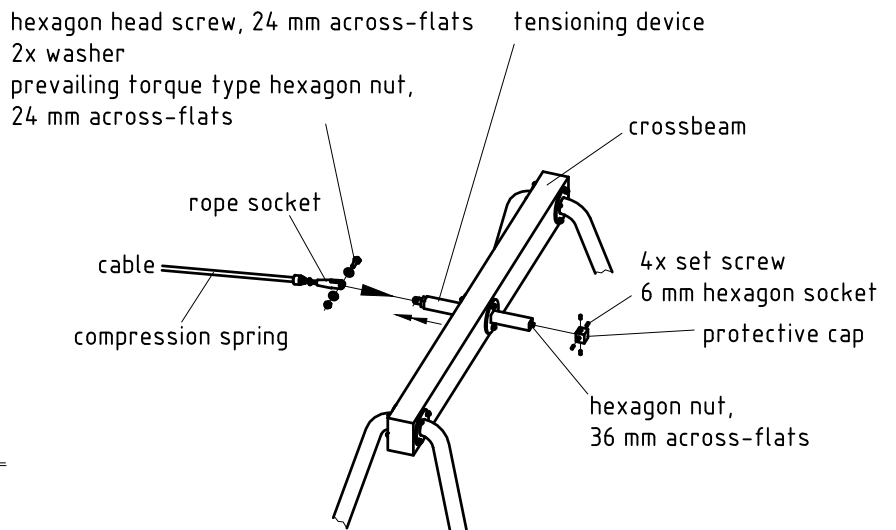
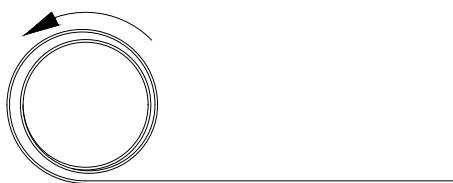

Measurement on-site

for cable length determination

Please fill in this form and return it to:
Kaiser & Kühne Freizeitgeräte GmbH
Im Südloh 5
27324 Eystrup
Fax +49(0)4254 / 93 15 24

Address for delivery of the cable

Order No. K&K: **B/**

Building project: Location:

Installation enterprise:

1. →



2x 2x 1x

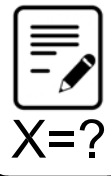

2. →

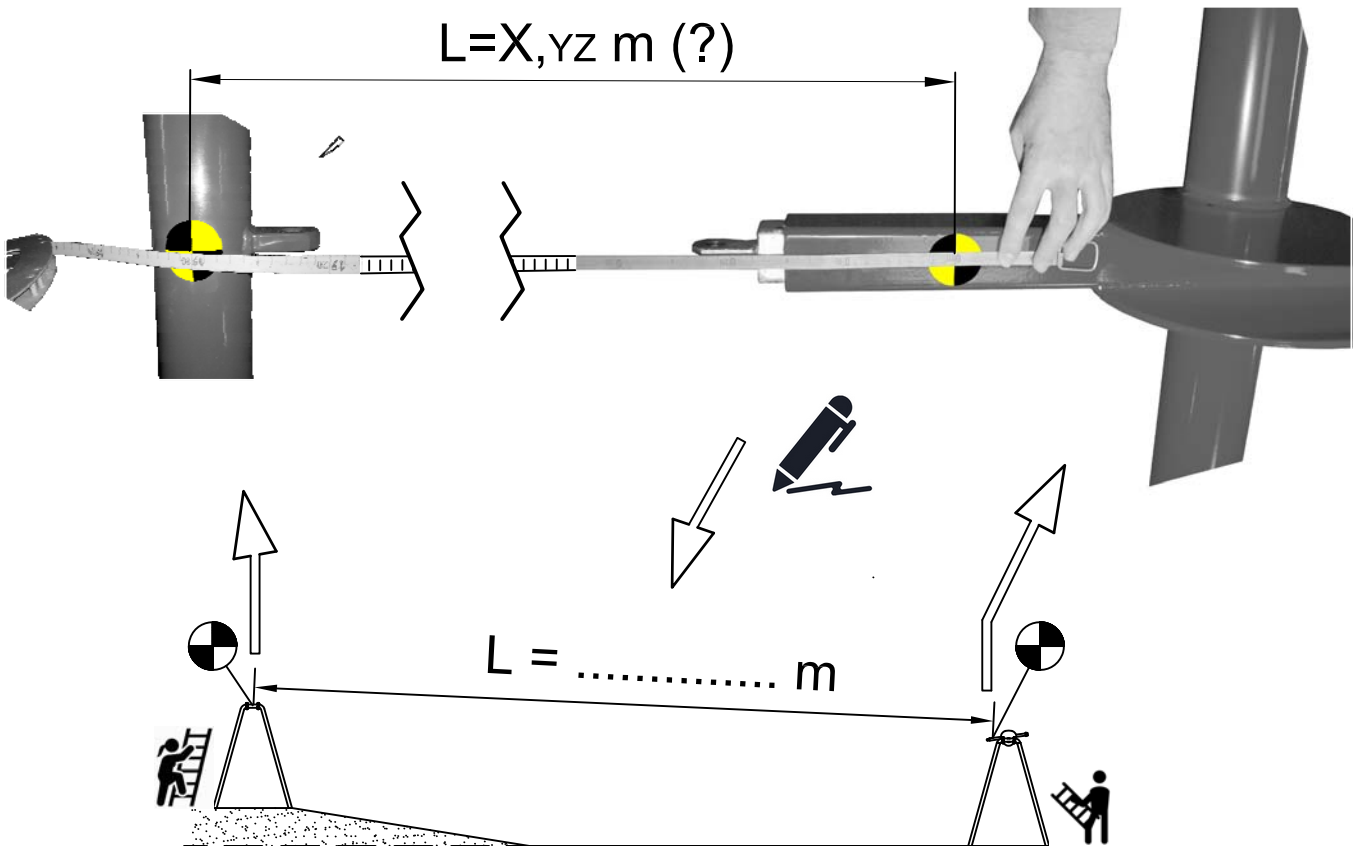

3. →



.....
Date

.....
Signature / Company stamp

**Einstellbarkeit bzw.
Optimierung des
Seilwagenlaufs**



**Adjustment resp.
improvement of the pulley
course on the rope**

Für einen sauberen Lauf des Wagens, und um Verkanten oder Verletzung des Seils auszuschließen, können die seitlichen Anschlagplatten am Seilwagen mittels der Langlöcher in der Höhe verstellt werden.
(im Lieferumfang enthalten: Schraubendreher Torx TX30 mit Bohrung für Pin – K&K Art.-Nr. 3490080)



For a proper course of the pulley and to avoid tilting or abrasion of the rope, the lateral impact plates of the pulley can be vertically adjusted (included in delivery: screw driver Torx TX 30 with drill for pin – K&K item-Nr. 3490080)



**Kontrollmaß zur Überprüfung
bei jedem Wartungsintervall**

**Specification to be checked
on each service interval**

Rundstab \varnothing 8 mm darf nicht
durch die Öffnung passen!

The 8 mm finger rod must
not fit into the notch!



Abstand < 7 mm: O.K.

Gap < 7 mm: O.K.

Abstand \geq 7 mm:
AUSTAUSCH!!

Gap \geq 7 mm:
REPLACEMENT!!

