

1. Assign a device location considering the space requirement (impact area). Slide direction recommended: north-east or in half-shade of trees.
2. Excavate soil for foundations, according to drawing.
Please note: To achieve maximum stability and a safe installation, a moderate level of soil solubility is required.
3. Pour in a drain layer of gravel of approx. 10 cm thickness between the bottom of the posts and plain base of foundation.
4. Insert reinforcing steel into the corresponding holes of the posts.
5. Place posts type A according to the corresponding number (see foundation layout) into the respective foundation hole. Play level mark (=aluminium blind rivet) complies with the installation depth. Align every post by means of the play level mark facing into the same direction (see detail or foundation layout).

6. For installation of the pre-assembled components and/or single parts, the screws slightly have to be lubricated with installation paste!

Screw together platform and posts by using the middle hole in the mounting brackets.

Tighten all screws after having aligned all components.

Install the slide exit with an inclination of 5° in sliding direction so that rain water can drain off.

Screw connections see details in attached list.

We recommend not to insert the protection caps enclosed before first maintenance as they are only suitable for one-time use (see description below).

7. Grout foundations with compressed concrete C20/25, chamfer and round off the edges, cover the foundations with a surface which meets the requirement for impact attenuation so that its critical fall height is equal to or greater than the maximum free height of fall of the equipment (acc. to EN 1176-1). The run-out section fall zone must have surfacing with a critical fall height of at least 1000 mm (acc. to EN 1176-3).
8. Release for play after concrete foundations have set.
9. According to maintenance instructions, check all screw connections after 4-5 weeks and retighten, if necessary. Afterwards cover the screw heads with protection caps as follows: Insert grey protection caps into the countersunk drills (e.g. for platforms). The non-countersunk drills (e.g. for railings or a slide) have to be covered with the red protection caps by placing them onto the base part. Strongly pound them (e.g. by using a plastic mallet) until they audibly snap into the base part groove.

Please ensure that all special tools supplied (e.g. Allen key for secured Allen screws etc.) and all specific documents which are or may be useful for safety management acc. to EN 1176-7 (e.g. invoice, delivery note, order acknowledgement, installation instructions, maintenance instructions) are forwarded to the persons responsible.

Necessarily insert all attachment parts before tightening the screws. It is NOT possible to insert them afterwards.

platform orientation
1:100

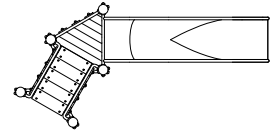

detail of check mark
1:5

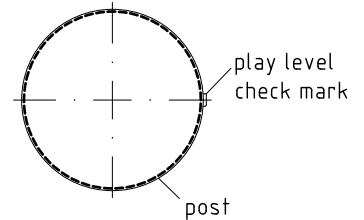

platform fastening
1:10

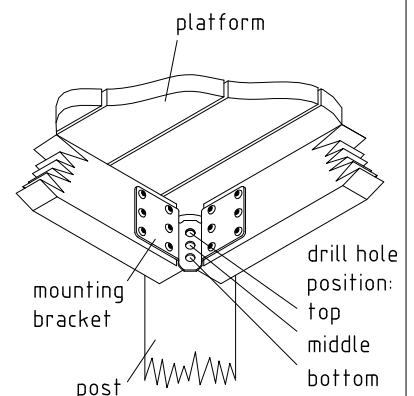

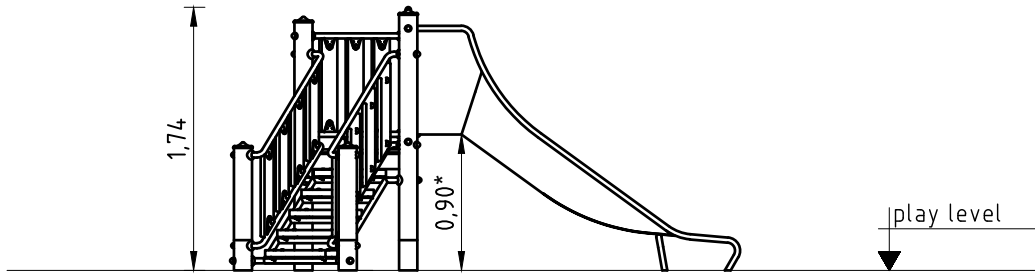

maximum free height of fall

- hatched area:
- free from obstacles
 - without requirement for shock-absorbing properties

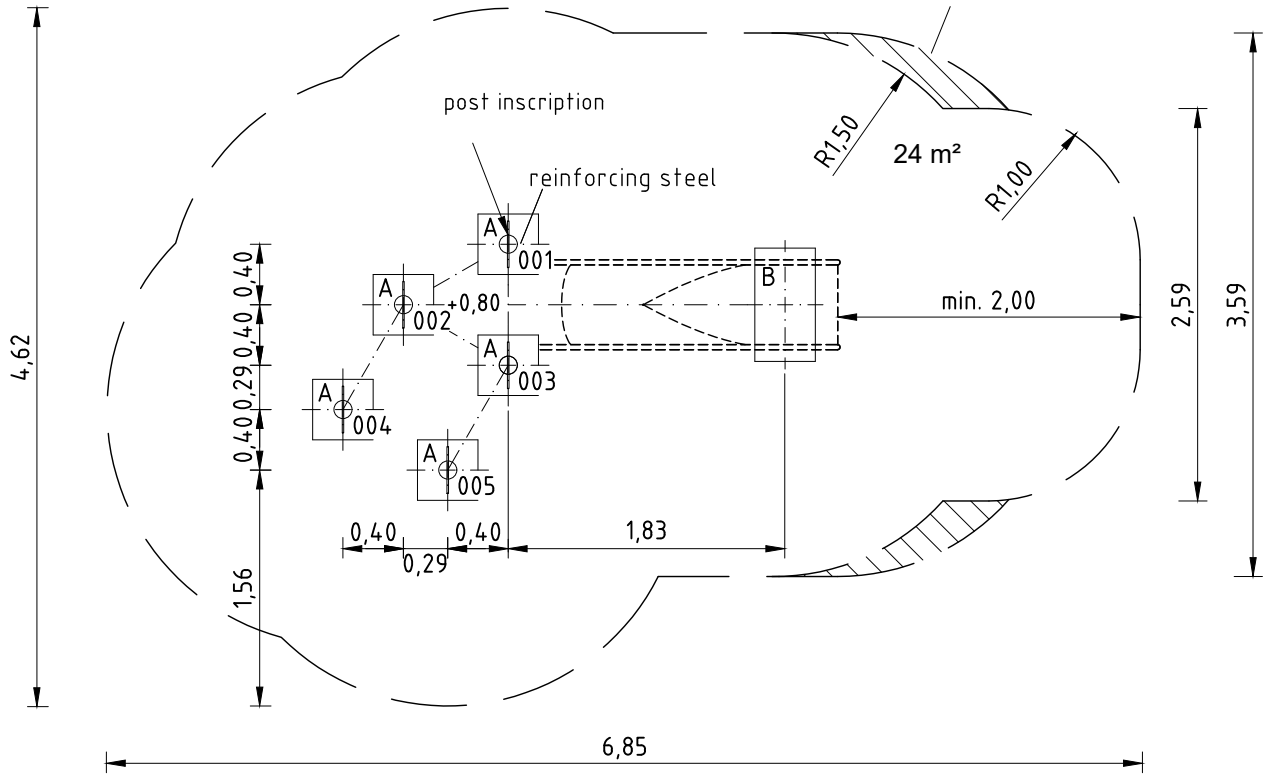

type A (5x)
1:20

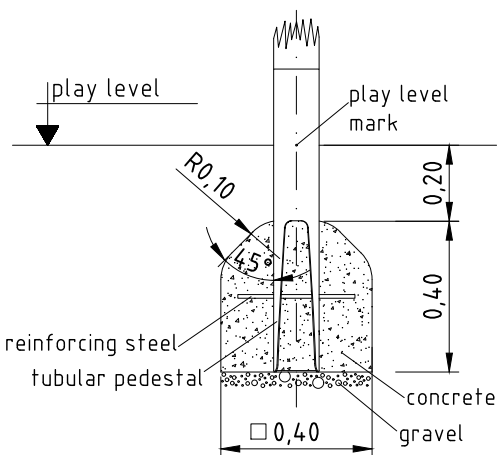

type B (1x)
1:20

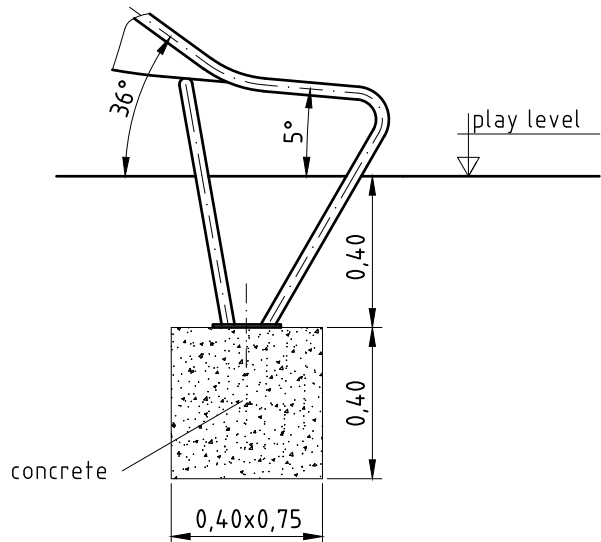

Item: **041140700**
Combi slide (0,80)

Order:

1299090

Location:

Building Project:

3 x SFRS1200001 Platform at Robinia post, nut is platform-sided

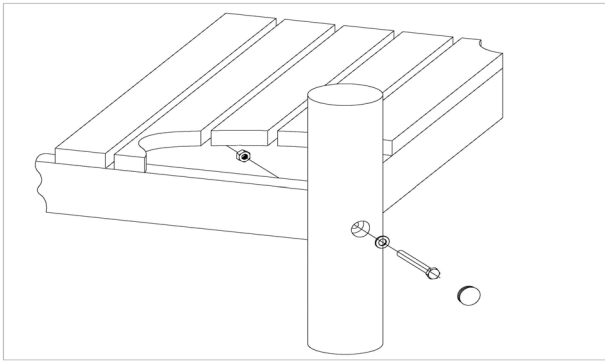

per SC	Total	K&K-Item	Marking
1 x	3 x	3430129	Washer Ø 14 DIN1440 A2
1 x	3 x	3430021	Lock nut M12 DIN985 A2
1 x	3 x	3300016	Grey domed plastic cover cap SL 36 G
1 x	3 x	3400700	Hexagon head screw M12 x 120 DIN931 A2 with screw security coating/FGB red

20 x SFRS1210001 Standard bolting of barriers, handrails, slides to Robinia posts

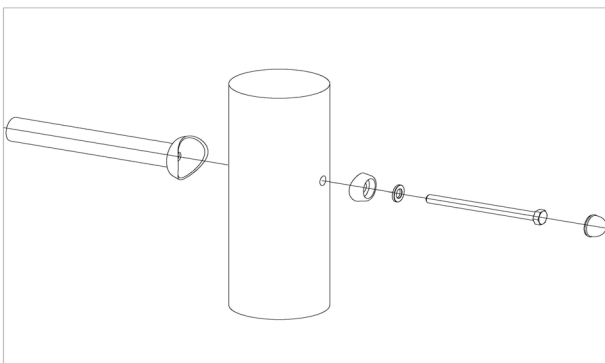

per SC	Total	K&K-Item	Marking
1 x	20 x	3300054	Red protective screw cap - lower part, domed M12
1 x	20 x	3300055	Red protective screw cap - upper part, domed M12
1 x	20 x	3430025	Washer Ø 13 DIN125 A2
1 x	20 x	3400702	Hexagon head cap screw M12 x 160 DIN931 A2 with screw security coating FGB red

1 x SFXS1070006 Slide run-out section (up to 2,00 m) on foundation stone bolt assembly

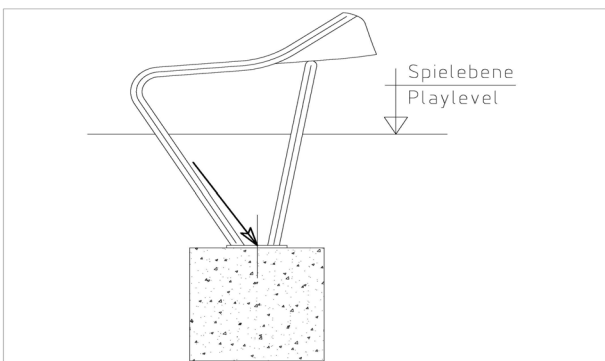

per SC	Total	K&K-Item	Marking
2 x	2 x	1070365	Set of stone bolts for slide run-out section M12x160

5 x SFES1270007 Reinforcing steel for tubular pedestals

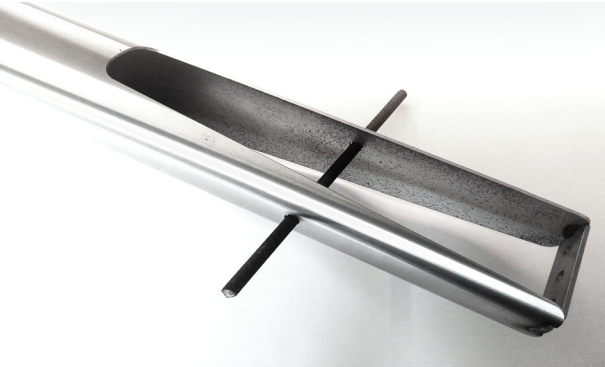

per SC	Total	K&K-Item	Marking
1 x	5 x	2130000	Reinforcing steel Ø 10 x 310 DIN 488

Item: **041140700**
Combi slide (0,80)

Order:

1299090

Location:

Building Project:

1 x SFWZ0000013 Lubricating metal, twin bag (2 x 4 g)



per SC	Total	K&K-Item	Marking
2 x	2 x	5300024	Metaflux fitting lubricant 2x4 g