

Cheese-head screw
DIN 912/ISO 4762-M8x20-A2

4x Screw connection
Hexagon head bolt DIN 933-M16x55-A2;
2x Washer DIN 125-2-17-A2; prevailing
torque type hexagon nut DIN
986-M16-A2;

8x Screw connection
Hexagon head bolt DIN 933-M16x45-A2;
2x Washer DIN 125-2-17-A2; prevailing
torque type hexagon nut DIN
986-M16-A2;

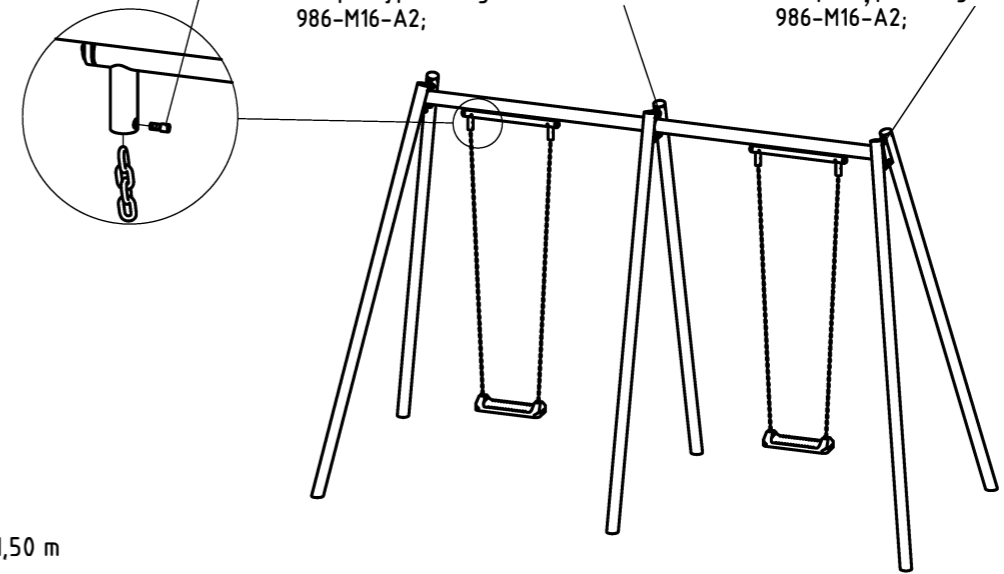

Free height of fall = 1,50 m

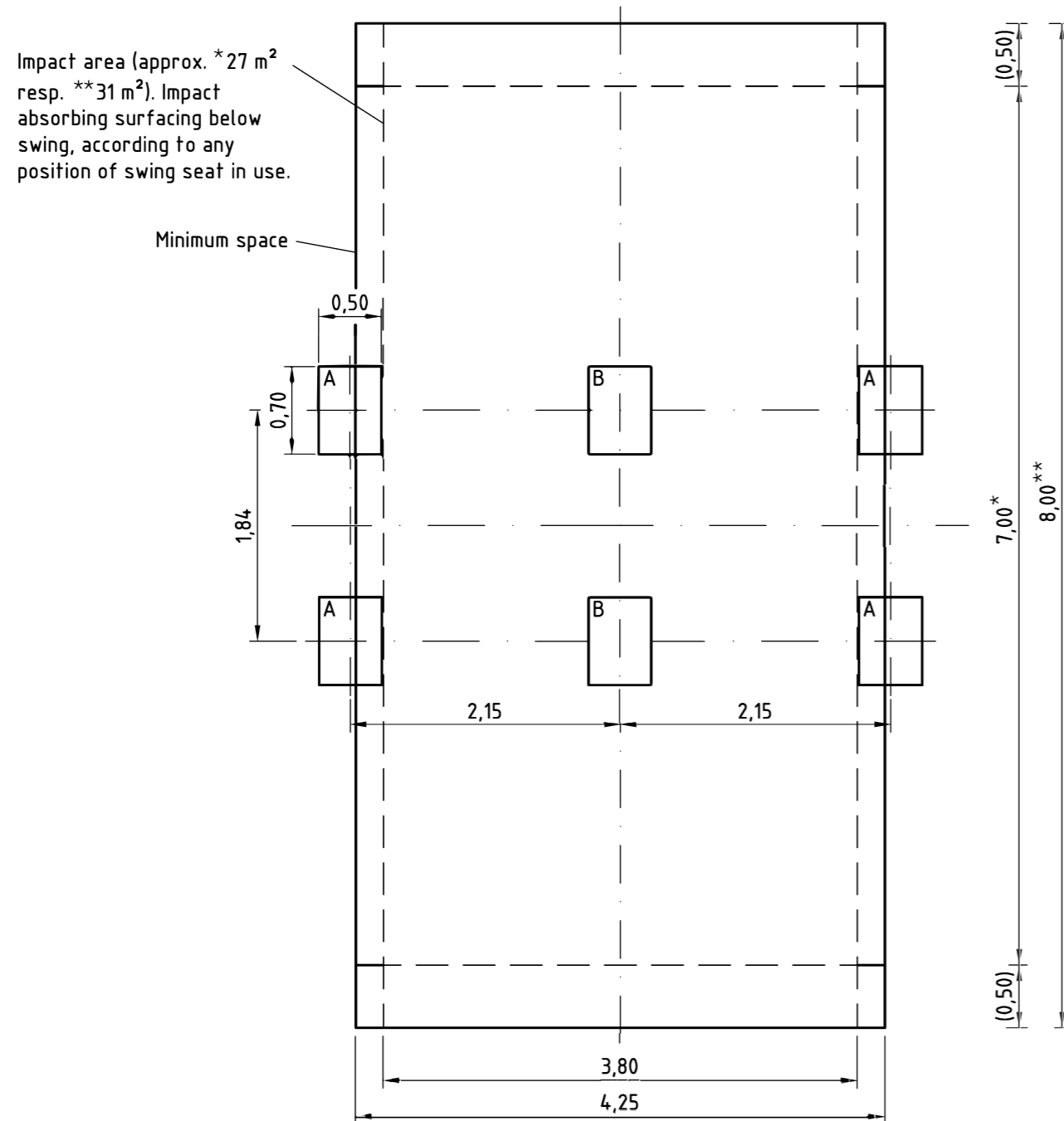

Foundation:
Type A
1:20

Foundation:
Type B
1:20

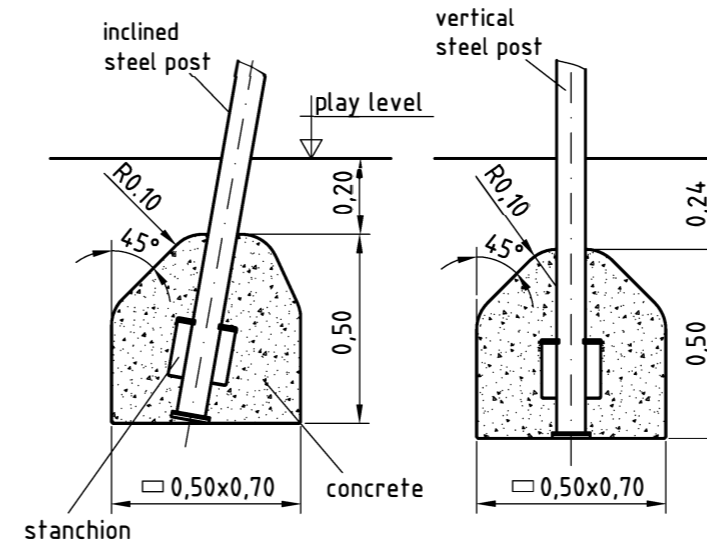

1. Assign location of equipment considering the minimum space requirements (falling space).
2. Excavate soil for foundations, according to drawing. Please note: To achieve maximum stability and a safe installation, a moderate level of soil solubility is required.
3. **Attention: For installation of the posts at swing crossbeam, the screws have to be lubricated thinly with installation paste!**
4. Mount steel posts at cross beam according to drawing, put assembled equipment into foundation holes and align it.
5. Grout foundations with compressed concrete C20/25, chamfer and round off the edges and cover with a surface which shall meet the requirements for impact attenuation so that the critical fall height of the surfacing shall be equal to, or greater than, the free height of fall of the equipment (acc. to EN 1176-1).
6. Attach chains to chain adapter in swing axle after concrete foundations have set: Unscrew cheese head screw (M8x20) inside adapter, insert last chain link and fix with screw. Attention: For installation, the cheese head screw has to be lubricated thinly with installation paste! Please note that the cheese-head screw has to be tightened e.g. with Allen key or catch stoutly without overwinding the screw. If necessary, cut length of chain in order to ensure minimum ground clearance of 0,45m below swing seat.
7. Check all screw connections according to maintenance instructions after 4-5 weeks and retighten, if necessary.

Please take care that all special tools (e.g. special Allen key for secured Allen screws etc.) and all specific documents which are or may be useful for safety management acc. to EN 1176-7 (e.g. invoice, delivery note, order acknowledgement, installation instructions, maintenance instructions) are forwarded to the responsible persons.

*)Measure in case of surfacing with impact absorbing effect that is level with the surrounding area (cf. EN 1176-2 4.10.2.1). Towards swing direction there shall be an additional area of 0,50m length free from obstacles.

**)Measure in case of natural surfacing with impact absorbing effect (cf. EN 1176-2 4.10.2.1)

<p>© 2013 Kaiser & Kühne Freizeitgeräte GmbH D-27324 Eyrstrup Telefon 04254 / 93150 Telefax 04254 / 931524</p>	Date/Name Gez. 26.10.11 KL	Article 940340020
	Geänd. 11.04.13 EB	Description K&K Swing combination (2,50)
	Scale 1:50 / A3	Drawing Installation