

cutaway drawing of the trough to be moulded on site (after founding the device)
1:20

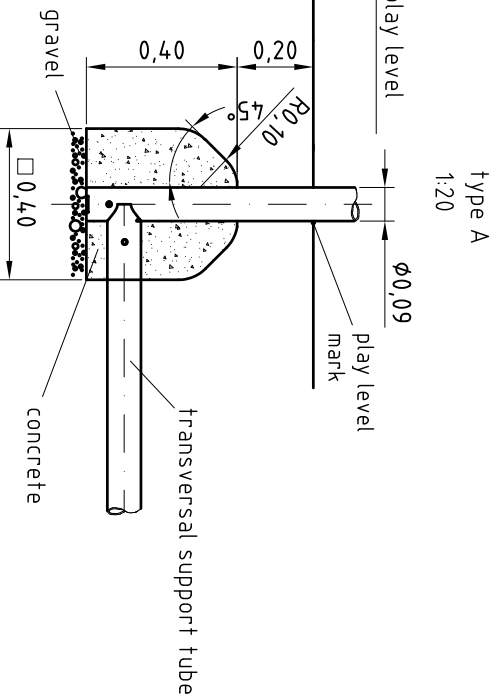

Exemplary illustration

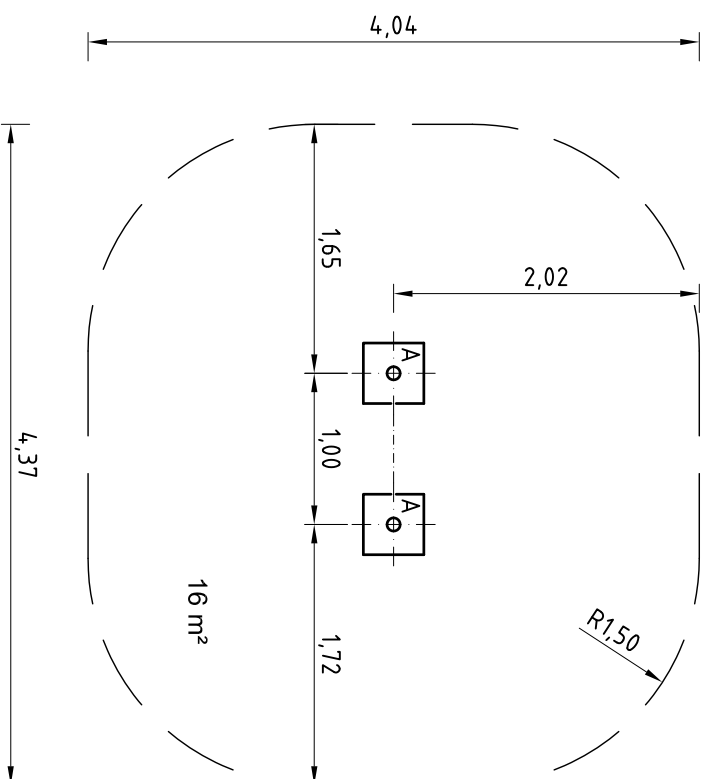
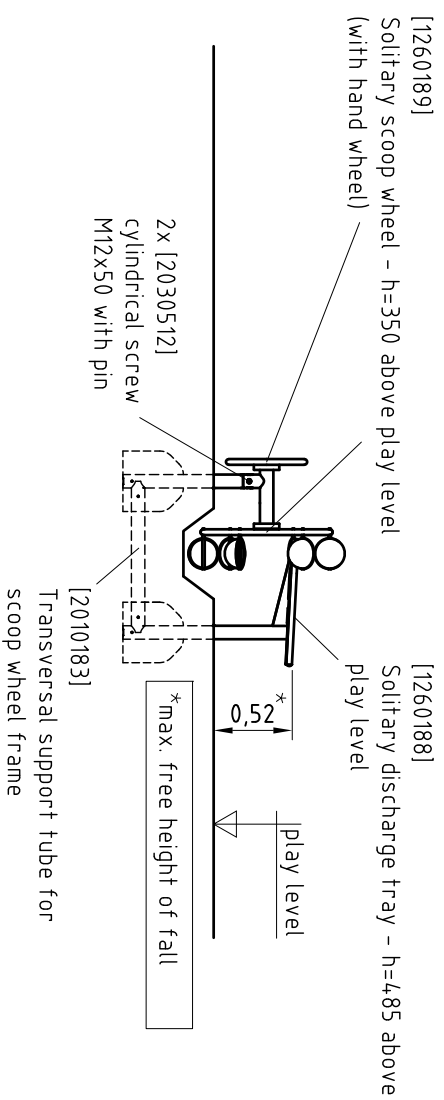
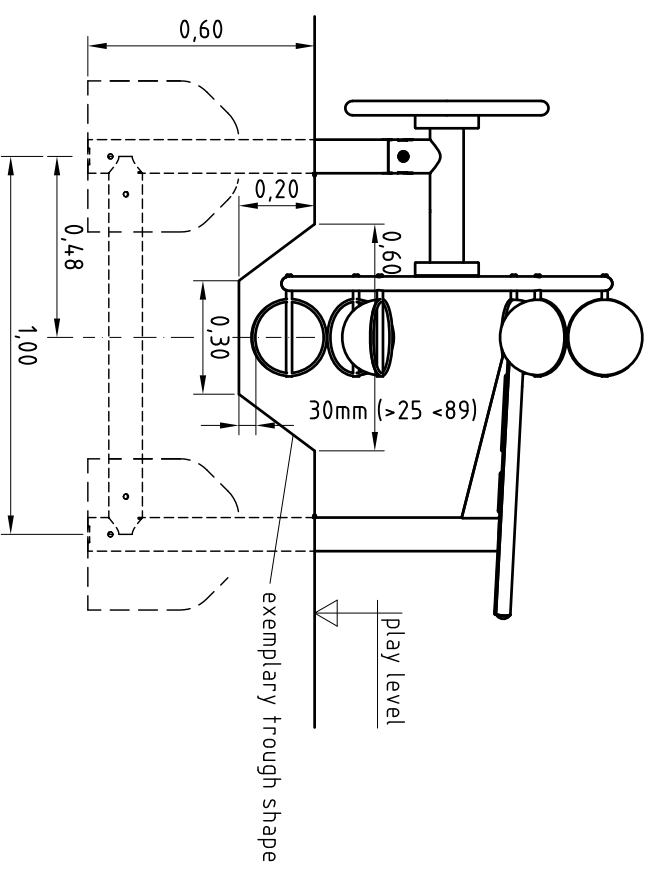
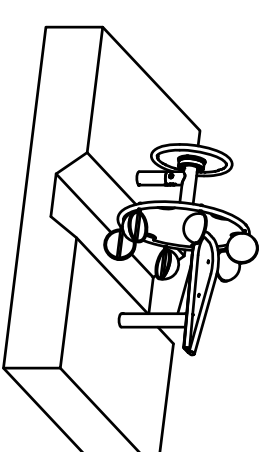

top view
1:5

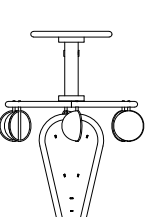



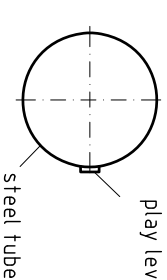

play level mark
1:5



1. Assign a location for the equipment considering the space requirements/impact area.
2. Excavate soil for foundations, according to drawing.
Please note: To achieve maximum stability and a safe installation, a moderate level of soil solubility is indispensable.
3. Pour in a layer of gravel of approx. 10 cm thickness between the bottom of the steel tubes and plain base of foundation.
4. **For installation of the pre-assembled components and/or single parts, the screws slightly have to be lubricated with installation paste! Tighten all screws after having aligned all components.**
Insert the transversal support tube into both vertical posts (similar to a bayonet connection). Fasten welded unit of scoop wheel and hand wheel to the corresponding post by means of two cylindrical screws M12x50 with pin. Mind the discharge tray is welded to its support post.
5. Place the entire unit into the foundation holes and align it: Play level mark (= welding pin) conforms to the mounting depth of the tubes.
7. Grout foundations with compressed concrete C20/25, chamfer and round off the edges, cover the foundations with a surface which meets the requirements for impact attenuation so that the critical fall height of the surfacing is equal to, or greater than, the free height of fall of the equipment (acc. to EN 1176-1).
8. Mould trough respectively water way according to the specifications stated in the cutaway drawing. The dimensions must correspond to the safety requirements determined in European standard for playground equipment EN 1176-1 concerning entrapment.
9. Release for play after concrete foundations have set.
10. Check all screw connections acc. to maintenance instructions after 4-5 weeks and retighten, if necessary.

Please take care that all special tools (e.g. special Allen key for secured Allen screws etc.) and all specific documents which are or may be useful for safety management acc. to EN 1176-7 (e.g. invoice, delivery note, order acknowledgement, installation instructions, maintenance instructions) are forwarded to the persons responsible.

 <p>Kaiser & Kühne Freizeitgeräte GmbH D-27324 Eysstrup T +49 4254 / 93 15 0 F +49 4254 / 93 15 24</p>	Datum/Name	Artikel
	<p>Gez. 06.03.2014 EB Geänd. 04.11.2020 EB</p>	<p>0-33240-002A</p>
Masstab	Benennung	
1:50 / A3	Scoop wheel	
	Zeichnung	
	Installation	
	<p>EN 1176</p>	

<u>Parts list</u>		033240002A	GB
item no.	quantity	description	image
1260188	1	Solitary water discharge tray h=485 above play level	
1260189	1	Solitary scoop wheel h=350 above play level	
2010183	1	Transversal support tube for scoop wheel frame	
2030512	2	Cylindrical head screw M12x50 with pin	
5300024	1	Metaflux fitting lubricant 2x4 g	