

Spatial view

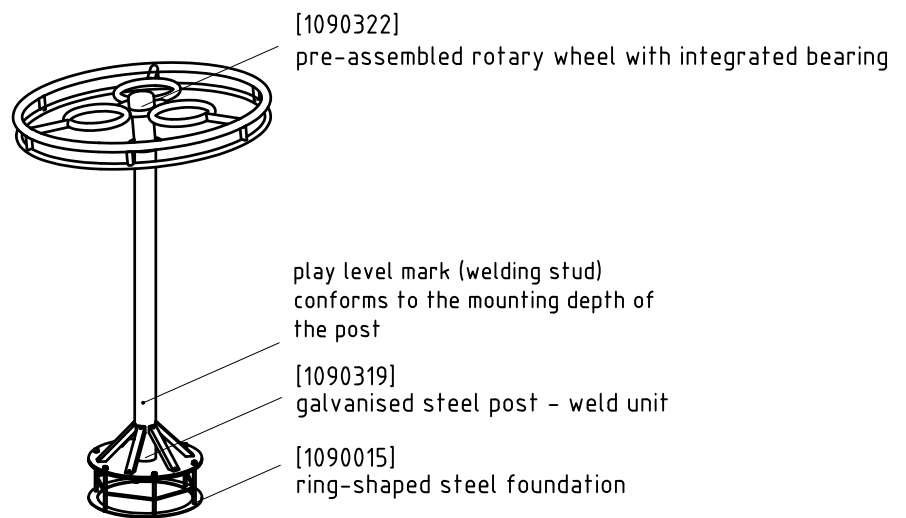

Installation instructions

1. Assign a location for the equipment considering the impact area (free/falling space).
2. Excavate soil for foundation, according to drawing.
Please note: To achieve maximum stability and a safe installation, a moderate level of soil solubility is required.
3. Grout foundation with compressed concrete C20/25, insert ring-shaped steel foundation into concrete, install it **on a level with top edge of foundation** (see detail) and align it with a spirit level.
4. After concrete foundation has set, fasten the bottom flange of the post to the upper ring of the foundation anchorage: flange - washer - prevailing torque type lock nut M16 (parts fixed to anchorage). Play level mark (welding stud) complies with the installation depth.
5. Fasten the pre-assembled rotary wheel to the upper flange of the steel post (see detail).
6. Due to forced movement, it is essential to cover the impact area with shock-absorbing surfacing material which meets the requirements for a critical fall height of at least 1000 mm (acc. to EN 1176-5).
7. Check all screw connections according to maintenance instructions after 4-5 weeks and retighten, if necessary.

Please ensure that all special tools (e.g. Allen key for secured Allen screws etc.) and all specific documents which are or may be useful for safety management acc. to EN 1176-7 (e.g. invoice, delivery note, order acknowledgement, installation instructions, maintenance instructions) are forwarded to the persons responsible.

Front view

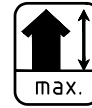

dimension mark -
total height of the equipment

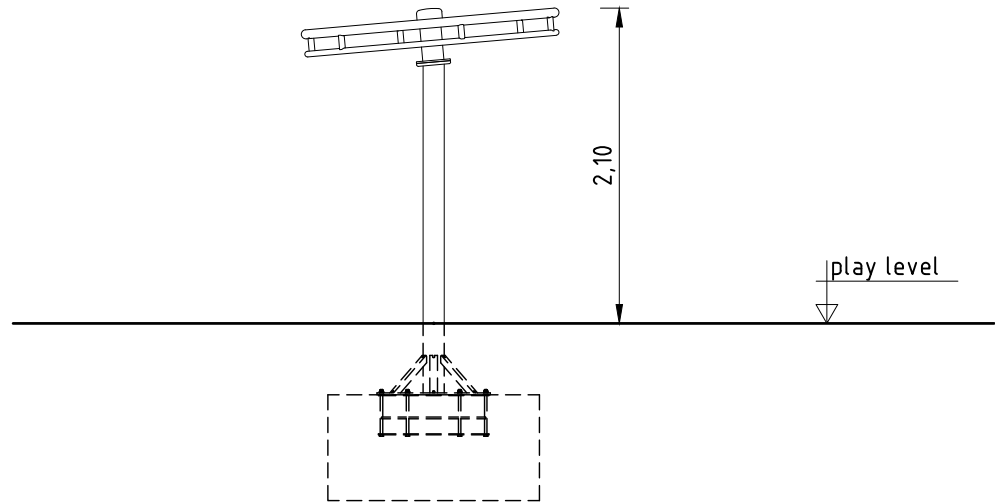

maximum free height of fall: 0,15 m

Top view & impact area

1:100
minimum space = 47 m²
(including 1 m free from obstacles,
surrounding the fall zone)

impact area 25 m²
(shock-absorbing surfacing mandatory)

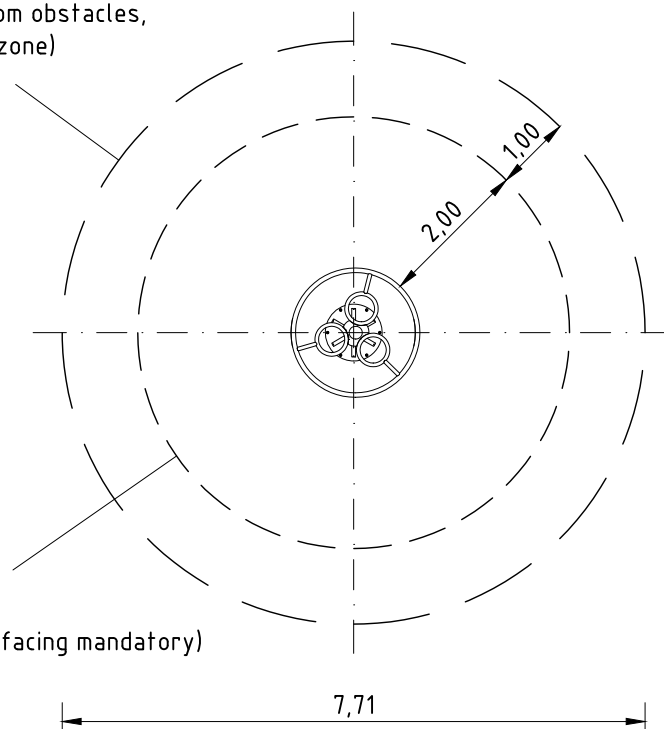

Installation detail

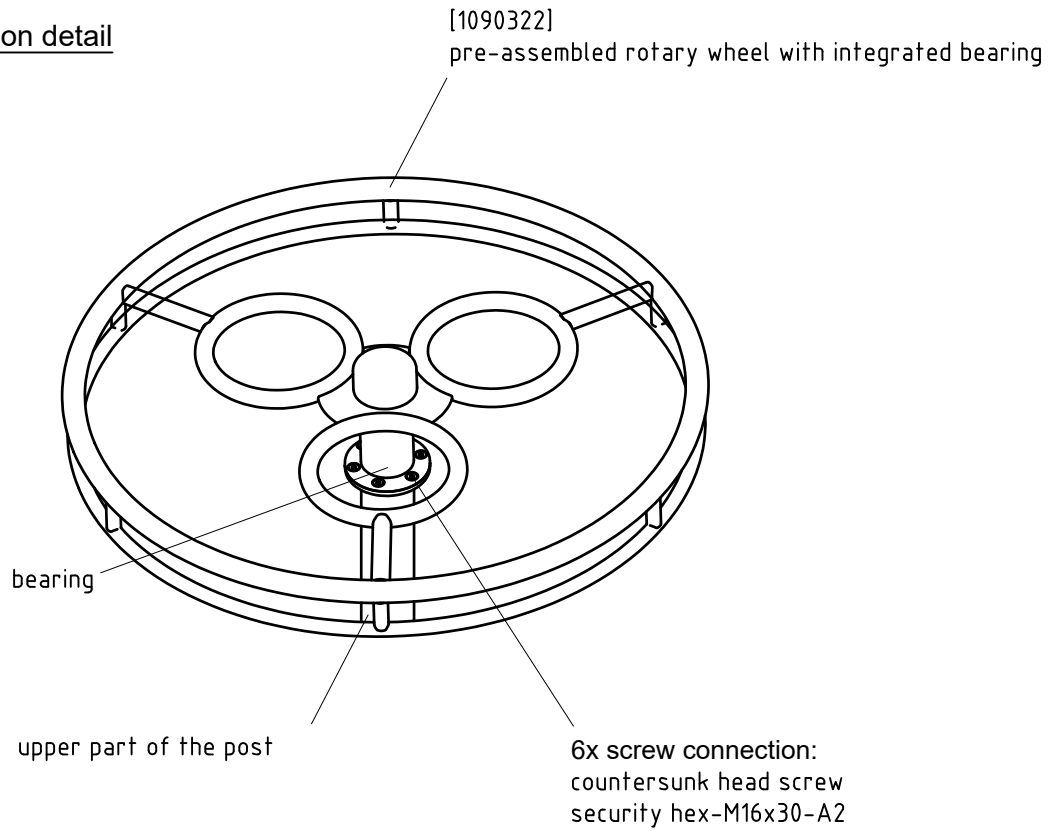

Foundation details

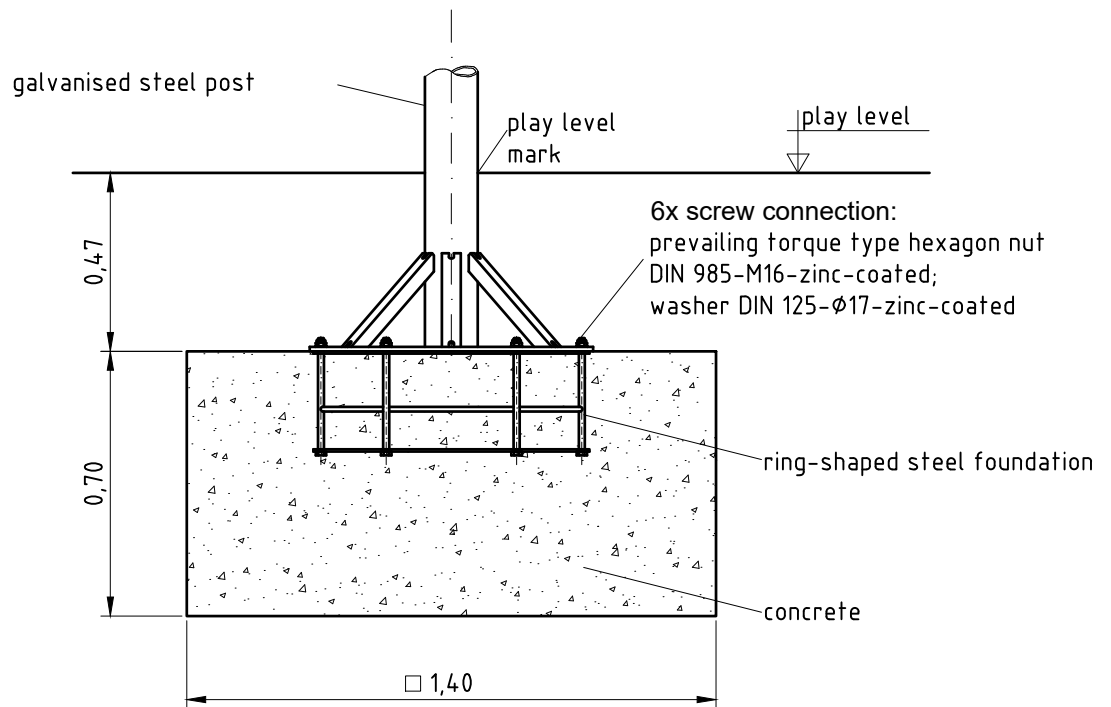

foundation (on site)
1x 1,40 x 1,40 x 0,70 m

(approximate) concrete needs
1,4 m³