

1. Assign a device location considering the space requirement (impact area).
2. Excavate soil for foundations, according to drawing.
Please note: To achieve maximum stability and a safe installation, a moderate level of soil solubility is required.
3. Pour in a drain layer of gravel of approx. 10 cm thickness between the bottom of the tubular pedestals and plain base of foundation.
4. Place posts type A (see foundation layout) according to the corresponding number into the respective foundation hole. Play level mark (=aluminium blind rivet) complies with the installation depth. Align every post by means of the play level mark facing into the same direction (see detail or foundation layout).
5. **For installation of the pre-assembled components and/or single parts, the screws slightly have to be lubricated with installation paste!**
Tighten all screws after having aligned all components.
Screw connections see details in list of screw cases attached.
6. Grout foundations with compressed concrete C20/25, chamfer and round off the edges, cover the foundations with a surface which meets the requirements for impact attenuation so that the critical fall height of the surfacing is equal to, or greater than, the free height of fall of the equipment (acc. to DIN EN 1176-1).
7. Release for play after concrete foundations have set.
9. According to maintenance instructions, check all screw connections after 4-5 weeks and retighten, if necessary. Afterwards cover the screw heads with protection caps.

Please ensure that all special tools supplied (e.g. Allen key for secured Allen screws etc.) and all specific documents which are or may be useful for safety management acc. to DIN EN 1176-7 (e.g. invoice, delivery note, order acknowledgement, installation instructions, maintenance instructions) are forwarded to the persons responsible.

Necessarily insert all attachment parts before tightening the screws.
It is NOT possible to insert them afterwards.

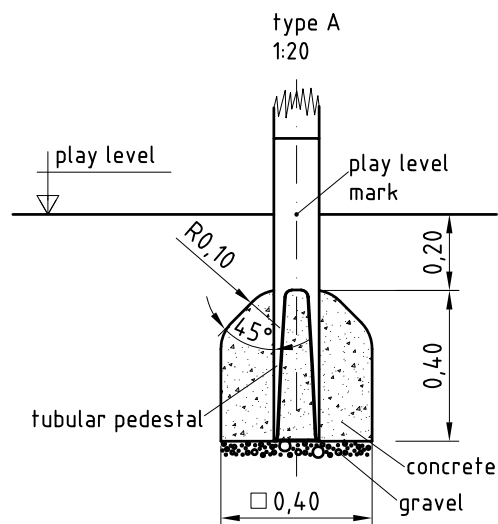
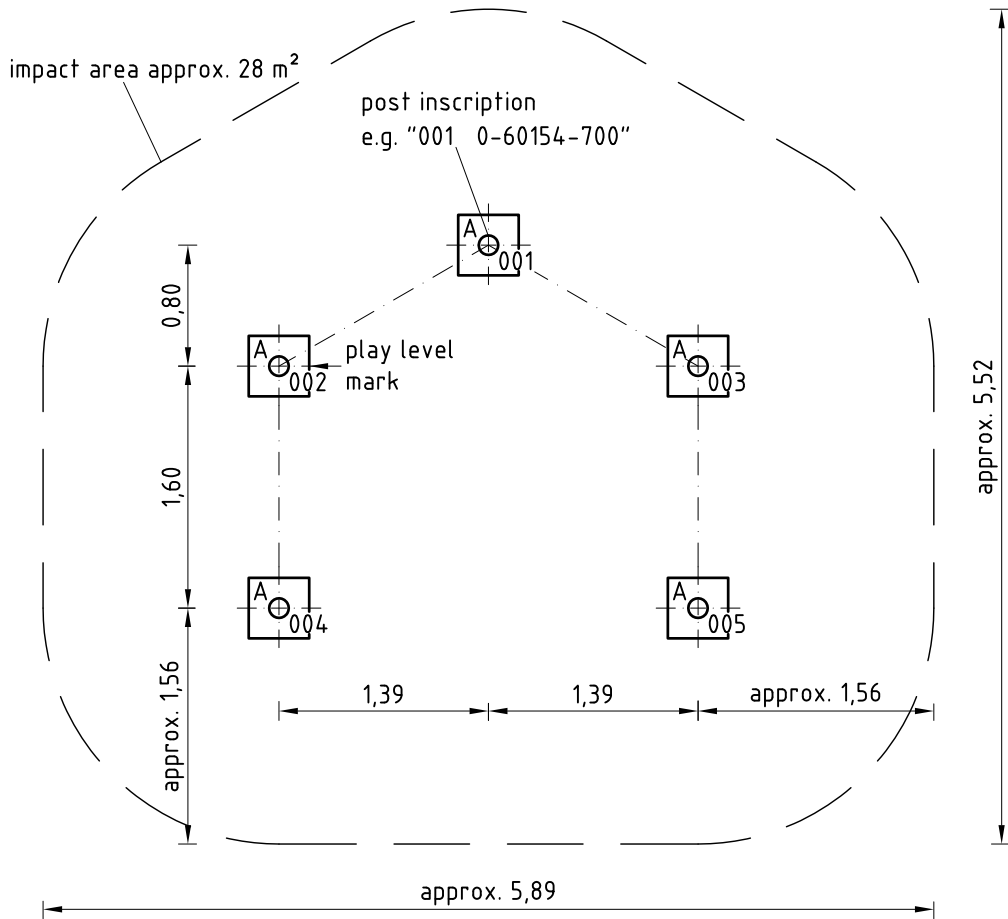
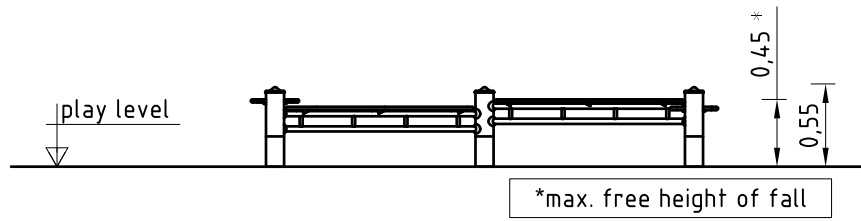

Item: **0-60154-700**
K&K Wavebench

Order:

1299194

Location:

Building Project:

16 x SFRS1230004 Standard bolting of climbing bar, ramp etc. to robinia posts with countersunk holes

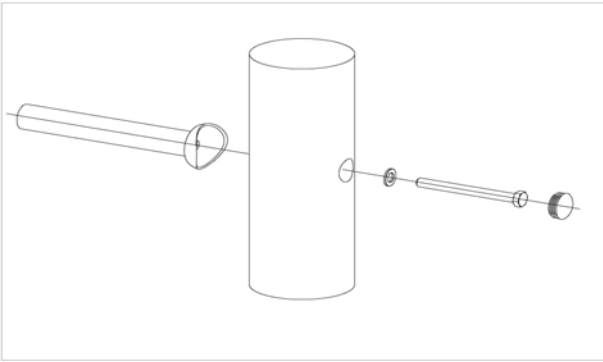

per SC	Total	K&K-Item	Marking
1 x	16 x	3430129	Washer Ø 14 DIN1440 A2
1 x	16 x	3300016	Cover cap (grey) for drill holes Ø 30-34 mm, domed made of polyethylene/ SL36G
1 x	16 x	3400701	Hexagon head cap screw M12 x 130 DIN931 A2 with screw retention coating/FGB red

1 x SFWZ0000014 Lubricating metal, bag (4g)



per SC	Total	K&K-Item	Marking
1 x	1 x	5300024	lubricating metal 4g