

platform orientation
1:100

necessarily keep to the platform orientation illustrated (plank direction) to meet the requirements of the standard for playground equipment EN 1176-1 concerning entrapment of clothing.

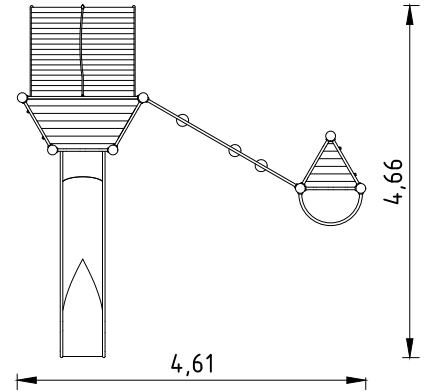

1. Assign a device location considering the space requirements (impact area). Slide direction recommended: north-east or in half-shade of trees.
2. Excavate soil for foundations, according to drawing.
Please note: To achieve maximum stability and a safe installation, a moderate level of soil solubility is required.
3. Pour in a drain layer of gravel of approx. 10 cm thickness between the bottom of the posts and plain base of foundation.
4. Insert reinforcing steel into the corresponding holes of the posts.
5. Place posts type A according to the corresponding number (see foundation layout) into the respective foundation hole. Play level mark (=aluminium blind rivet) complies with the installation depth. Align every post by means of the play level mark facing into the same direction (see detail or foundation layout).

6. For installation of the pre-assembled components and/or single parts, the screws slightly have to be lubricated with installation paste!

Screw together platforms and posts by using the middle hole in the mounting brackets.

Tighten all screws after having aligned all components.

Install the slide exit with an inclination of 5° in sliding direction.

Screw connections see details in attached list.

7. Grout foundations with compressed concrete C20/25, chamfer and round off the edges, cover the foundations with a surface which meets the requirements for impact attenuation so that the critical fall height of the surfacing is equal to, or greater than, the free height of fall of the equipment (acc. to EN 1176-1). The run-out section fall zone must have surfacing with a critical fall height of at least 1000mm (acc. to EN 1176-3).
8. Release for play after concrete foundations have set.
9. According to maintenance instructions, check all screw connections after 4-5 weeks and retighten, if necessary.

Please ensure that all special tools supplied (e.g. Allen key for secured Allen screws etc.) and all specific documents which are or may be useful for safety management acc. to EN 1176-7 (e.g. invoice, delivery note, order acknowledgement, installation instructions, maintenance instructions) are forwarded to the persons responsible.

Necessarily insert all attachment parts before tightening the screws. It is NOT possible to insert them afterwards.

platform fastening
1:10

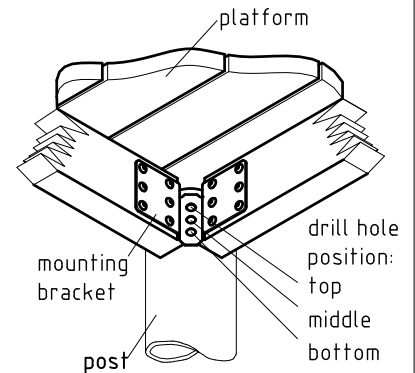

detail of check mark
1:5

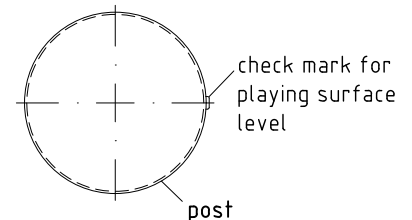

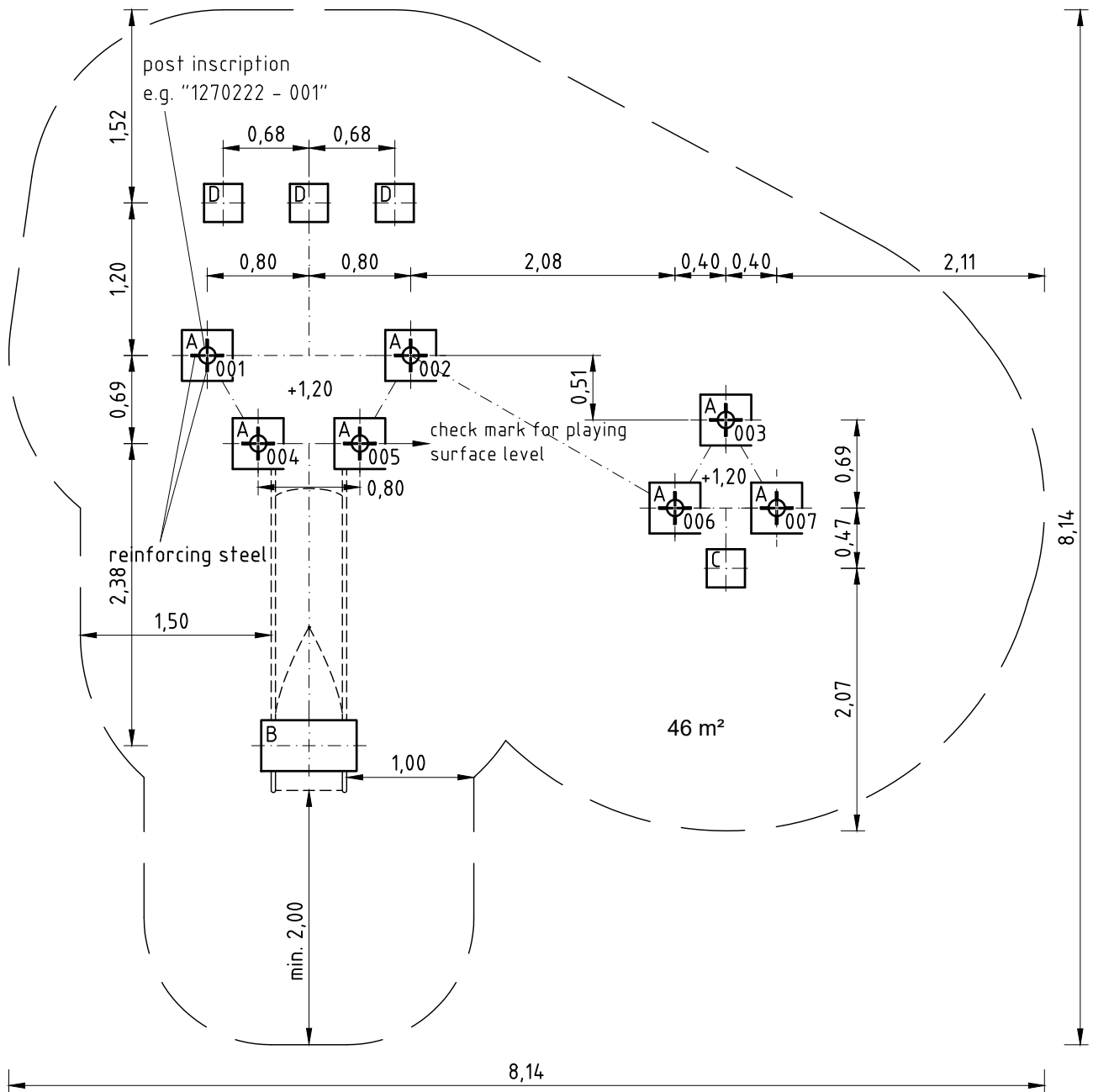
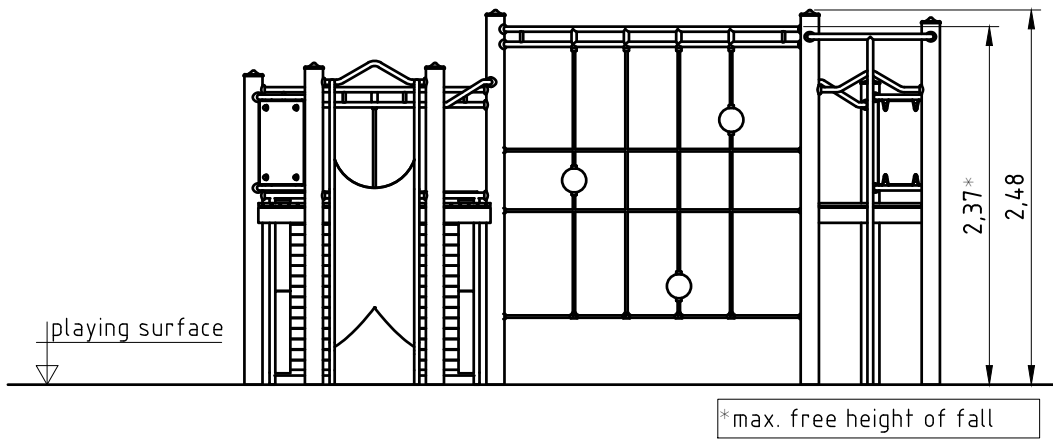

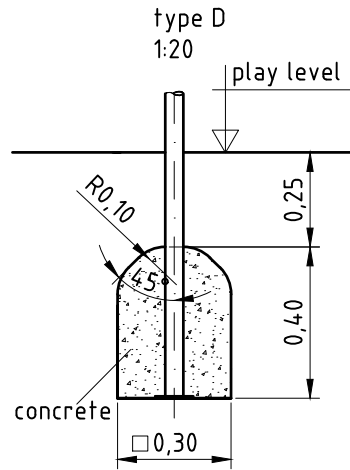
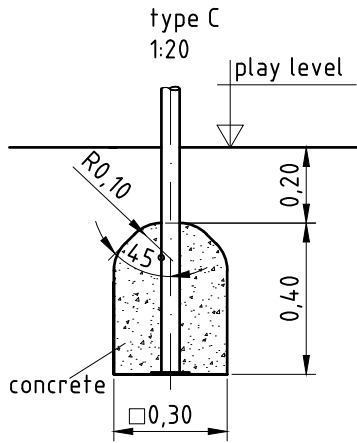
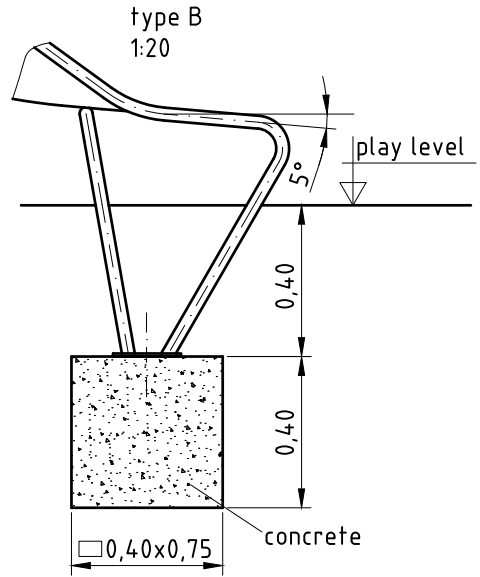
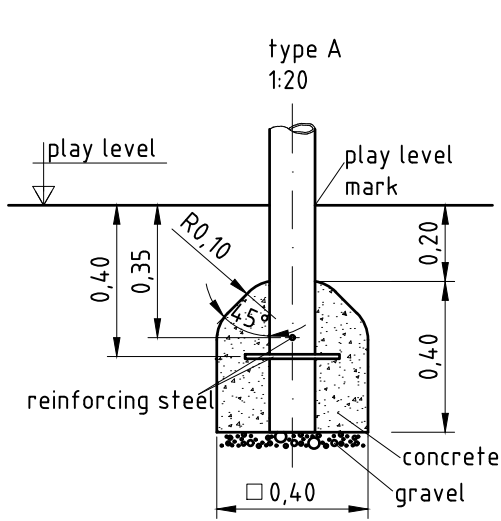

Installation of climbing net
1:50

Insert horizontal rope ends into the bushes until the metal sleeve pressed-on the end is located behind the lateral drill. Center the net with average distances A and B.

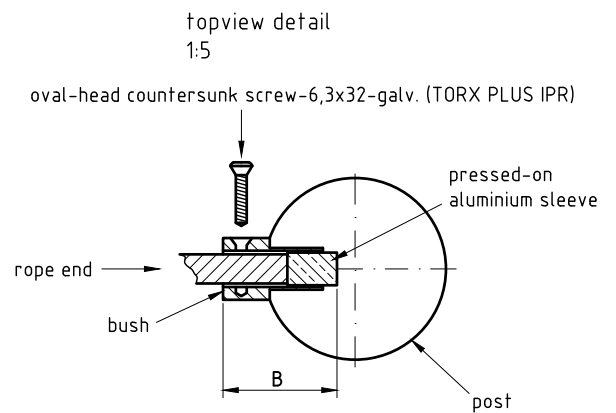
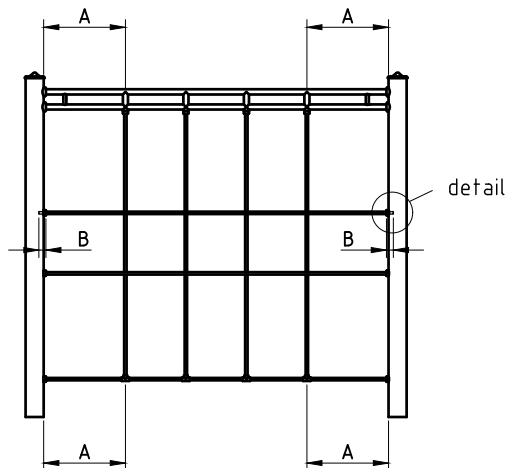

Item: **0-21540-501**

Order:

1291935

K&K Climbing Combination

Location:

Building Project:

7 x SFES120001 Fixing of platform at stainless steel post nut on platform site

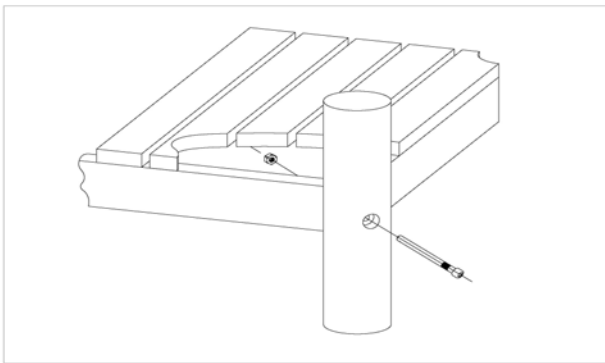

per SC	Total	K&K-Item	Marking
1 x	7 x	3430021	Safety nut M12 DIN985 A2
1 x	7 x	2030651	Cheese head screw M12 x 125 with pin and blue colour mark

30 x SFES1210001 Standard bolting of add-on pieces intended to connect ES120-add-on pieces (except platforms) at support post

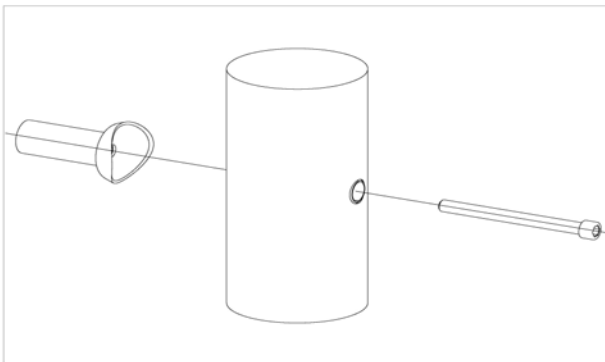

per SC	Total	K&K-Item	Marking
1 x	30 x	2030168	Cheese head screw M12x140 with pin Intended to connect ES120-add-on pieces (except platforms) at support post

6 x SFAS1230005 Climbing net/-rope at vertical post

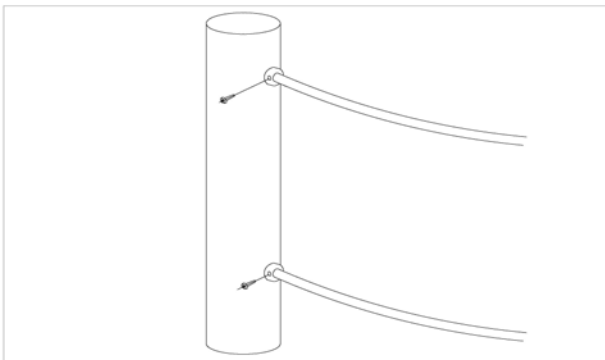

per SC	Total	K&K-Item	Marking
1 x	6 x	3400515	Oval head countersunk screw Torx Ø 6,3 x 32 A2

1 x SFAS1070006 Slide-run-out-section (up to 2.00 m) on foundation

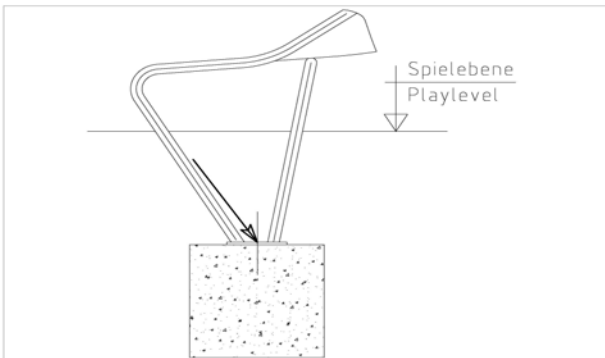

per SC	Total	K&K-Item	Marking
2 x	2 x	1070365	Stonescrew set for slide-runout M12 x 160

Item: **0-21540-501**

Order:

1291935

K&K Climbing Combination

Location:

Building Project:

7 x SFES1270001 Reinforcing steel for stainless steel post



per SC	Total	K&K-Item	Marking
2 x	14 x	2030199	Reinforcing steel ES120 Ø 12 x 250 1.4301

1 x SFWZ0000009 Hexagon insert socket driver 10mm 1/2" with borehole for Pin



per SC	Total	K&K-Item	Marking
1 x	1 x	2030170	Hexagon insert socket driver 10 mm 1/2" with drill hole for Pin

1 x SFWZ0000010 safety bit TORX 5-star 30 IPR x 25 with drillhole for pin



per SC	Total	K&K-Item	Marking
1 x	1 x	3490038	Safety bit TORX 5-star 30 IPR x 25 with drill hole

1 x SFWZ0000012 Lubricating metal (30g box) incl. brush



per SC	Total	K&K-Item	Marking
1 x	1 x	5300039	Lubricating metal box à 30g
1 x	1 x	5200026	Brush for lubricating metal