

Some additional instructions for the installation of K&K Wide bedway slides

- The specified installation height of the slide must be observed (distance between play level and bottom edge of the fastening flange).
- The starting section of the chute must be installed horizontally.
- All (straight, curved or waded sections) of the slide assembly must be installed with the correct inclination (measured in the centre of the slide trough). This does not apply to the run-out section.
- The slide support has to be installed such that it effectively supports the slide, that the curved or waded sections are properly positioned without a deviation from the inclination specified.
- The run-out section must be installed with an inclination of 5°.

1. Assign a location for the bedway slide considering the space requirements/impact area. Slide direction recommended: north-east or in half-shade of trees.
2. Excavate foundation hole for run-out section acc. to drawing. Please observe the additional details given.
3. Use e.g. lifting gear to carry the bedway slide to the intended mounting place. Fasten flange of slide entrance using the two holes for M12.
4. Grout foundation with compressed concrete C20/25 and insert the stone bolts at the same time.
5. Release for play after concrete foundations have set.

Please take care that all special tools (e.g. special Allen key for secured Allen screws etc.) and all specific documents which are or may be useful for a safety management (e.g. invoice, delivery note, order acknowledgement, installation instructions, maintenance instructions) are forwarded to the responsible persons.

Plug-in base for slide support 1:20

to be mounted as follows:

If necessary, shorten stainless steel post of slide support to the required length (with adequate appliance e.g. angle grinder). Insert base from below into the stainless steel post.

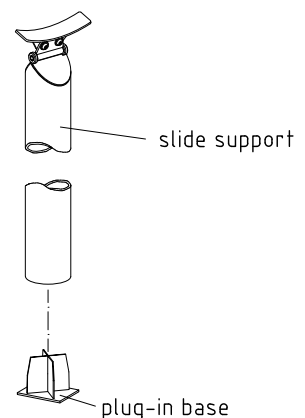

Option 1 : hillside situation
 Exemplary course of the hill
 Please consider planning specification
 and/or the instructions of architect on site.
 Cut slide support acc. to requirements or dig
 deeper acc. to course of the hill.

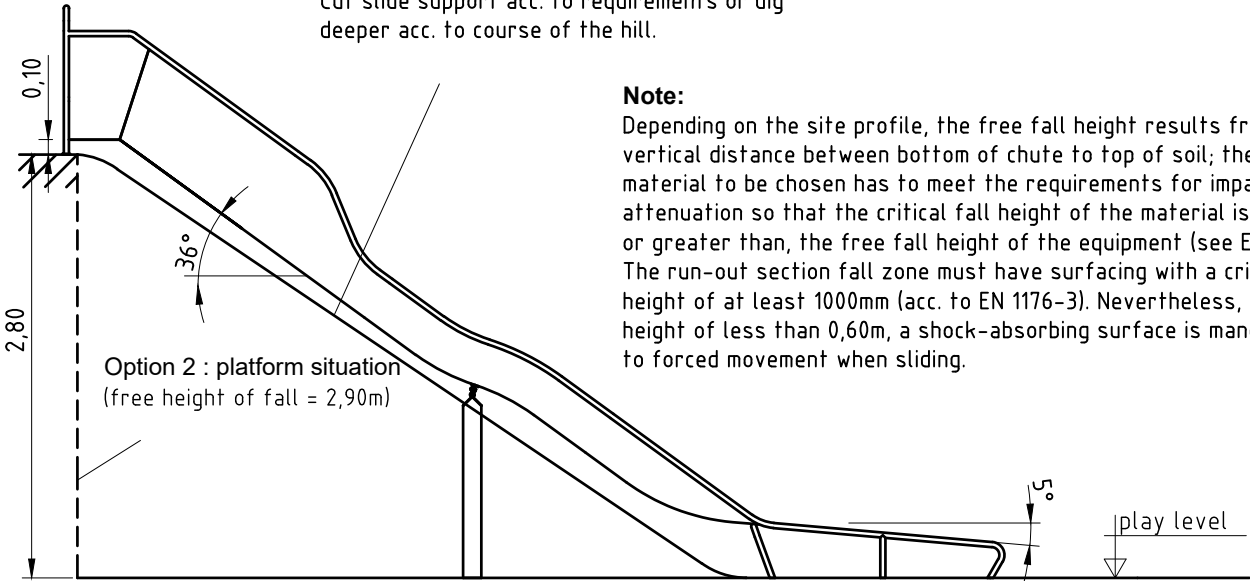

Note:

Depending on the site profile, the free fall height results from the vertical distance between bottom of chute to top of soil; the surfacing material to be chosen has to meet the requirements for impact attenuation so that the critical fall height of the material is equal to, or greater than, the free fall height of the equipment (see EN 1176-1). The run-out section fall zone must have surfacing with a critical fall height of at least 1000mm (acc. to EN 1176-3). Nevertheless, with a fall height of less than 0,60m, a shock-absorbing surface is mandatory due to forced movement when sliding.

Below the entrance section, an additional ground coating of at least 0,20 m is necessary.

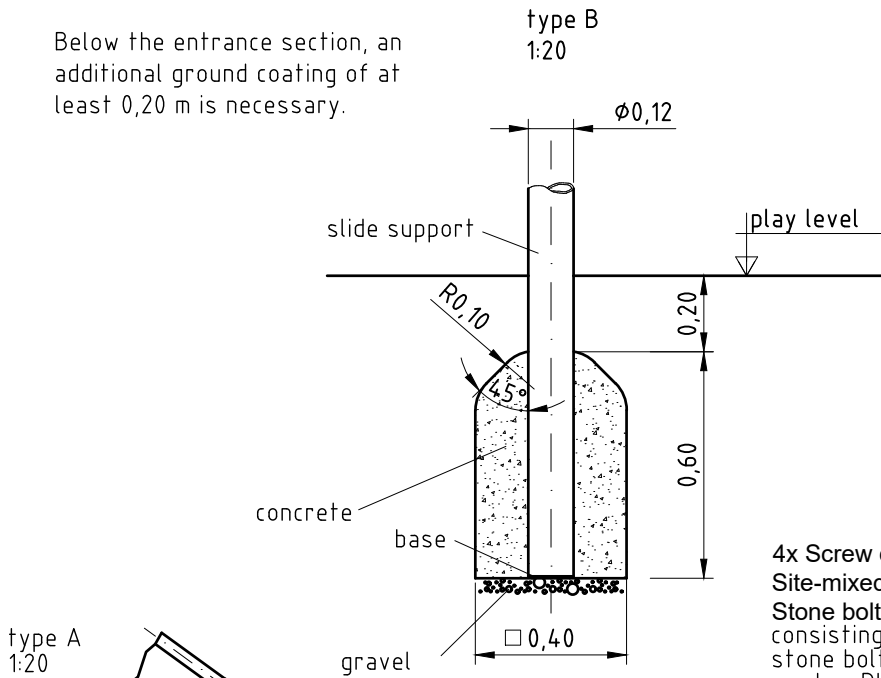

4x Screw connection of attached part
 Site-mixed concrete foundation.
 Stone bolt attached into foundation
 consisting of:
 stone bolt DIN 529-M12x160
 washer DIN 125-13
 hexagon nut DIN 985-M12

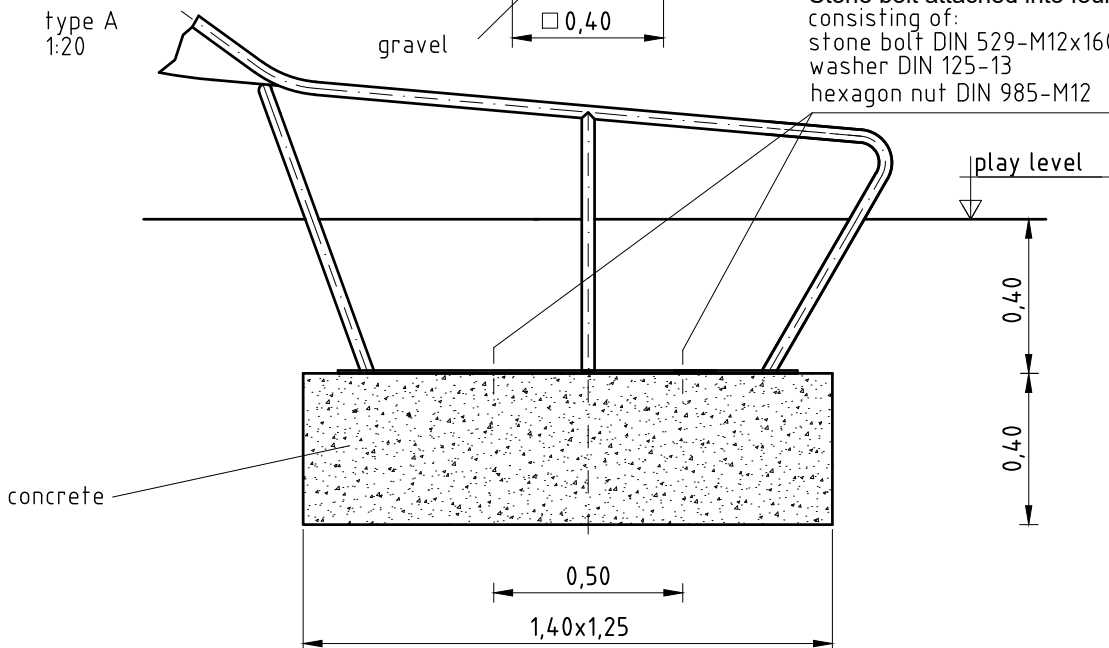

Installation

