

(exemplary colour illustration)

Item

057046000

Chin-up-bar exerciser

Mounting instructions

1. for installation as *permanently installed public **playground equipment*** according to **EN 1176** (Pages: 1-2)
2. for installation as *permanently installed outdoor **fitness equipment*** according to **EN 16630** (Pages: 3-4)



The delivered product is labelled with a round sticker stating the standard intended for use (EN 16630 or EN 1176).



Mounting instructions for installation as permanently installed public **playground equipment** according to **EN 1176**

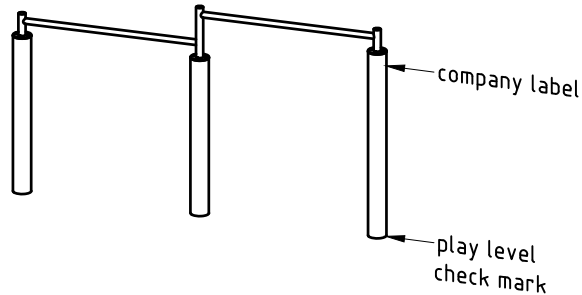

1. Assign a device location considering the space requirement (impact area).
2. Excavate soil for foundations, according to drawing.
Please note: To achieve maximum stability and a safe installation, a moderate level of soil solubility is required.
3. Pour in a drain layer of gravel of approx. 10 cm thickness between the bottom of the posts and plain base of foundation.
4. Place posts type A according to the corresponding number (see foundation layout) into the respective foundation hole. Play level mark (welded pin) complies with the installation depth. Align every post by means of the play level mark facing into the same direction (see detail or foundation layout).
5. **For installation of the pre-assembled components and/or single parts, the screws slightly have to be lubricated with installation paste!**
4. Grout foundations with compressed concrete C20/25, chamfer and round off the edges. The soil characteristics of the area surrounding the equipment must have an appropriate level of shock absorption corresponding to the free height of fall (according to EN 1176-1).
5. Release for play after concrete foundations have set.
6. According to maintenance instructions, check all screw connections after 4-5 weeks and retighten, if necessary.

detail of play level mark
1:5

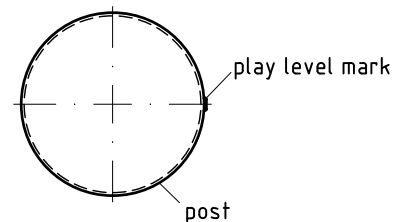

Please ensure that all special tools supplied (e.g. Allen key for secured Allen screws etc.) and all specific documents which are or may be useful for safety management acc. to EN 1176-7 (e.g. invoice, delivery note, order acknowledgement, installation instructions, maintenance instructions) are forwarded to the persons responsible.

Necessarily insert all attachment parts before tightening the screws. It is NOT possible to insert them afterwards.

Mounting instructions for installation as permanently installed public **playground equipment** according to **EN 1176**

www.kaiser-kuehne.com T. +49 (0) 42 54 / 93 15-0

© Kaiser & Kühne Freizeitgeräte D-27324 Eystrup

Installation

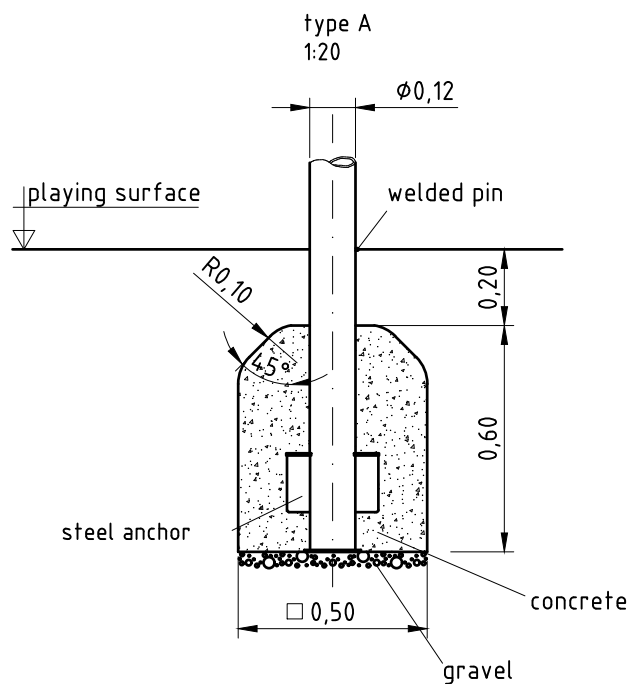
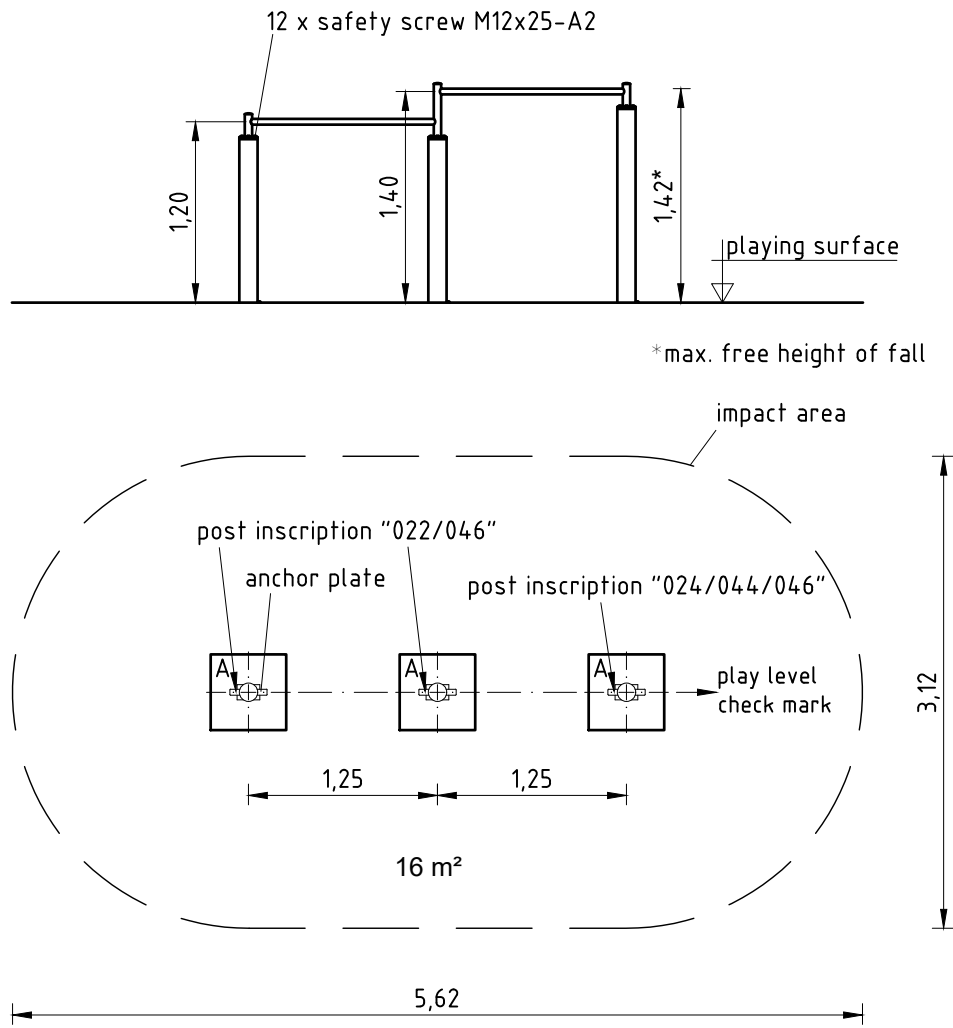

Mounting instructions for installation as permanently installed outdoor **fitness equipment** according to **EN 16630**

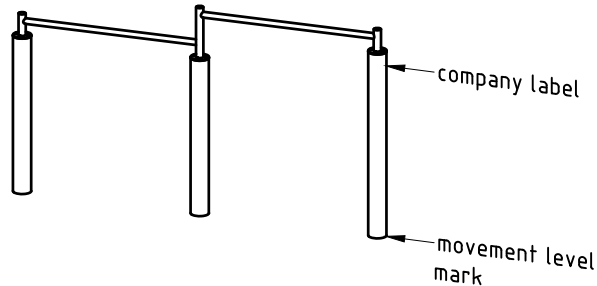

1. Assign a device location considering the space requirement (movement area).
2. Excavate soil for foundations, according to drawing.
Please note: To achieve maximum stability and a safe installation, a moderate level of soil solubility is required.
3. Pour in a drain layer of gravel of approx. 10 cm thickness between the bottom of the posts and plain base of foundation.
4. Place posts type A according to the corresponding number (see foundation layout) into the respective foundation hole. Movement level mark (=aluminium blind rivet) complies with the installation depth. Align every post by means of the play level mark facing into the same direction (see detail or foundation layout).
- 5. For installation of the pre-assembled components and/or single parts, the screws slightly have to be lubricated with installation paste!**
4. Grout foundations with compressed concrete C20/25, chamfer and round off the edges. The soil characteristics of the area surrounding the equipment must have an appropriate level of shock absorption corresponding to the free height of fall (according to EN 16630).
5. Release for play after concrete foundations have set.
6. According to maintenance instructions, check all screw connections after 4-5 weeks and retighten, if necessary.

detail of check mark
1:5

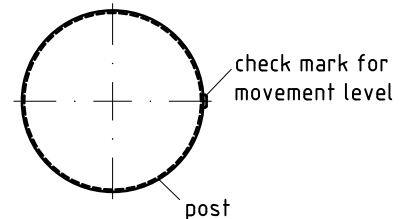

Please ensure that all special tools supplied (e.g. Allen key for secured Allen screws etc.) and all specific documents which are or may be useful for a safety management (e.g. invoice, delivery note, order acknowledgement, installation instructions, maintenance instructions) are forwarded to the persons responsible.

Necessarily insert all attachment parts before tightening the screws. It is NOT possible to insert them afterwards.

Mounting instructions for installation as permanently installed outdoor **fitness equipment** according to **EN 16630**

www.kaiser-kuehne.com T +49 42 54 / 93 15-0

© Kaiser & Kühne Freizeitgeräte D-27324 Eystrup

Installation

