

1. Assign a device location considering the space requirements (impact area). Slide direction recommended: north-east or in half-shade of trees.
2. Excavate soil for foundations, according to drawing. Please note: To achieve maximum stability and a safe installation, a moderate level of soil solubility is required.
3. Pour in a drain layer of gravel of approx. 10 cm thickness between the bottom of the posts and plain base of foundation.
4. Insert reinforcing steel into the corresponding holes of the posts.
5. Place posts type A and B (see foundation layout) into the respective foundation hole, according to the corresponding number. Play level mark (=aluminium blind rivet) complies with the installation depth. Align both posts type B by means of the play level mark facing into the same direction (see detail or foundation layout).

6. For installation of the pre-assembled components and/or single parts, the screws slightly have to be lubricated with installation paste!

Screw together platform and posts by using the middle hole in the mounting brackets.

Tighten all screws after having aligned all components.

Install the slide exit with an inclination of 5° in sliding direction.

Screw connections see details in attached list.

We recommend not to insert the protection caps enclosed before first maintenance as they are only suitable for one-time use (see description in item No. 9).

7. Grout foundations with compressed concrete C20/25, chamfer and round off the edges, cover the foundations with a surface which meets the requirements for impact attenuation so that its critical fall height is equal to or greater than the maximum free height of fall of the equipment (acc. to EN 1176-1). The run-out section fall zone must have surfacing with a critical fall height of at least 1000 mm (acc. to EN 1176-3).
8. Release for play after concrete foundations have set.
9. According to maintenance instructions, check all screw connections after 4-5 weeks and retighten, if necessary. Afterwards cover the screw heads with the top part of the protection caps. Strongly pound them (e.g. by using a plastic mallet) until they audibly snap into the base part groove.

Please ensure that all special tools supplied (e.g. Allen key for secured Allen screws etc.) and all specific documents which are or may be useful for safety management acc. to EN 1176-7 (e.g. invoice, delivery note, order acknowledgement, installation instructions, maintenance instructions) are forwarded to the persons responsible.

Necessarily insert all attachment parts before tightening the screws. It is NOT possible to insert them afterwards.

platform orientation
1:100

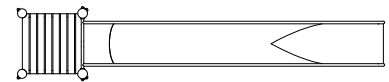

detail of play level mark
1:5

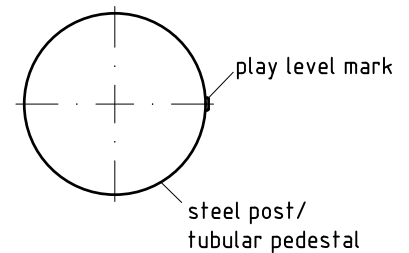

platform fastening
1:10

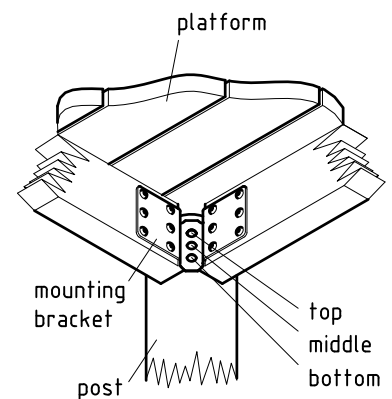

* max. free height of fall at slide entrance. Depending on the site profile, the free fall height (hx) and the size of the impact area result from the vertical distance between the bottom of the chute and ground level.
 The surfacing material for the impact area within the sliding section must meet the requirements given in table 4 (see EN 1176-1). The shock-absorbing characteristics of any other material to be chosen must be certified in accordance with EN 1177.
 The run-out section fall zone must have surfacing with a critical fall height of at least 1000mm (acc. to EN 1176-3).

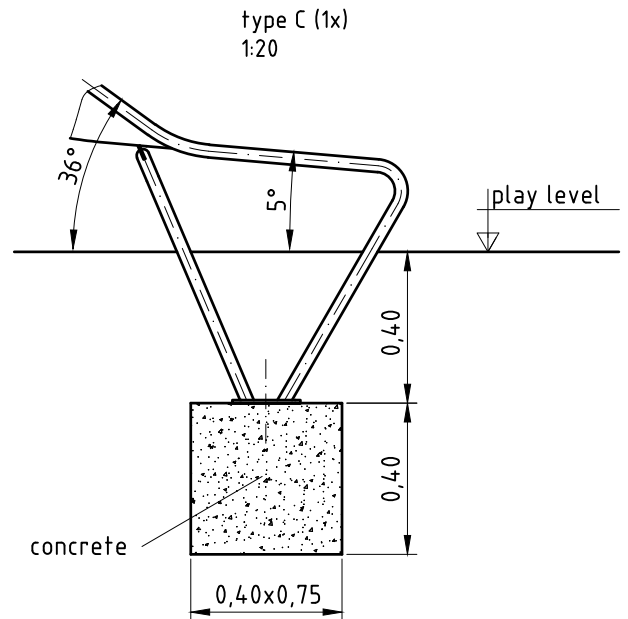
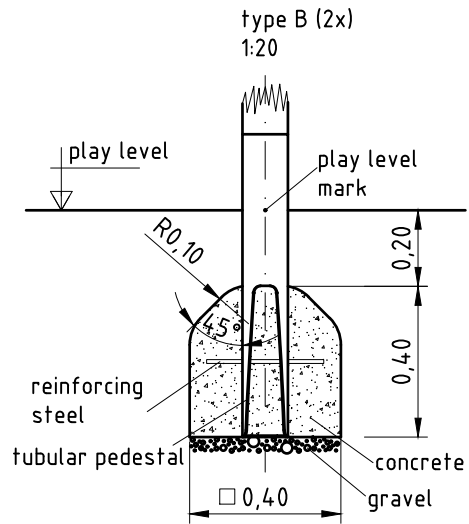
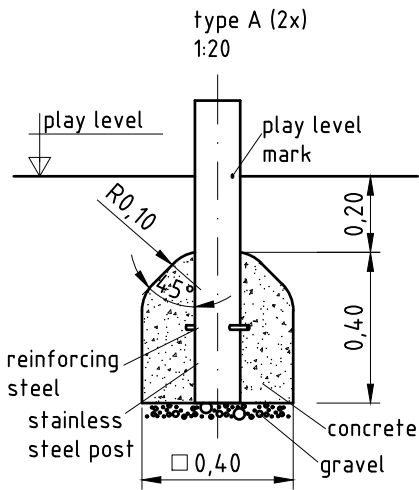
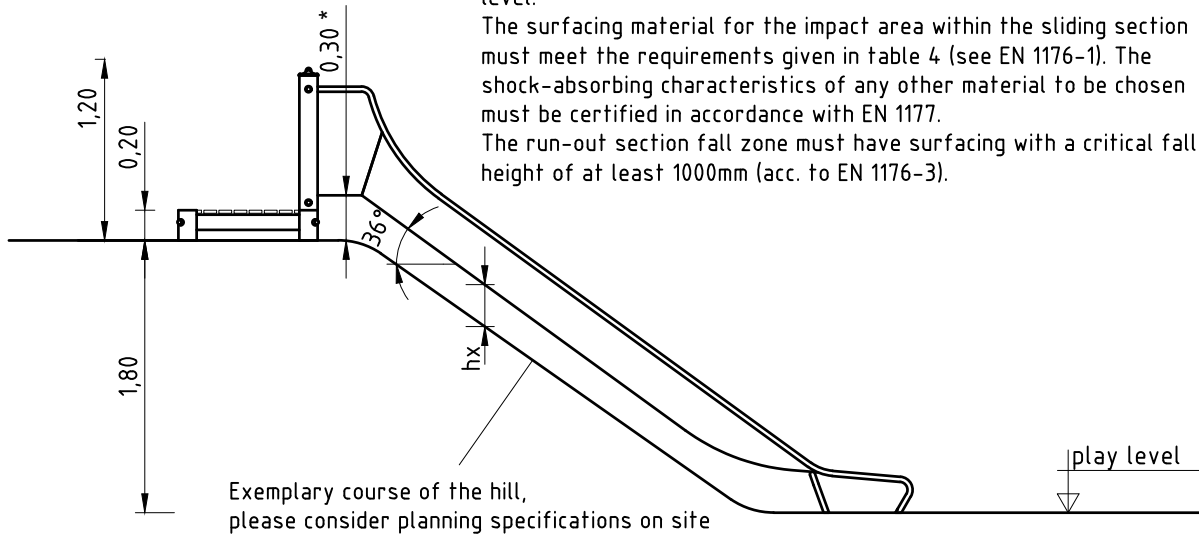

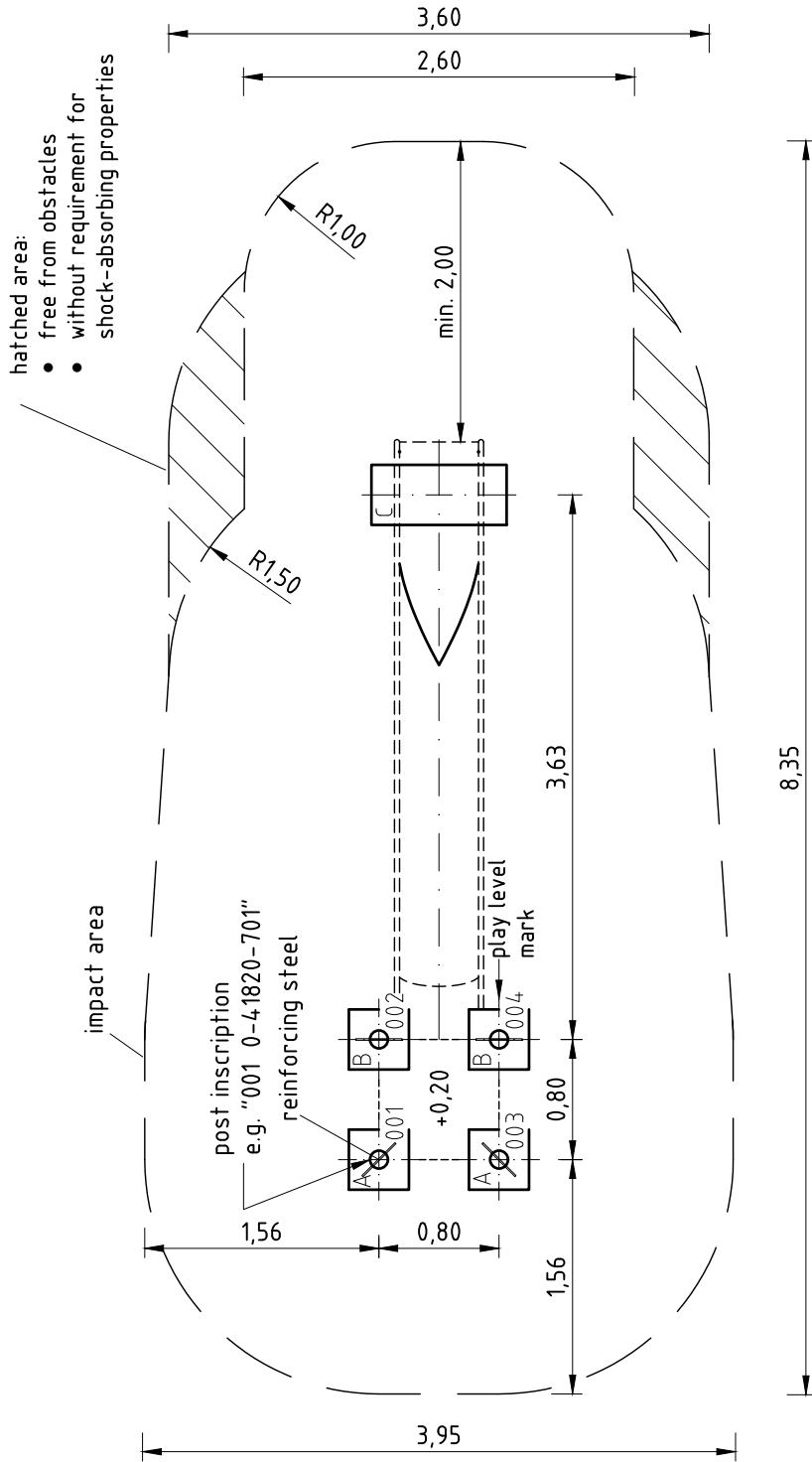

Item: **041820701**

Order:

1291352

Hill slide (2,00) with starting platform 0,20

Location:

Building Project:

4 x SFES1200014 Platform at stainless steel post (hexagon screw with protective cap/nut platform-sided)

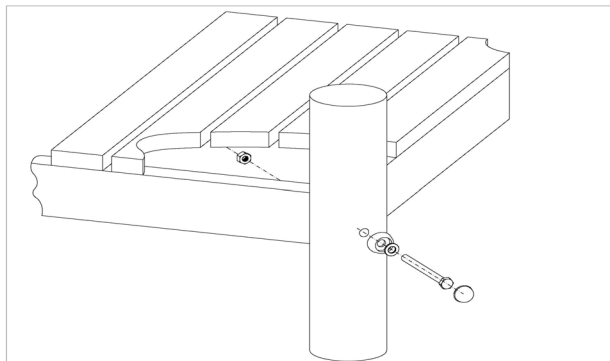

per SC	Total	K&K-Item	Marking
1 x	4 x	3430025	Washer Ø 13 DIN125 A2
1 x	4 x	3300055	Screw cap upper part M12
1 x	4 x	3300054	Screw cap lower part, domed, M12
1 x	4 x	3430021	Lock nut M12 DIN985 A2
1 x	4 x	3400363	Hexagon head cap screw M12 x 150 DIN931 A2

4 x SFRS1210001 Standard bolting of components to Robinia posts (non-countersunk drilling)

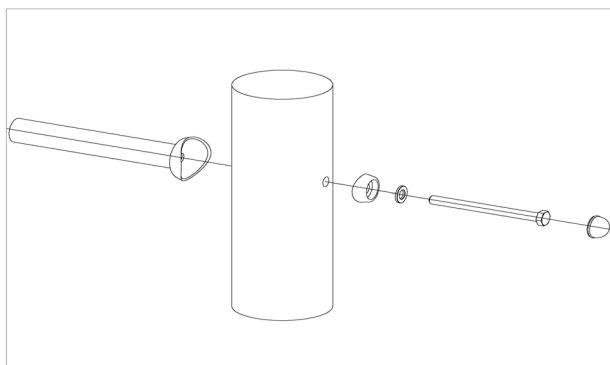

per SC	Total	K&K-Item	Marking
1 x	4 x	3300055	Screw cap upper part M12
1 x	4 x	3300054	Screw cap lower part, domed, M12
1 x	4 x	3430025	Washer Ø 13 DIN125 A2
1 x	4 x	3400702	Hexagon head cap screw M12 x 160 DIN931 A2 with screw security coating FGB red

4 x SFAS1270001 Reinforcing steel bar for posts



per SC	Total	K&K-Item	Marking
1 x	4 x	2130000	Reinforcing steel Ø 10 x 310 DIN 488

2 x SFXS1070006 Slide run-out section (up to 2,00 m) on foundation stone bolt assembly

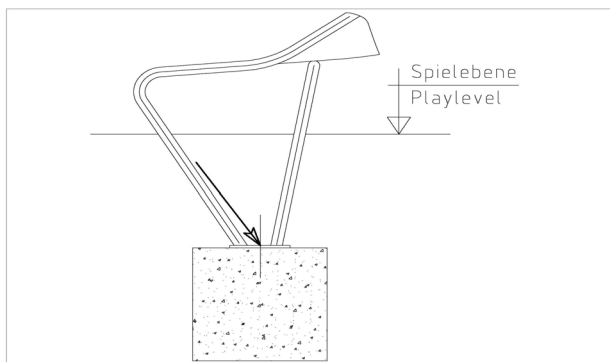

per SC	Total	K&K-Item	Marking
1 x	2 x	1070365	Set of stone bolts for slide run-out section M12x160

Item: **041820701**

Order:

1291352

Hill slide (2,00) with starting platform 0,20

Location:

Building Project:

1 x SFWZ0000014 Lubricating metal, bag (4 g)

per SC	Total	K&K-Item	Marking
1 x	1 x	5300024	Metaflux fitting lubricant 2x4 g

