

1. Assign a device location considering the space requirements (impact area).  
Slide direction recommended: north-east or in half-shade of trees.
2. Excavate soil for foundations, according to drawing.  
Please note: To achieve maximum stability and a safe installation, a moderate level of soil solubility is required.
3. Pour in a drain layer of gravel of approx. 10 cm thickness between the bottom of the posts and plain base of foundation.
4. Insert reinforcing steel into the corresponding holes of the posts.
5. Place posts type A and B (see foundation layout) into the respective foundation hole, according to the corresponding number. Play level mark (=aluminium blind rivet) complies with the installation depth. Align both posts type B by means of the play level mark facing into the same direction (see detail or foundation layout).

**6. For installation of the pre-assembled components and/or single parts, the screws slightly have to be lubricated with installation paste!**

Screw together platform and posts by using the middle hole in the mounting brackets.

**Tighten all screws after having aligned all components.**

Install the slide exit with an inclination of 5° in sliding direction.

Screw connections see details in attached list.

We recommend not to insert the protection caps enclosed before first maintenance as they are only suitable for one-time use (see description in item No. 9).

7. Grout foundations with compressed concrete C20/25, chamfer and round off the edges, cover the foundations with a surface which meets the requirements for impact attenuation so that its critical fall height is equal to or greater than the maximum free height of fall of the equipment (acc. to EN 1176-1). The run-out section fall zone must have surfacing with a critical fall height of at least 1000 mm (acc. to EN 1176-3).
8. Release for play after concrete foundations have set.
9. According to maintenance instructions, check all screw connections after 4-5 weeks and retighten, if necessary. Afterwards cover the screw heads with the top part of the protection caps. Strongly pound them (e.g. by using a plastic mallet) until they audibly snap into the base part groove.

Please ensure that all special tools supplied (e.g. Allen key for secured Allen screws etc.) and all specific documents which are or may be useful for safety management acc. to EN 1176-7 (e.g. invoice, delivery note, order acknowledgement, installation instructions, maintenance instructions) are forwarded to the persons responsible.

**Necessarily insert all attachment parts before tightening the screws. It is NOT possible to insert them afterwards.**

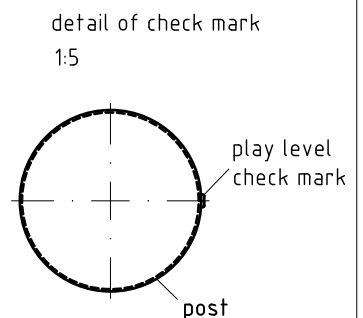
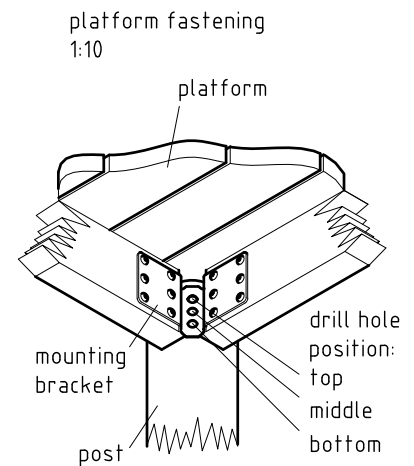

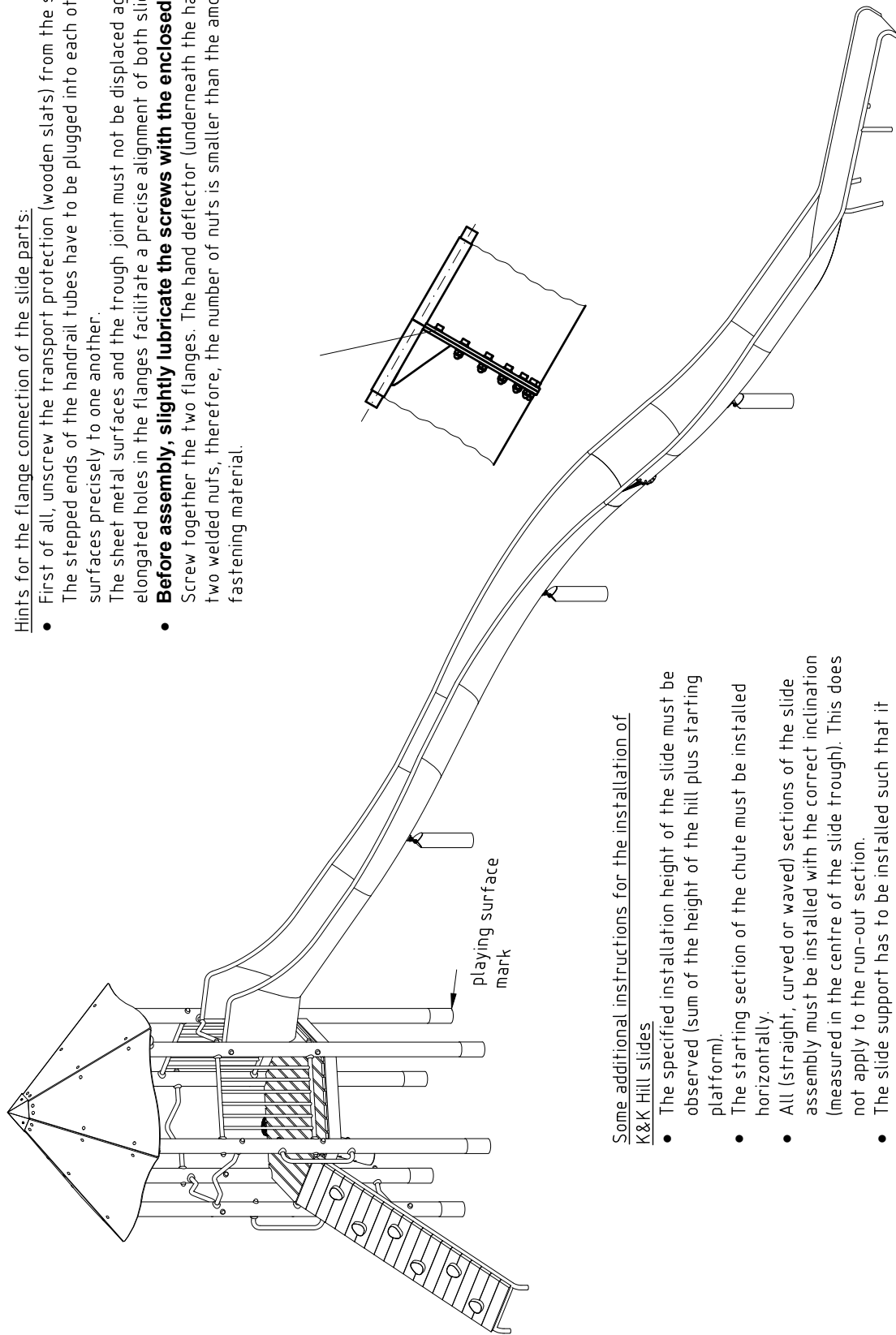

Hints for the flange connection of the slide parts:

- First of all, unscrew the transport protection (wooden slats) from the slide parts.
- The stepped ends of the handrail tubes have to be plugged into each other. Adjust both flange surfaces precisely to one another.
- The sheet metal surfaces and the trough joint must not be displaced against each other. The elongated holes in the flanges facilitate a precise alignment of both slide parts.
- **Before assembly, slightly lubricate the screws with the enclosed installation paste.** Screw together the two flanges. The hand deflector (underneath the handrail) is provided with two welded nuts, therefore, the number of nuts is smaller than the amount of the other fastening material.

Some additional instructions for the installation of K&K Hill slides

- The specified installation height of the slide must be observed (sum of the height of the hill plus starting platform).
- The starting section of the chute must be installed horizontally.
- All (straight, curved or waved) sections of the slide assembly must be installed with the correct inclination (measured in the centre of the slide trough). This does not apply to the run-out section.
- The slide support has to be installed such that it effectively supports the slide, that the turns (curves) are properly positioned without a deviation from the inclination specified.
- The run-out section must be installed with an inclination of 5°.

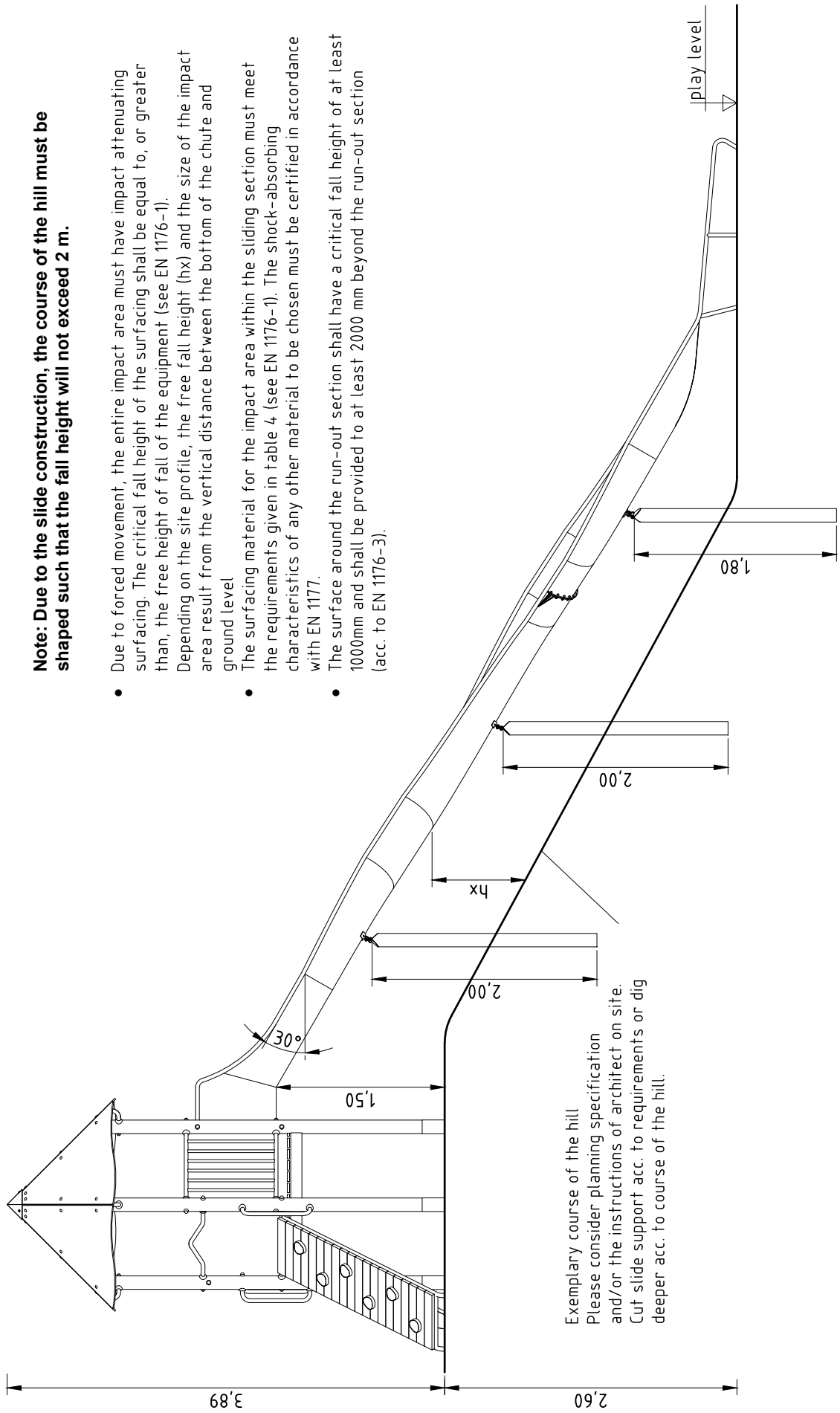

**Note: Due to the slide construction, the course of the hill must be shaped such that the fall height will not exceed 2 m.**

- Due to forced movement, the entire impact area must have impact attenuating surfacing. The critical fall height of the surfacing shall be equal to, or greater than, the free height of fall of the equipment (see EN 1176-1). Depending on the site profile, the free fall height (hx) and the size of the impact area result from the vertical distance between the bottom of the chute and ground level
- The surfacing material for the impact area within the sliding section must meet the requirements given in table 4 (see EN 1176-1). The shock-absorbing characteristics of any other material to be chosen must be certified in accordance with EN 1177.
- The surface around the run-out section shall have a critical fall height of at least 1000mm and shall be provided to at least 2000 mm beyond the run-out section (acc. to EN 1176-3).

Exemplary course of the hill  
Please consider planning specification  
and/or the instructions of architect on site.  
Cut slide support acc. to requirements or dig  
deeper acc. to course of the hill.

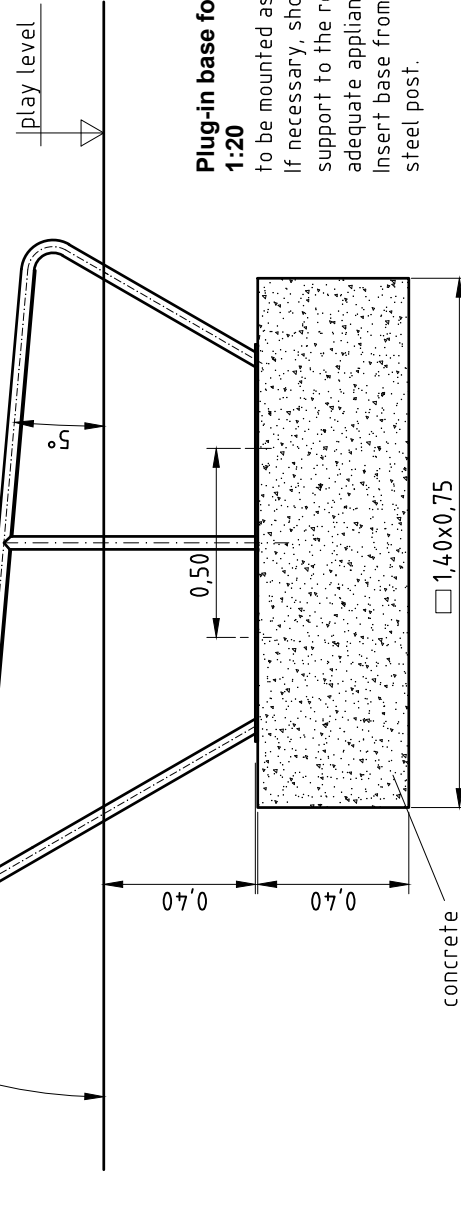
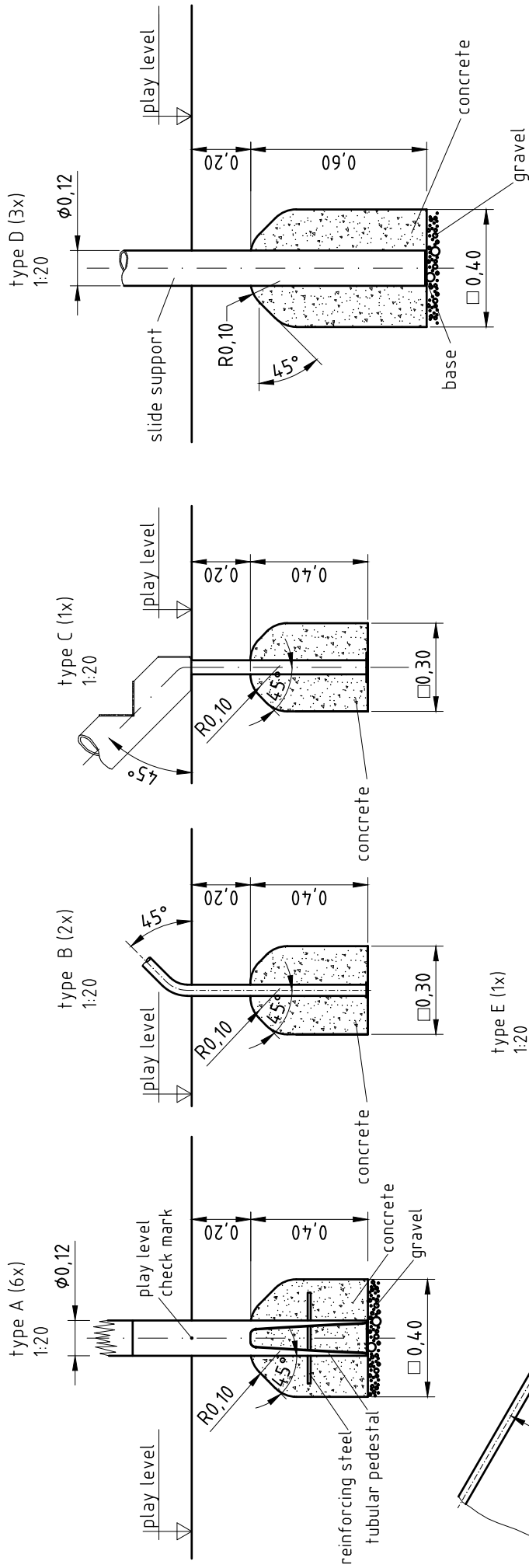

**Plug-in base for slide support 1:20**

to be mounted as follows:  
 If necessary, shorten stainless steel slide support to the required length (with adequate appliance e.g. angle grinder).  
 Insert base from below into the stainless steel post.

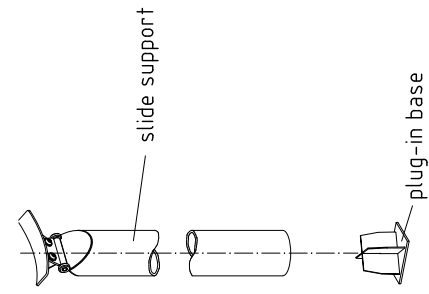

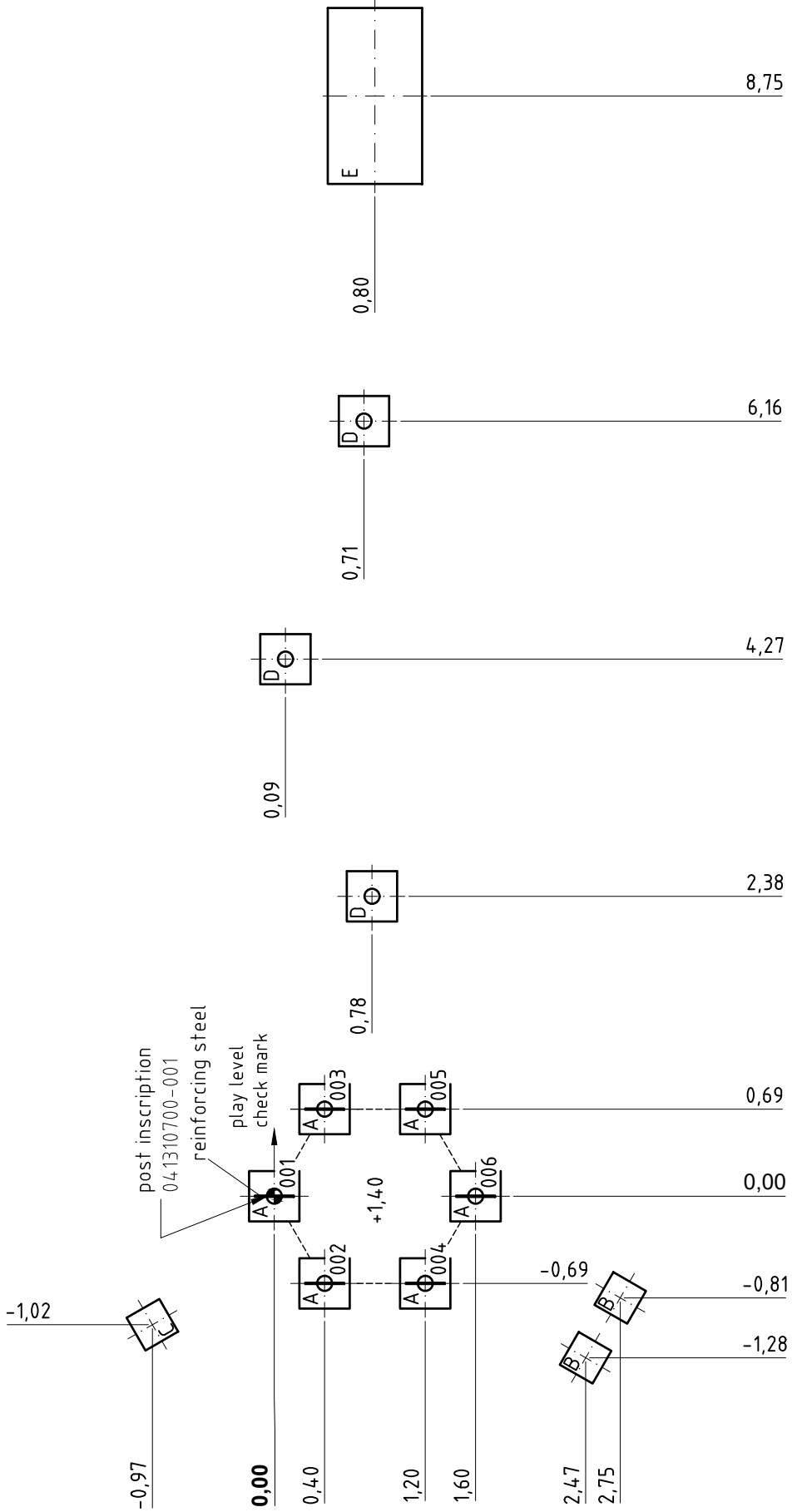

# Installation

Item-No.  
0-41310-700

Description  
Combi slide

Scale  
1:50

Date  
03/23 EB

Page  
5/6

The size of the impact area depends on the course of the hill. Example of a maximum fall height of 1,50 m.

hatched area:

- free from obstacles
- without requirement for shock-absorbing properties

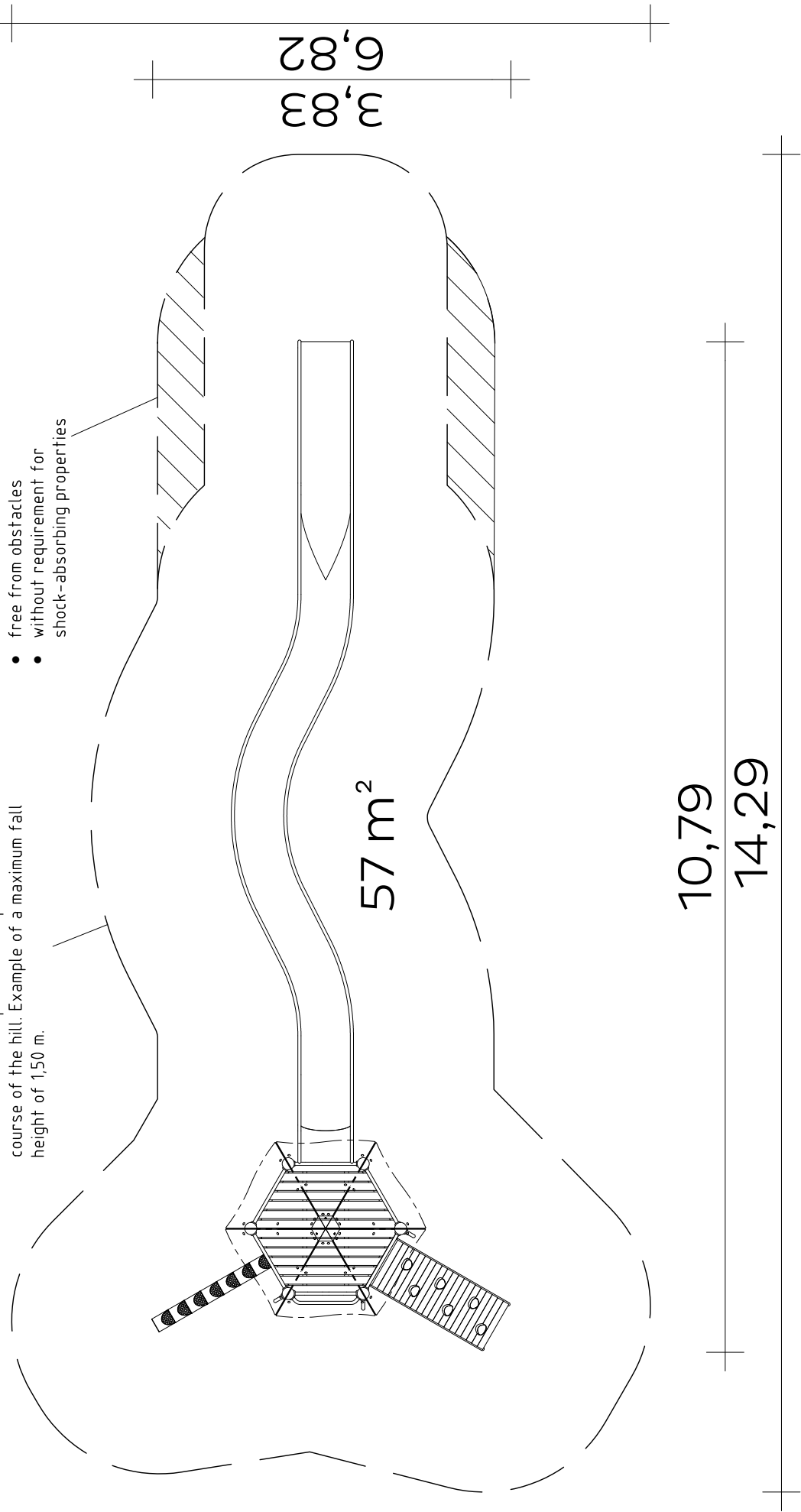

**Please note:**  
 Due to the format size, this installation is not to scale (apart from single details).  
 Please refer to the dimensions indicated.  
 An installation documentation scale 1:50 can be submitted on request.

**Item: 041310700**
**Order:**

1295318

Combi slide

Location:

Building Project:

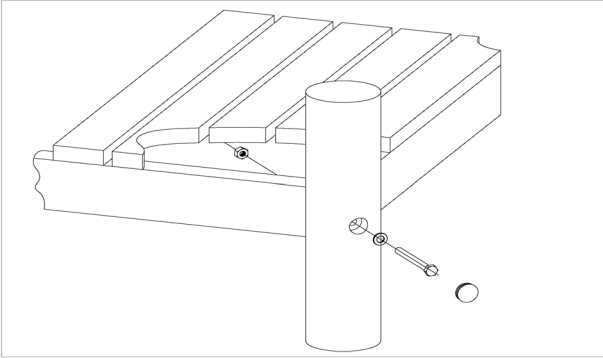
**6 x SFRS1200001 Platform at Robinia post, nut is platform-sided**

per SC	Total	K&K-Item	Marking
1 x	6 x	3430129	Washer Ø 14 DIN1440 A2
1 x	6 x	3430021	Lock nut M12 DIN985 A2
1 x	6 x	3300016	Grey domed plastic cover cap SL 36 G
1 x	6 x	3400700	Hexagon head screw M12 x 120 DIN931 A2 with screw security coating/FGB red

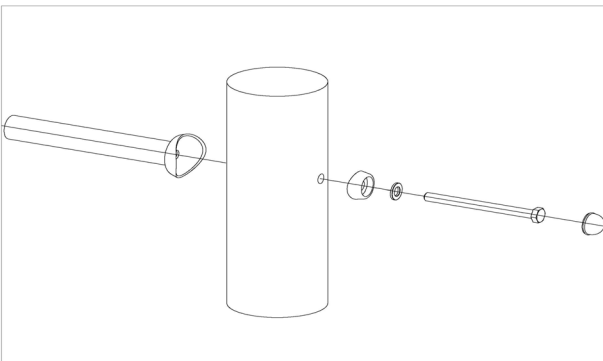
**36 x SFRS1210001 Standard bolting of components to Robinia posts (non-countersunk drilling)**

per SC	Total	K&K-Item	Marking
1 x	36 x	3300054	red protective screw cap - lower part, domed M12
1 x	36 x	3300055	red protective screw cap - upper part, M12
1 x	36 x	3430025	Washer Ø 13 DIN125 A2
1 x	36 x	3400702	Hexagon head cap screw M12 x 160 DIN931 A2 with screw security coating FGB red

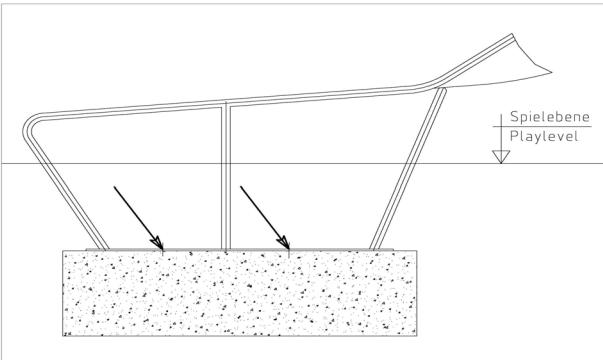
**4 x SFXS1070008 Slide run-out section (midi) stone bolt assembly**

per SC	Total	K&K-Item	Marking
1 x	4 x	1070365	Set of stone bolts for slide run-out section M12x160

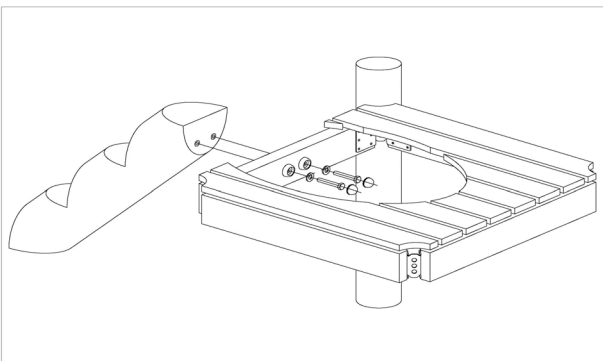
**2 x SFXS1230004 Climbing post fastening to platform joist**

per SC	Total	K&K-Item	Marking
1 x	2 x	3400414	hexagon head cap screw M12 x 75 DIN931 A2
1 x	2 x	3300055	red protective screw cap - upper part, M12
1 x	2 x	3430025	Washer Ø 13 DIN125 A2
1 x	2 x	3300045	Screw cover cap, flat, M 12 PA6 P1 (lower part) colour: red/RAL 2002

Item: **041310700**

Order:

1295318

Combi slide

Location:

Building Project:

**6 x SFAS1070004 Slide support post below hill slide**

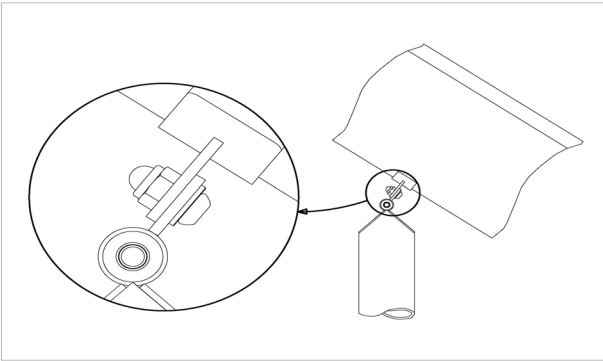

per SC	Total	K&K-Item	Marking
1 x	6 x	3430025	Washer Ø 13 DIN125 A2
1 x	6 x	3400622	Dome head security bolt M12x25 PinHexagon A2 safety coated thread

**11 x SFAS1070012 Flange connection of hill slide sections**

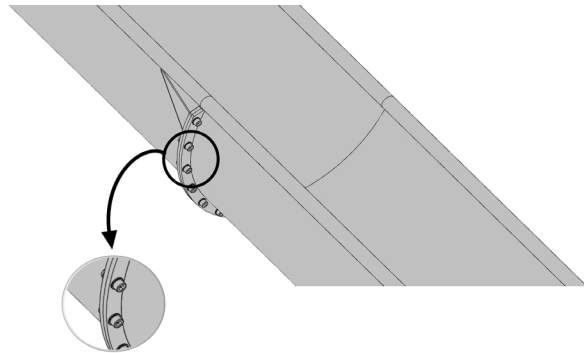

per SC	Total	K&K-Item	Marking
1 x	11 x	3430011	hexagon cap nut M10 DIN986 A2
2 x	22 x	3430014	Washer Ø 10,5 DIN125 form B A2
1 x	11 x	3400162	Cheese head screw M10 x 30 DIN912 A2

**2 x SFAS1070013 Flange connection of hill slide sections**

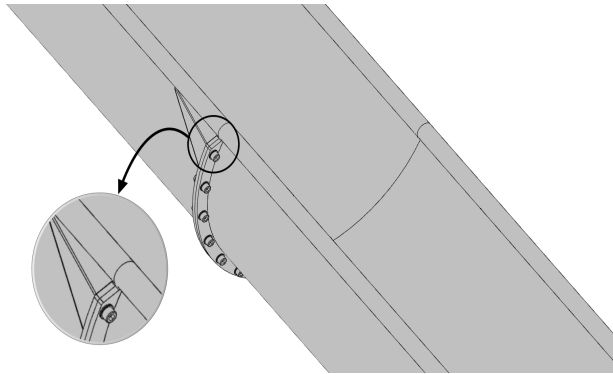

per SC	Total	K&K-Item	Marking
1 x	2 x	3430014	Washer Ø 10,5 DIN125 form B A2
1 x	2 x	3400162	Cheese head screw M10 x 30 DIN912 A2

**36 x SFAS1240029 HPL panel fastening to roof pipe support**

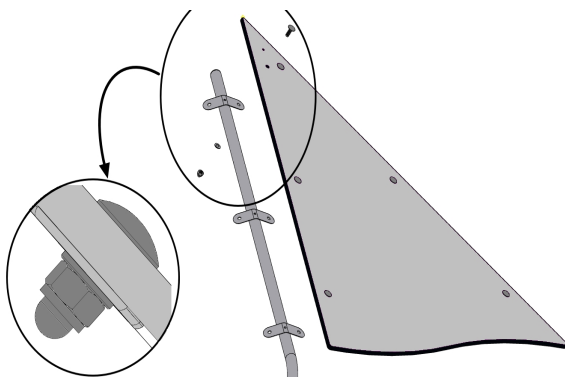

per SC	Total	K&K-Item	Marking
1 x	36 x	3430011	hexagon cap nut M10 DIN986 A2
1 x	36 x	3430014	Washer Ø 10,5 DIN125 form B A2
1 x	36 x	3400138	mushroom head screw square neck M10x30 DIN 60



Item: **041310700**

Order:

1295318

Combi slide

Location:

Building Project:

**3 x SFAS1240032 Roof hood fastening on HPL panels**

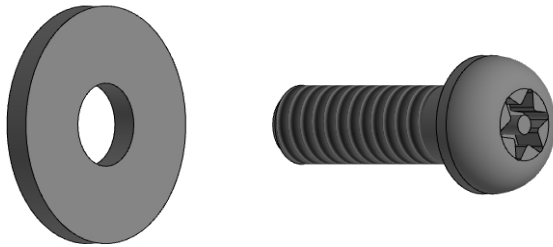

per SC	Total	K&K-Item	Marking
1 x	3 x	3430102	Washer Ø 8.4 DIN9021 A2
1 x	3 x	3400673	Dome head screw M8x20 A2 Security Torx TR40

**1 x SFWZ0000001 Security TORX wrench TR40**



per SC	Total	K&K-Item	Marking
1 x	1 x	3490081	Allen key security TORX TR40

**1 x SFWZ0000005 Allen key security hex socket AF8**



per SC	Total	K&K-Item	Marking
1 x	1 x	3490057	Allen key security hex socket AF8

**1 x SFWZ0000012 Lubricating metal (30 g box) incl. brush**



per SC	Total	K&K-Item	Marking
1 x	1 x	5300039	Lubricating metal box 30g
1 x	1 x	5200026	Brush for lubricating metal

Item: **041310700**

Order:

1295318

Combi slide

Location:

Building Project:

**6 x SFAS1270001 Reinforcing steel bar for posts**

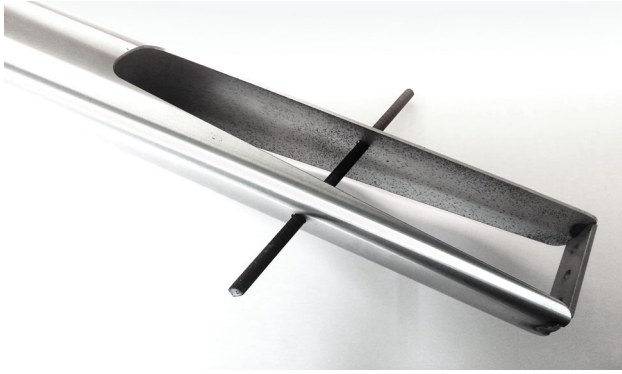

per SC	Total	K&K-Item	Marking
1 x	6 x	2130000	Reinforcing steel Ø 10 x 310 DIN 488