

1. Assign a device location considering the space requirement (impact area).
Due to a possible sliding surface heating, please see to a north-east orientation (northern hemisphere) of the slides or provide half-shade of trees.
For countries in the southern hemisphere, see to a south-east orientation.
2. Excavate soil for foundations, according to drawing.
Please note: To achieve maximum stability and a safe installation, a moderate level of soil solubility is required.
3. Pour in a drain layer of gravel of approx. 10 cm thickness between the bottom of the posts and plain base of foundation.
4. Insert reinforcing steel into the corresponding holes of the posts.
5. Place posts type A according to the corresponding number (see foundation layout) into the respective foundation hole. Play level mark (=aluminium blind rivet) complies with the installation depth. Align every post by means of the play level mark facing into the same direction (see detail or foundation layout).

6. For installation of the pre-assembled components and/or single parts, the screws slightly have to be lubricated with installation paste!

Screw together platforms and posts by using the middle hole in the mounting brackets.

Tighten all screws after having aligned all components.

Install the slide exit with the given inclination in sliding direction so that rain water can drain off (see foundation detail).

Screw connections see details in attached list.

7. Grout foundations with compressed concrete C20/25, chamfer and round off the edges, cover the foundations with a surface which meets the requirement for impact attenuation so that the critical fall height of the surfacing is equal to, or greater than, the free height of fall of the equipment (acc. to EN 1176-1). The run-out section fall zone must have surfacing with a critical fall height of at least 1000mm (acc. to EN 1176-3).
8. Release for play after concrete foundations have set.
9. According to maintenance instructions, check all screw connections after 4-5 weeks and retighten, if necessary.

Please ensure that all special tools supplied (e.g. Allen key for secured Allen screws etc.) and all specific documents which are or may be useful for safety management acc. to EN 1176-7 (e.g. invoice, delivery note, order acknowledgement, installation instructions, maintenance instructions) are forwarded to the persons responsible.

Necessarily insert all attachment parts before tightening the screws. It is NOT possible to insert them afterwards.

Please note: 

Due to the format size, this installation is not to scale (apart from single details).

Please refer to the dimensions indicated.

An installation documentation scale 1:50 can be submitted on request.

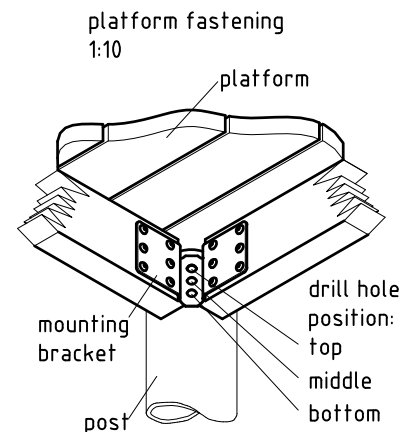

detail of check mark
1:5

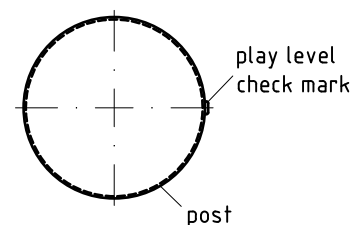

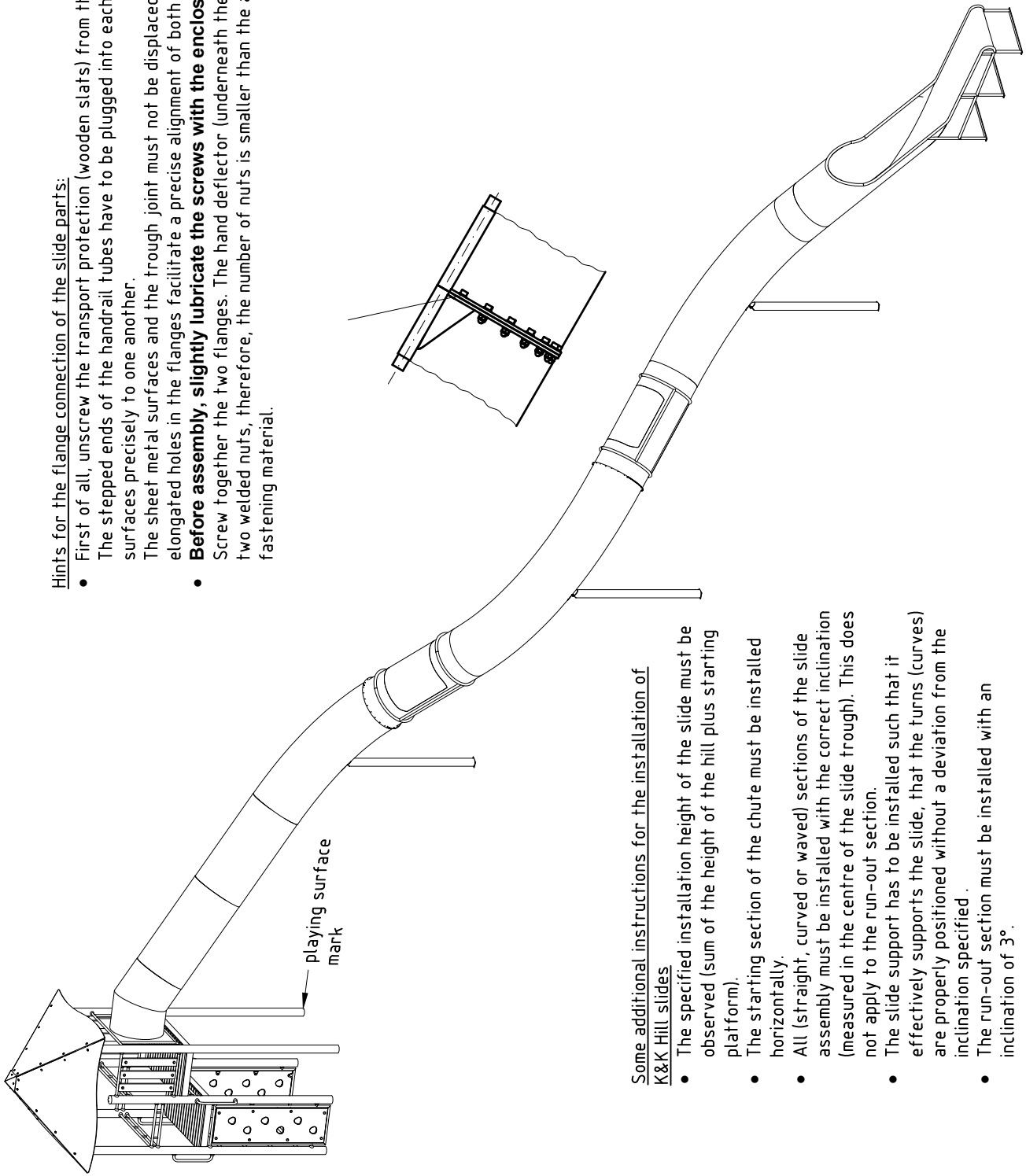

Hints for the flange connection of the slide parts:

- First of all, unscrew the transport protection (wooden slats) from the slide parts.
- The stepped ends of the handrail tubes have to be plugged into each other. Adjust both flange surfaces precisely to one another.
- The sheet metal surfaces and the trough joint must not be displaced against each other. The elongated holes in the flanges facilitate a precise alignment of both slide parts.
- **Before assembly, slightly lubricate the screws with the enclosed installation paste.** Screw together the two flanges. The hand deflector (underneath the handrail) is provided with two welded nuts, therefore, the number of nuts is smaller than the amount of the other fastening material.

Some additional instructions for the installation of K&K Hill slides

- The specified installation height of the slide must be observed (sum of the height of the hill plus starting platform).
- The starting section of the chute must be installed horizontally.
- All (straight, curved or waved) sections of the slide assembly must be installed with the correct inclination (measured in the centre of the slide trough). This does not apply to the run-out section.
- The slide support has to be installed such that it effectively supports the slide, that the turns (curves) are properly positioned without a deviation from the inclination specified.
- The run-out section must be installed with an inclination of 3°.

- Due to forced movement, the entire impact area must have impact attenuating surfacing. The critical fall height of the surfacing shall be equal to, or greater than, the free height of fall of the equipment (see EN 1176-1). Depending on the site profile, the free fall height (hx) and the size of the impact area result from the vertical distance between the bottom of the chute and ground level
- The surfacing material for the impact area within the sliding section must meet the requirements given in table 4 (see EN 1176-1). The shock-absorbing characteristics of any other material to be chosen must be certified in accordance with EN 1177.
- The surface around the run-out section shall have a critical fall height of at least 1000mm and shall be provided to at least 2000 mm beyond the run-out section (acc. to EN 1176-3).

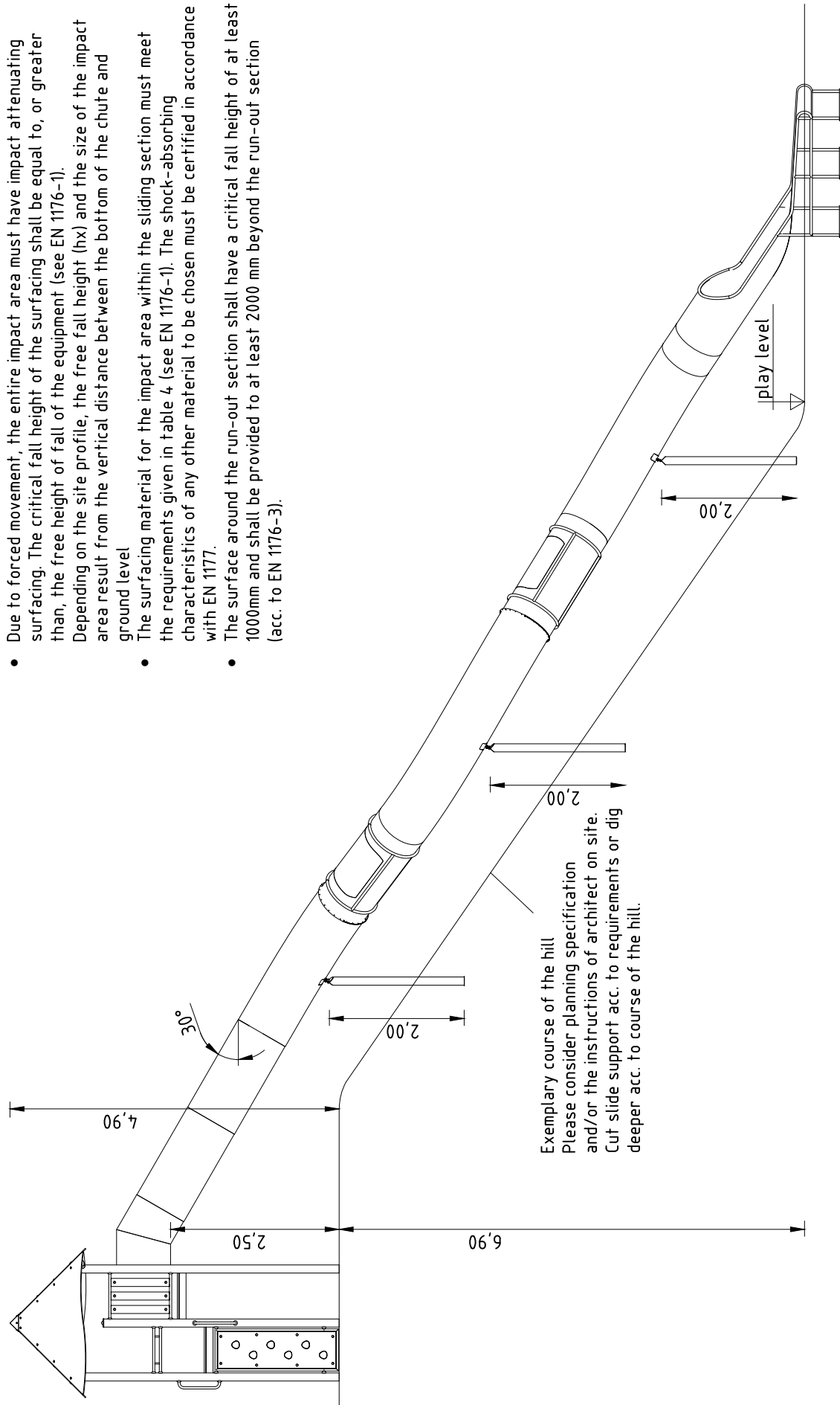

Plug-in base for slide support
1:20
 to be mounted as follows:
 If necessary, shorten stainless steel slide support to the required length (with adequate appliance e.g. angle grinder).
 Insert base from below into the stainless steel post.

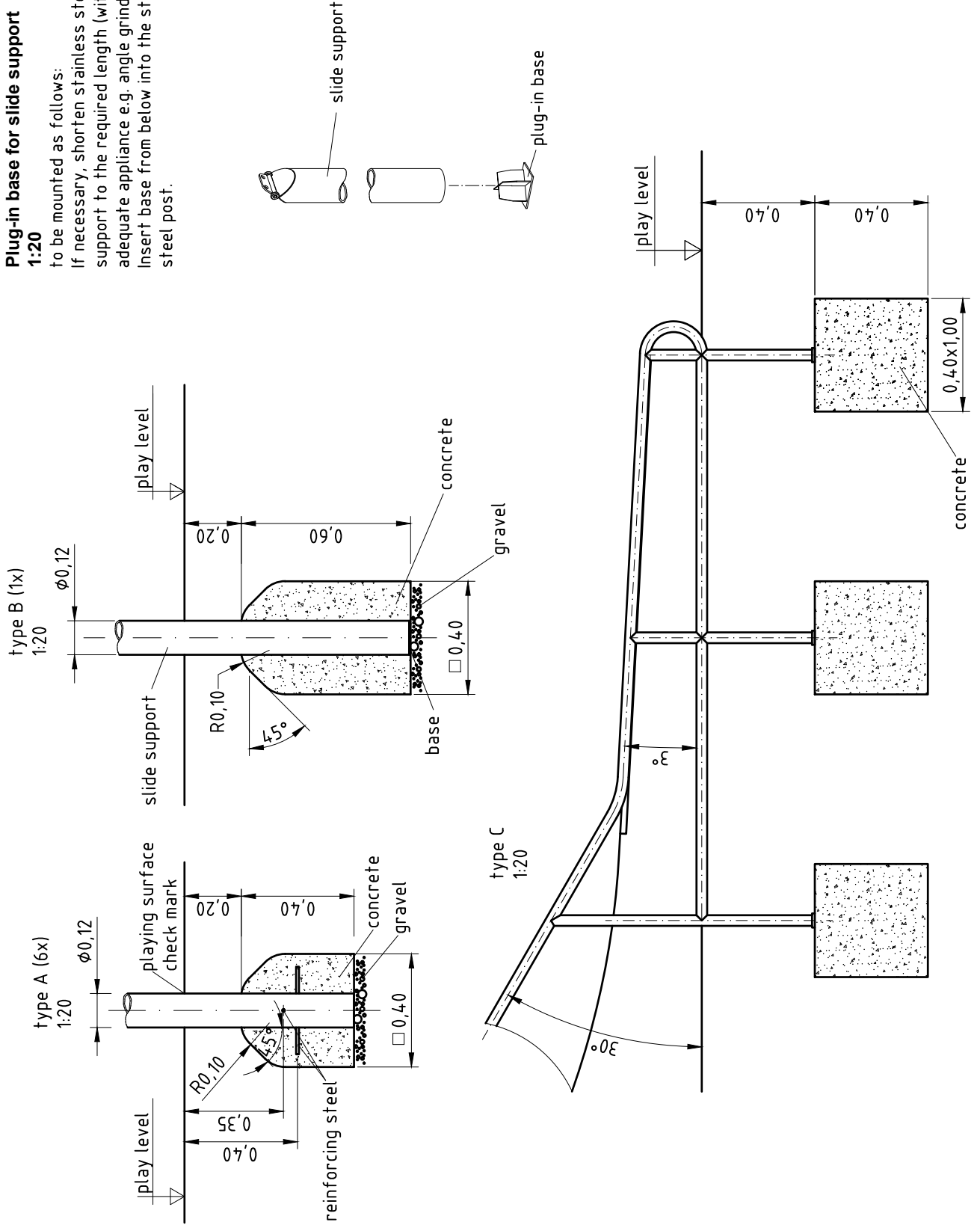

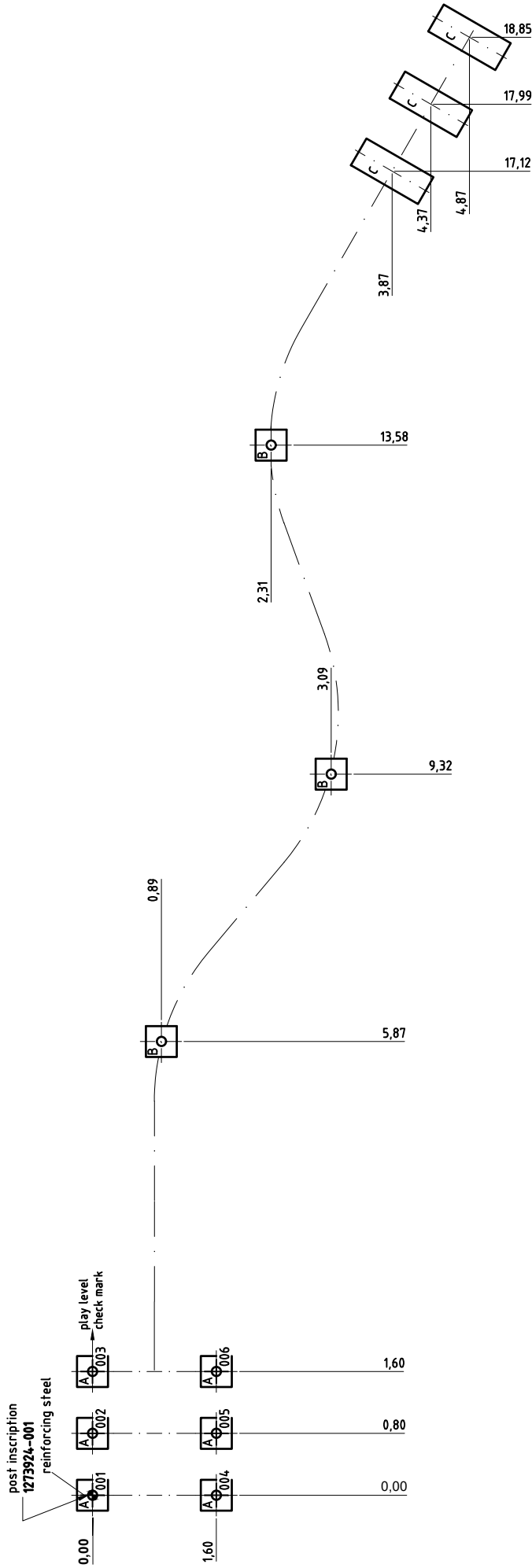

Installation

Item-No.
0-41330-500
0-41330-700

Description
Combi slide

Scale
-

Date
07/23 EB

Page
5/6

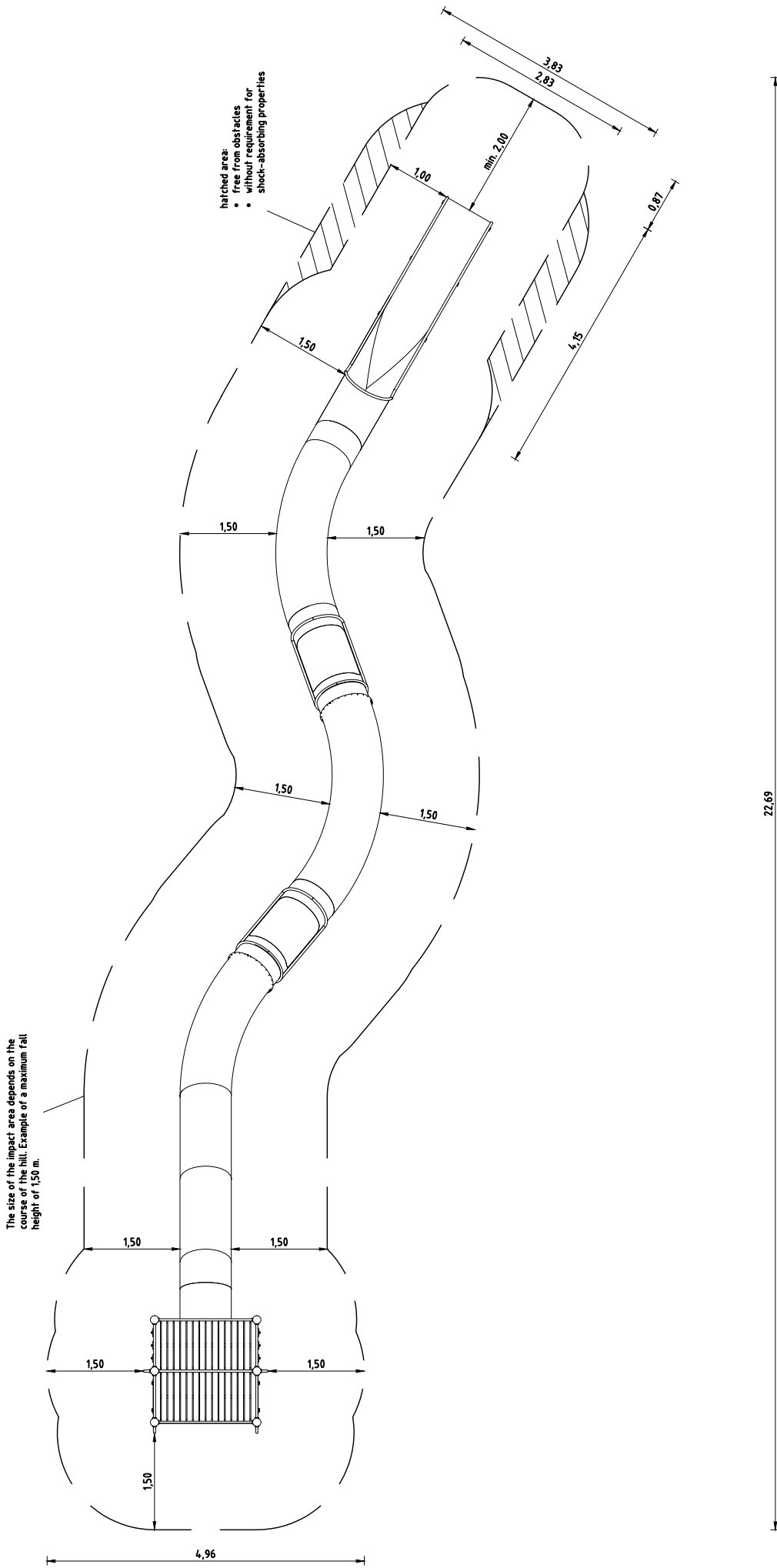

Installation

Item-No.
0-41330-500
0-41330-700

Description
Combi slide

Scale
-

Date
07/23 EB

Page
6/6

Item: **041300500**
Slide tower (3,90)

Order:

1297228

Location:

Building Project:

8 x SFES1200001 Platform fastening to stainless steel post, nut on the side of the platform

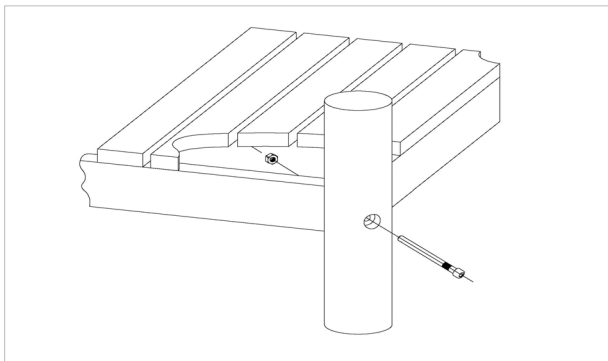

per set	total	item no.	material short text
1 x	8 x	3430021	Lock nut M12 DIN985 A2
1 x	8 x	2030651	Cheese head screw with pin M12 x 125

66 x SFES1210001 Standard bolting of attachment parts (except platforms) to stainless steel posts

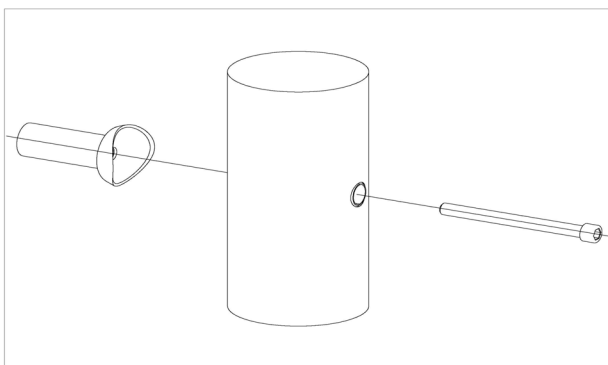

per set	total	item no.	material short text
1 x	66 x	2030168	Cheese head screw with pin M12x140

32 x SFAS1240029 HPL panel fastening to roof pipe support

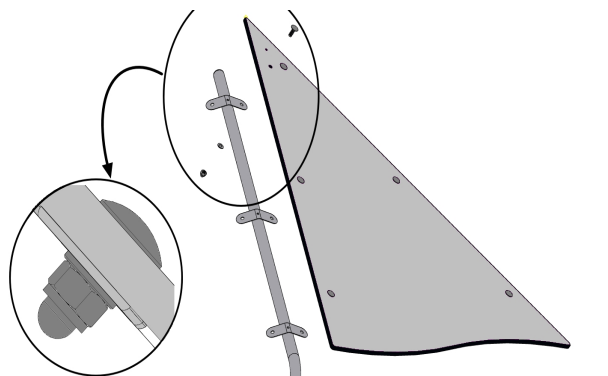

per set	total	item no.	material short text
1 x	32 x	3430011	hexagon cap nut M10 DIN986 A2
1 x	32 x	3430014	washer Ø 10,5 DIN125 form B A2
1 x	32 x	3400138	mushroom head screw square neck M10x30 DIN 60

4 x SFAS1240032 Roof hood fastening on HPL panels

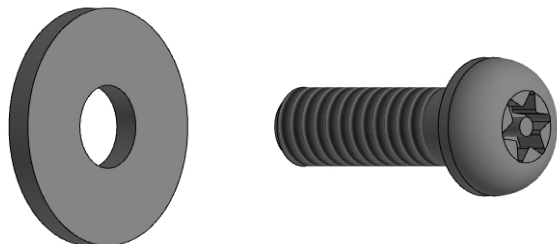

per set	total	item no.	material short text
1 x	4 x	3430102	Washer Ø 8.4 DIN9021 A2
1 x	4 x	3400673	Dome head screw M8x20 A2 Security Torx TR40

Item: **041300500**
Slide tower (3,90)

Order:

1297228

Location:

Building Project:

6 x SFAS1070004 Slide support post below hill slide

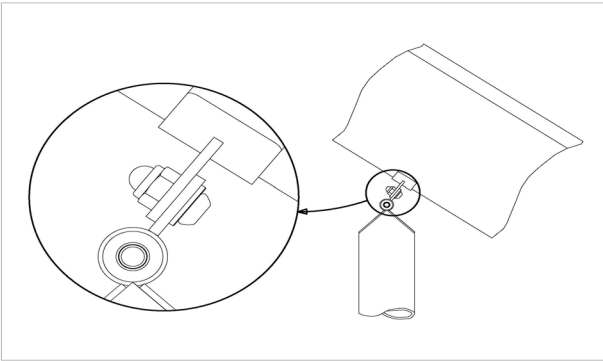

per set	total	item no.	material short text
1 x	6 x	3430025	washer Ø 13 DIN125 A2
1 x	6 x	3400622	Dome head security bolt M12x25 PinHexagon A2 safety coated thread

48 x SFAS1070014 Flange connection of tunnel slide sections

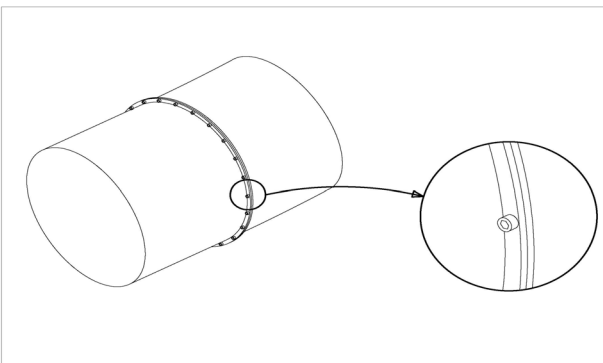

per set	total	item no.	material short text
1 x	48 x	3430014	washer Ø 10,5 DIN125 form B A2
1 x	48 x	3430011	hexagon cap nut M10 DIN986 A2
1 x	48 x	3400162	Cheese head screw M10 x 30 DIN912 A2

6 x SFXS1070011 (Short) Tunnel slide run-out section stone bolt assembly

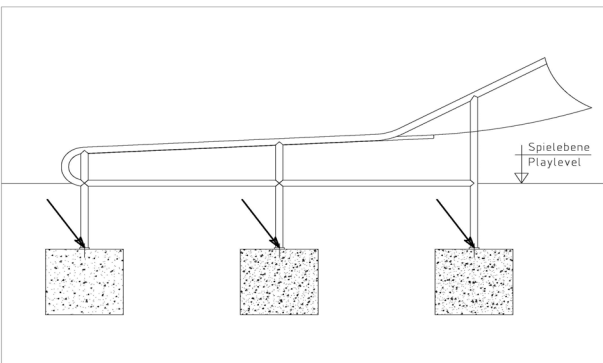

per set	total	item no.	material short text
1 x	6 x	1070365	Set of stone bolts for slide run-out section M12x160

12 x SFAS1270001 reinforcing steel bar for posts

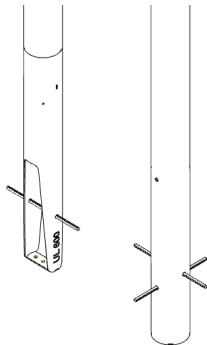

per set	total	item no.	material short text
1 x	12 x	2130000	reinforcing steel Ø 10 x 310 DIN 488

Item: **041300500**
Slide tower (3,90)

Order:

1297228

Location:

Building Project:

1 x SFWZ0000009 Hexagon insert socket driver 10mm 1/2" with borehole for Pin



per set	total	item no.	material short text
1 x	1 x	2030170	Hexagon insert socket driver 10 mm 1/2" with drill hole for Pin

1 x SFWZ0000012 lubricating metal (30 g box) incl. brush



per set	total	item no.	material short text
1 x	1 x	5300039	lubricating metal box 30g
1 x	1 x	5200026	brush for lubricating metal

1 x SFWZ0000005 Allen key security hex socket AF8



per set	total	item no.	material short text
1 x	1 x	3490057	Allen key security hex socket AF8