

cheese-head screw
DIN 912/ISO 4762-
M8x20-A2

1. Assign a location for the equipment considering the (minimum) space requirements/impact area.
2. Excavate soil for foundations, according to drawing. Please note: To achieve maximum stability and a safe installation, a moderate level of soil solubility is required.
3. Screw together the single components of the equipment (swing crossbeam and posts).
Before fastening the prefabricated parts, slightly lubricate the screws with installation paste!
4. Mount the reinforcement meshes to the steel posts. Attach a support tube to each post and fix both parts by a quarter-turn of the tube. Put assembled equipment into foundation holes and align it. If necessary, support it temporarily, in accordance with all security-relevant rules.
5. Grout foundations with compressed concrete C20/25 and ensure a concrete coverage of the reinforcement meshes of at least 5 cm. Cover with a surfacing material which meets the requirements for impact attenuation so that the critical fall height of the surfacing shall be equal to, or greater than, the free height of fall (acc. to EN 1176-1).
6. After concrete foundations have set, attach chains to chain adapters in swing axles: unscrew cheese-head screw (M8x20-A2) inside adapter, insert the last chain link and fix it with the screw. Please note that the cheese-head screw slightly has to be lubricated with the installation paste supplied and tightened stoutly e.g. with an Allen key or a catch without overwinding.
7. If necessary, shorten length of chain in order to ensure ground clearance of at least 0,45 m.
8. According to maintenance instructions, check all screw connections after 4-5 weeks and retighten, if necessary.

Please ensure that all special tools supplied (e.g. Allen key for secured Allen screws etc.) and all specific documents which are or may be useful for safety management acc. to EN 1176-7 (e.g. invoice, delivery note, order acknowledgement, installation instructions, maintenance instructions) are forwarded to the persons responsible.

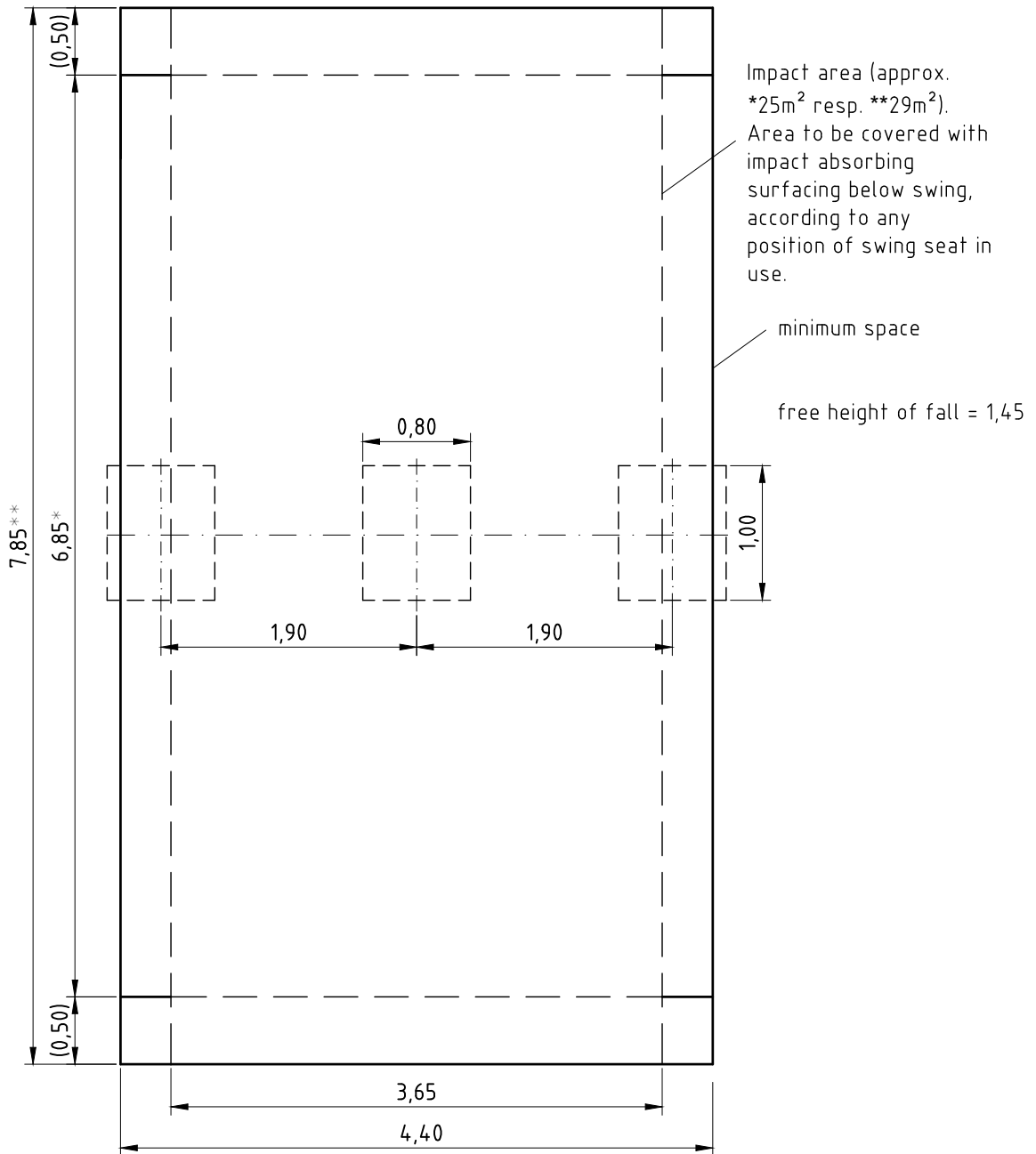
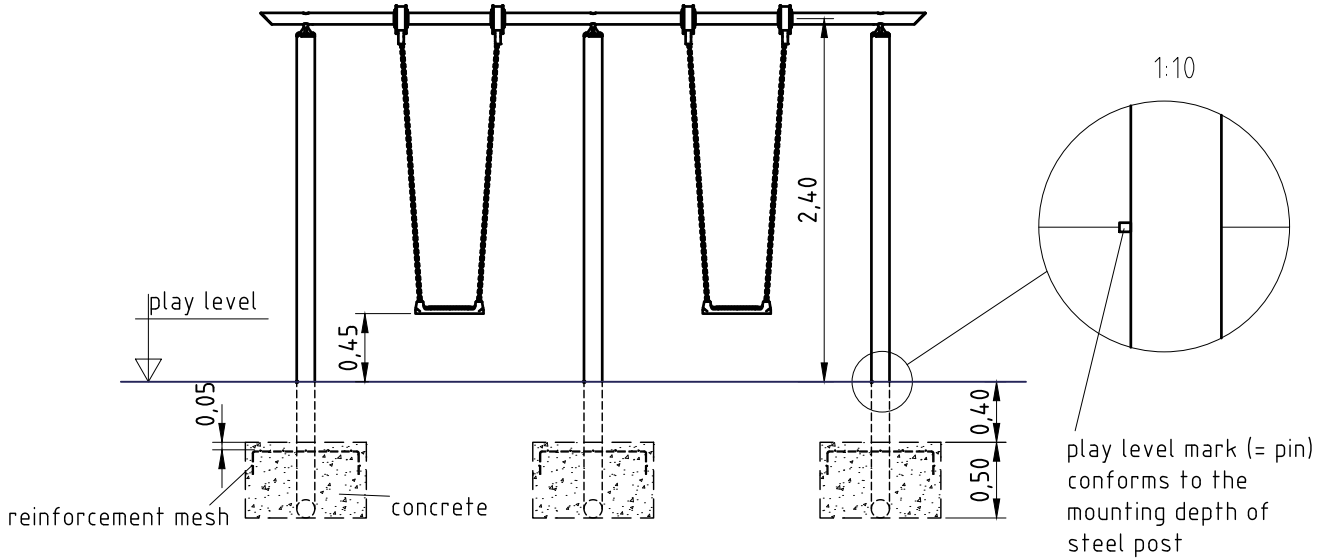

*) measure for synthetic surfacing with impact absorbing effect that is level with the surrounding area (cf. EN 1176-2:2008). In swinging direction, there shall be an additional area of 0,50m length free from obstacles.

***) measure for natural surfacing with impact absorbing effect, normally loose fill (cf. EN 1176-2).

