

\*) measure for synthetic surfacing with impact attenuating effect, level with the surrounding area. In swinging direction, an additional area of 0,50m length free from obstacles must be provided (cf. EN 1176-2:2008; 4.10.2.1).

\*\*\*) measure for natural surface with impact attenuating effect, normally loose

**Please note:**

Due to the format size, this installation is not to scale (apart from single details).

Please refer to the dimensions indicated.

An installation documentation scale 1:50 can be submitted on request.

Cheese-head screw  
DIN 912/ISO 4762-M8x20-A2

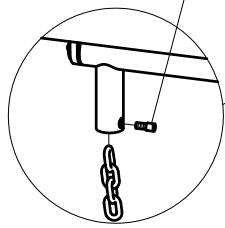

4 x screw connection:  
1 x hexagon head bolt  
DIN 933-M16x55-A2  
2 x washer DIN 125- $\phi$ 17-A2  
1 x cap nut DIN 986-M16-A2

8 x screw connection:  
1 x hexagon head bolt  
DIN 933-M16x45-A2  
2 x washer DIN 125- $\phi$ 17-A2  
1 x cap nut DIN 986-M16-A2

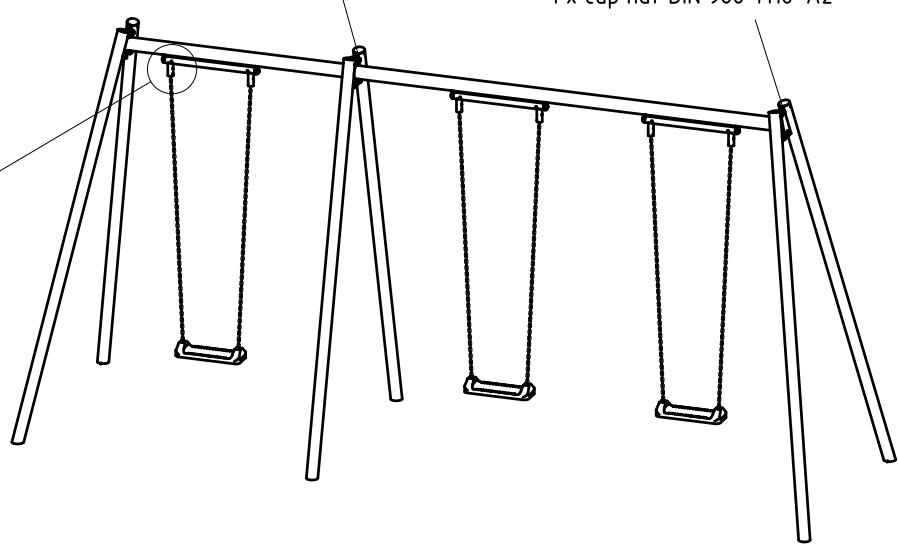

Foundation:  
Type A  
scale 1:20

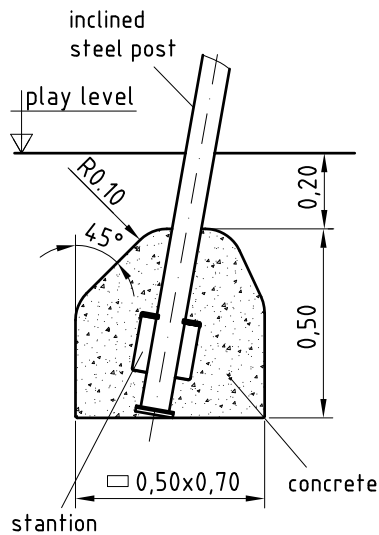

Foundation:  
Type B  
scale 1:20

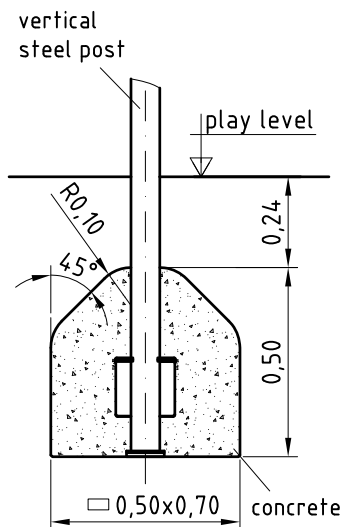

1. Assign location of equipment considering the minimum space requirement (impact area).
2. Excavate soil for foundations, according to drawing. Please note: To achieve maximum stability and a safe installation, a moderate level of soil solubility is required.
3. **Attention: Before fastening the posts to the swing crossbeam, slightly lubricate the screws with installation paste!**
4. Screw steel posts to crossbeam according to drawing, put assembled equipment into foundation holes and align it.
5. Grout foundations with compressed concrete C20/25, chamfer and round off the edges and cover with a surface which meets the requirements for impact attenuation so that the critical fall height of the surfacing shall be equal to, or greater than, the free height of fall (acc. to EN 1176-1).
6. After concrete foundations have set, attach chains to chain adapters in swing axle: unscrew cheese-head screw (M8x20) inside adapter, insert the last chain link and fix it with the screw. Attention: the cheese-head screw slightly has to be lubricated with installation paste! Please note that the cheese-head screw has to be tightened stoutly e.g. with an Allen key or a catch without overwinding the screw. If necessary, shorten length of chain in order to ensure recommended ground clearance of 0,45 m below swing seat.
7. According to maintenance instructions, check all screw connections after 4-5 weeks and retighten, if necessary.

Please ensure that all special tools (e.g. Allen key for secured Allen screws etc.) and all specific documents which are or may be useful for safety management acc. to EN 1176-7 (e.g. invoice, delivery note, order acknowledgement, installation instructions, maintenance instructions) are forwarded to the persons responsible .