

1. Assign location of equipment considering the space (falling space) requirement.
2. Excavate soil for foundations, according to drawing.
Please note: To achieve a maximum of stability and a safe installation a normal level of soil solubility is required
3. Grout in foundation with compressed concrete C20/25, insert flange ring into concrete according to drawing and align with spirit level.
4. Screw up steel post onto flange ring after concrete foundations have set.
Cover foundation with surface which shall meet the requirements for impact attenuation so that the critical height of the surfacing according to EN 1177 shall be equal or greater than the free height of fall of the equipment (acc. to EN 1176-1).
5. Screw up scale-crossbeam to post.
REQUIRED TOOL: Torque spanner for torque 95 Nm
6. Screw up pendulum seats to universal joints
Unscrew cheese-head screw (M8x20) inside adapter, insert last chain link and fix with screw. Please note that the cheese-head screw has to be tightened e.g. with allen key or catch stoutly without overwinding the screw.
If necessary, cut length of chain in order to ensure minimum ground clearance of 0.70 m (cut the chain only above the grip / see detail page 2).
7. Check all screw connections acc. to maintenance instructions after 4-5 weeks and screw down again if necessary.

Please take care that all special tools (e.g. special Allen key for secured Allen screws etc.) and all specific documents which are or may be useful for safety management acc. to EN 1176-7 (e.g. invoice, delivery note, order acknowledgement, installation instructions, maintenance instructions) are forwarded to the responsible persons.

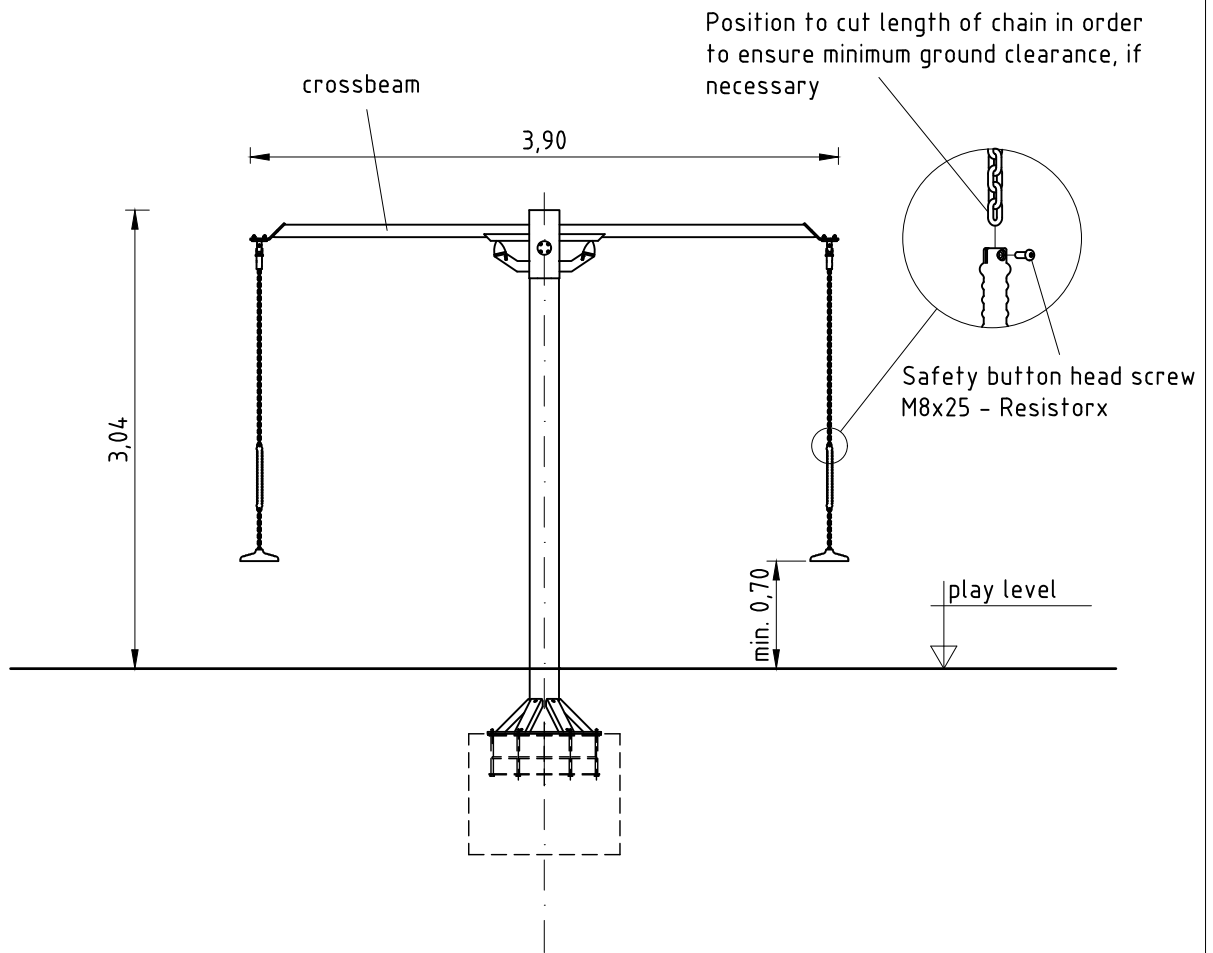

Scale 1:100

