

total height of the equipment

EN 1176

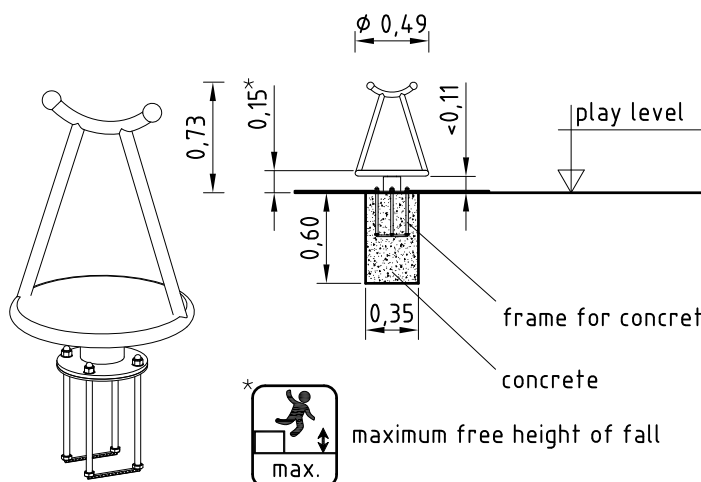

4x screw connection:  
 hexagon cap nut DIN 986-M16, zinc-coated;  
 washer DIN 125-17, zinc-coated

detail 1:20

shock-absorbing surfacing

play level

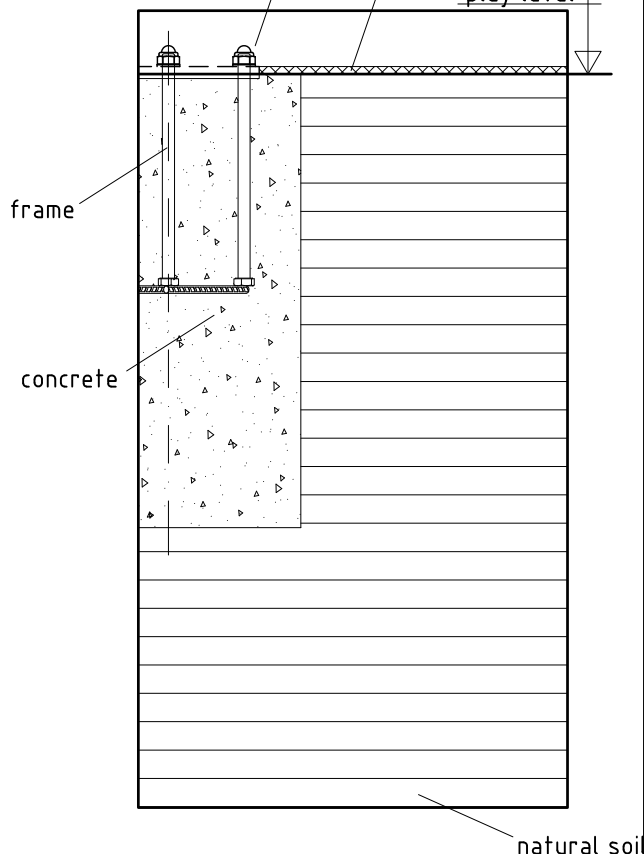

impact area  
 (shock-absorbing surfacing essential)

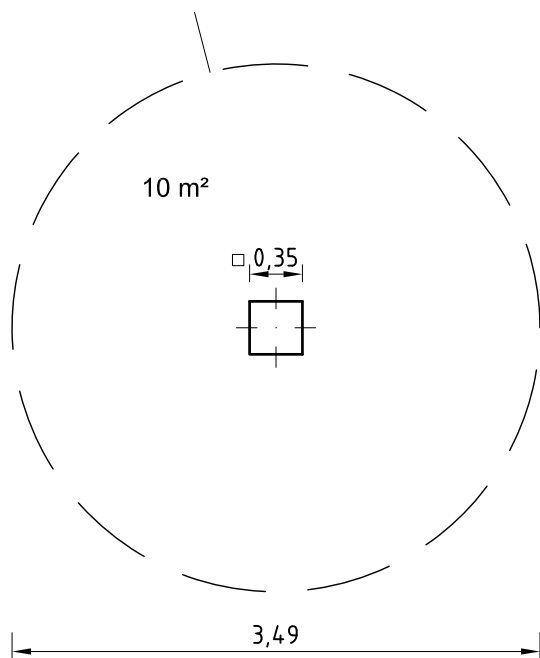

1. Assign a location for the equipment considering the (minimum) space requirements.
2. Excavate soil for foundation, according to drawing.  
Please note: To achieve maximum stability and a safe installation, a moderate level of soil solubility is required.
3. Grout foundation with compressed concrete C20/25, insert depth anchorage into concrete according to drawing and align it with a spirit level.
4. The soil characteristics of the impact area surrounding the equipment must have an appropriate level of shock absorption corresponding to a free height of fall of at least 600 mm (according to EN 1176-5).
5. After concrete foundation has set, fix equipment to depth anchorage in the following order:  
Flange of bearing - washer - self-locking nut M16.
6. According to maintenance instructions, check all screw connections after 4-5 weeks and retighten, if necessary.

Please take care that all special tools (e.g. Allen key for secured Allen screws etc.) and all specific documents which are or may be useful for safety management acc. to EN 1176-7 (e.g. invoice, delivery note, order acknowledgement, installation instructions, maintenance instructions) are forwarded to the responsible persons.