

1. Assign a device location considering the space requirement (impact area). Slide direction recommended: north-east or in half-shade of trees.
2. Excavate soil for foundations, according to drawing.
Please note: To achieve maximum stability and a safe installation, a moderate level of soil solubility is required.
3. Pour in a drain layer of gravel of approx. 10 cm thickness between the bottom of the posts and plain base of foundation.
4. Insert reinforcing steel into the corresponding holes of the posts.
5. Place posts type A according to the corresponding number (see foundation layout) into the respective foundation hole. Play level mark (=aluminium blind rivet) complies with the installation depth. Align every post by means of the play level mark facing into the same direction (see detail or foundation layout).
6. **For installation of the pre-assembled components and/or single parts, the screws slightly have to be lubricated with installation paste!**
Screw together platform and posts by using the middle hole in the mounting brackets.
Tighten all screws after having aligned all components.
Install the slide exit with an inclination of 5° in sliding direction.
Screw connections see details in attached list.
7. Grout foundations with compressed concrete C20/25, chamfer and round off the edges, cover the foundations with a surface which meets the requirements for impact attenuation so that the critical fall height of the surfacing is equal to, or greater than, the free height of fall of the equipment (acc. to EN 1176-1). The run-out section fall zone must have surfacing with a critical fall height of at least 1000mm (acc. to EN 1176-3).
8. Release for play after concrete foundations have set.
9. According to maintenance instructions, check all screw connections after 4-5 weeks and retighten, if necessary.

Please ensure that all special tools supplied (e.g. Allen key for secured Allen screws etc.) and all specific documents which are or may be useful for safety management acc. to EN 1176-7 (e.g. invoice, delivery note, order acknowledgement, installation instructions, maintenance instructions) are forwarded to the persons responsible.

Necessarily insert all attachment parts before tightening the screws. It is NOT possible to insert them afterwards.

platform orientation
1:100

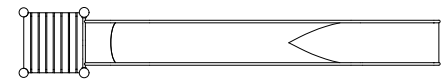

detail of play level mark
1:5

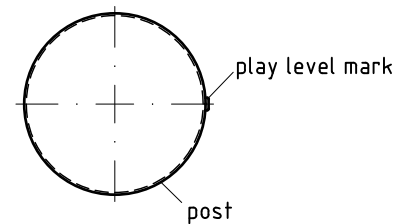

platform fastening
1:10

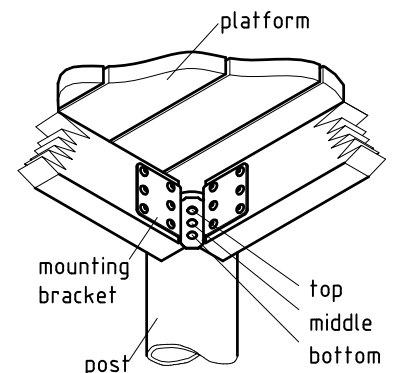

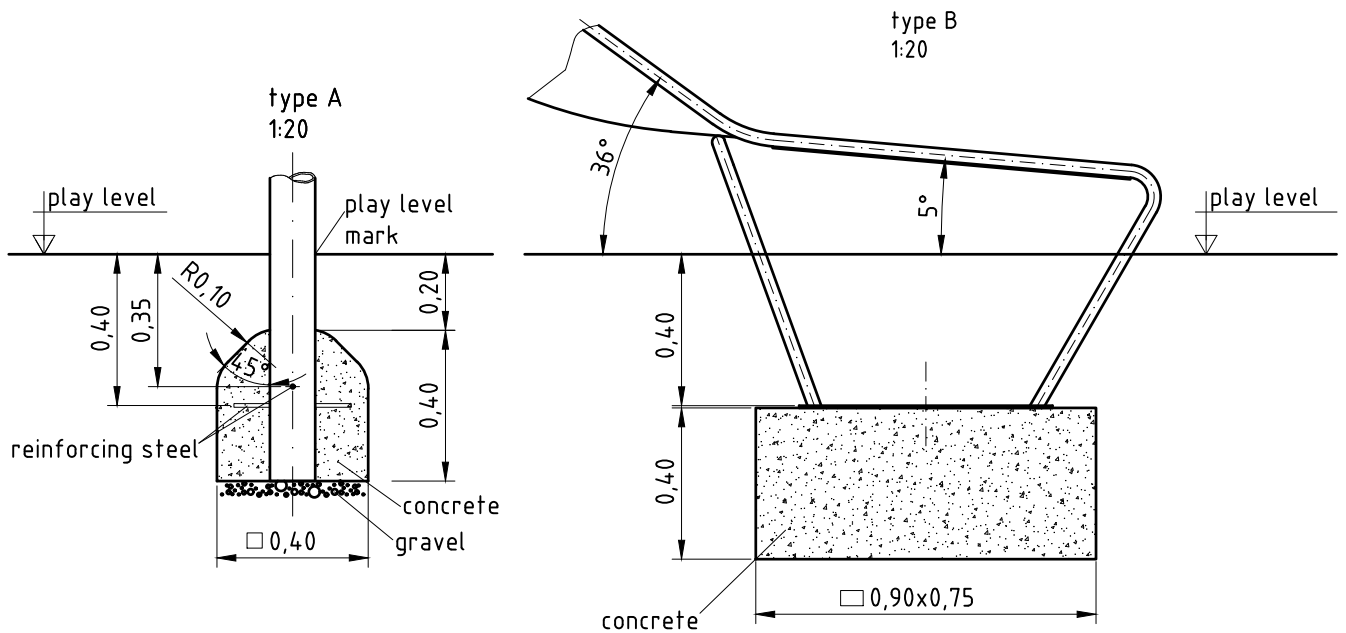
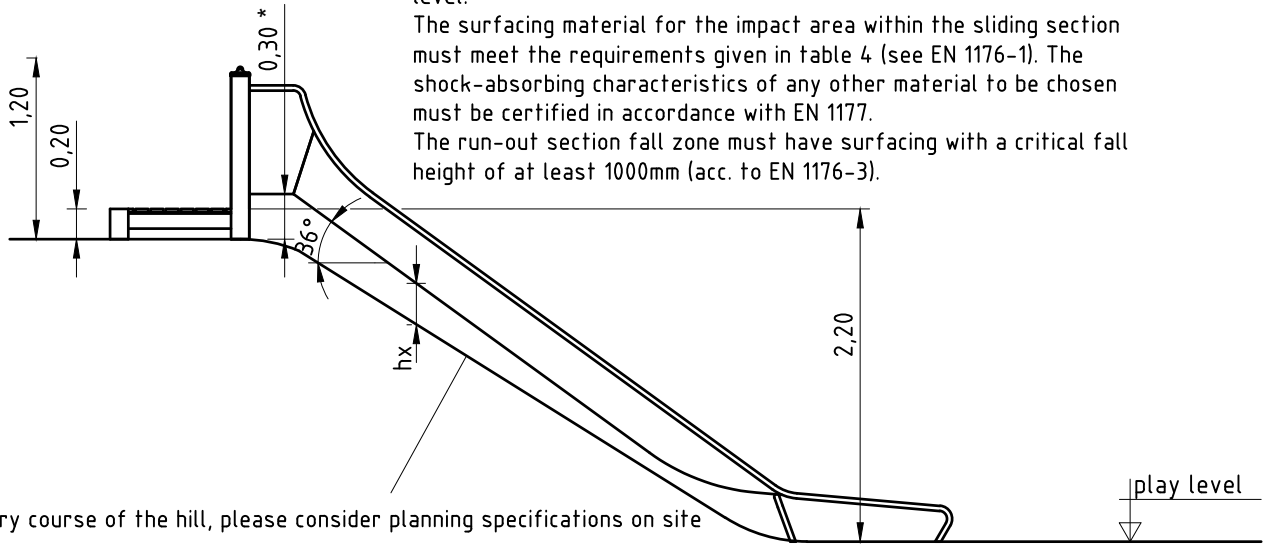

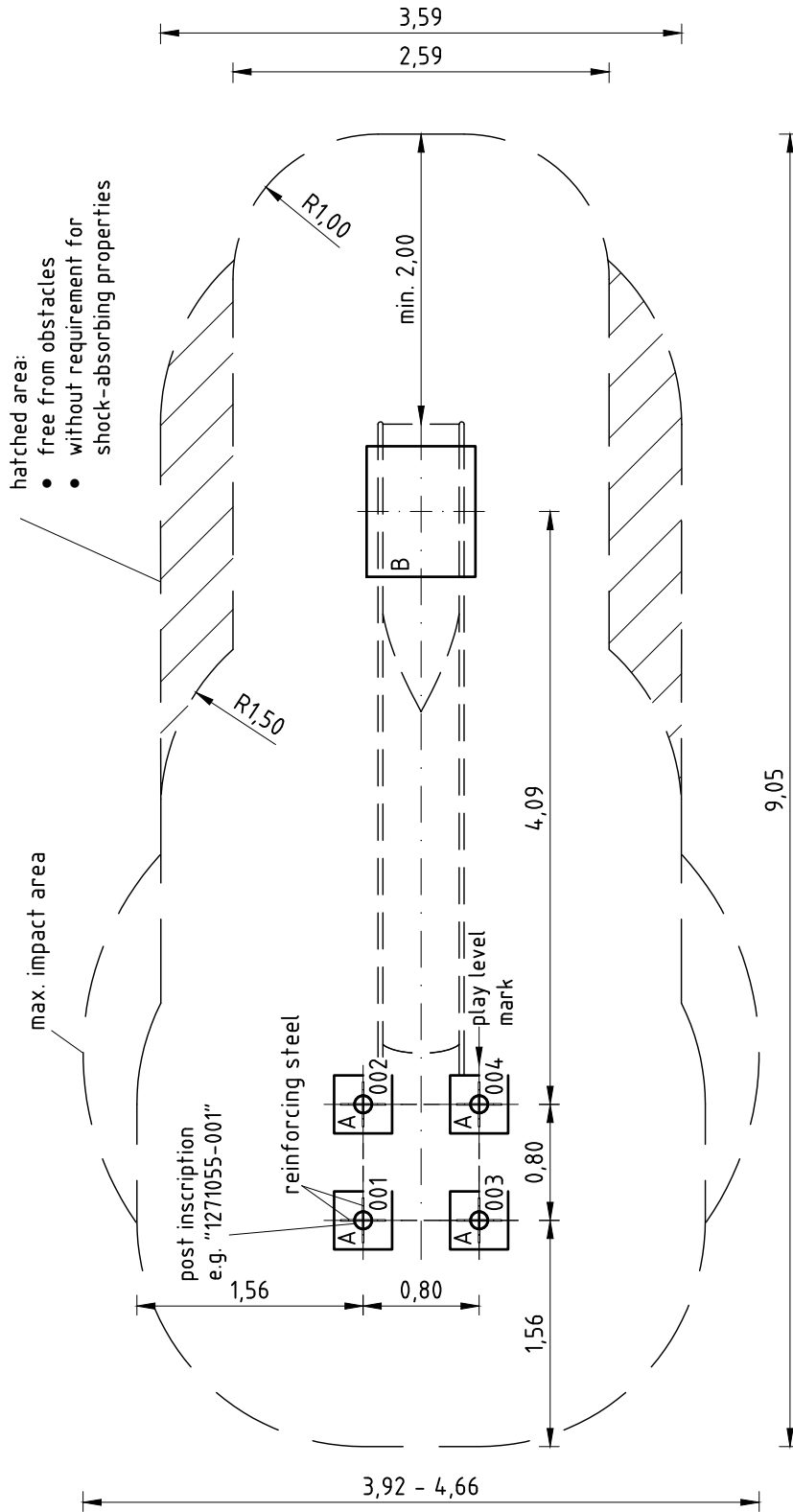

Item: **041822501**

Order:

1293252

Hill slide (2,20) with starting platform 0,20

Location:

Building Project:

4 x SFES120001 Platform fastening to stainless steel post, nut on the side of the platform

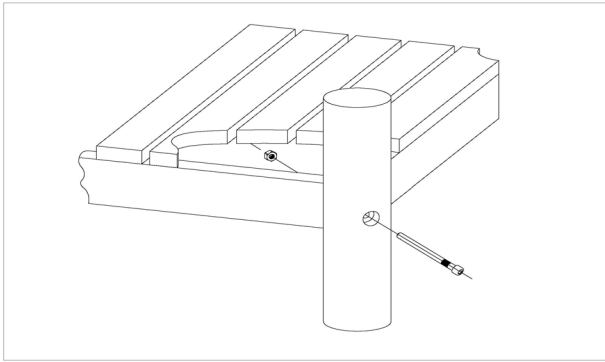

per SC	Total	K&K-Item	Marking
1 x	4 x	3430021	Lock nut M12 DIN985 A2
1 x	4 x	2030651	Cheese head screw with pin M12 x 125

4 x SFES1210001 Standard bolting of attachment parts (except platforms) to stainless steel posts

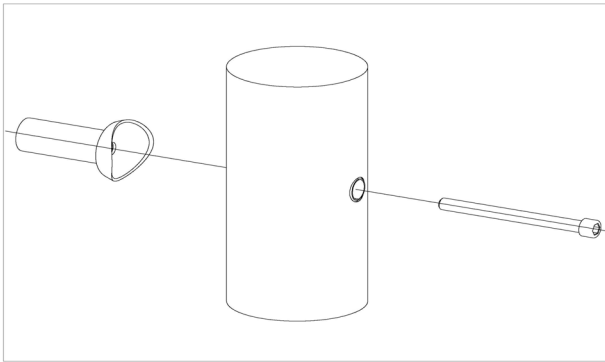

per SC	Total	K&K-Item	Marking
1 x	4 x	2030168	Cheese head screw with pin M12x140

4 x SFES1270001 Reinforcing steel for stainless steel posts



per SC	Total	K&K-Item	Marking
2 x	8 x	2130000	Reinforcing steel Ø 10 x 310 DIN 488

1 x SFXS1070007 Slide run-out section (mini) stone bolt assembly

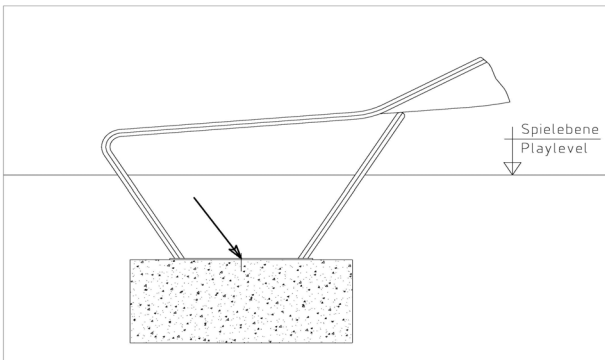

per SC	Total	K&K-Item	Marking
2 x	2 x	1070365	Set of stone bolts for slide run-out section M12x160

Item: **041822501**

Order:

1293252

Hill slide (2,20) with starting platform 0,20

Location:

Building Project:

1 x SFWZ000009 Hexagon insert socket driver 10mm 1/2" with borehole for Pin



per SC	Total	K&K-Item	Marking
1 x	1 x	2030170	Hexagon insert socket driver 10 mm 1/2" with drill hole for Pin

1 x SFWZ000014 Lubricating metal, bag (4 g)



per SC	Total	K&K-Item	Marking
1 x	1 x	5300024	Metaflux fitting lubricant 2x4 g