

platform orientation/numbers
1:100platform fastening
1:10

chart platform fastening

platform-nr.	fastening hole		
	top	middle	bottom
1			x
2	x		
3			x
4	x		
5			x
6	x		
7			x

play level mark
1:5

- Assign a device location considering the space requirement (impact area).
Slide direction recommended: north-east or in half-shade of trees.
- Excavate soil for foundations, according to drawing. Please note: To achieve maximum stability and a safe installation, a moderate level of soil solubility is required.
- Pour in a drain layer of gravel of approx. 10 cm thickness between the bottom of the steel post and plain base of foundation.
- Insert reinforcing steel into the corresponding holes of the steel posts.
- Place posts type A (see foundation layout) according to the corresponding number into the respective foundation hole. Play level mark (=aluminium blind rivet) complies with the installation depth. Align every post by means of the play level mark facing into the same direction (see detail or foundation layout).
- For installation of the pre-assembled components and/or single parts, the screws slightly have to be lubricated with installation paste!**
Screw together platforms and posts by using the respective hole in the mounting brackets (according to chart).
Tighten all screws after having aligned all components.
Install the slide exit with an inclination of 5° in sliding direction.
Screw connections see details in list of screw cases attached.
- Grout foundations with compressed concrete C20/25, chamfer and round off the edges, cover the foundations with a surface which meets the requirements for impact attenuation so that the critical fall height of the surfacing is equal to, or greater than, the free height of fall of the equipment (acc. to EN 1176-1). The run-out section fall zone must have surfacing with a critical fall height of at least 1000mm (acc. to EN 1176-3).
- Release for play after concrete foundations have set.
- According to maintenance instructions, check all screw connections after 4-5 weeks and retighten, if necessary.

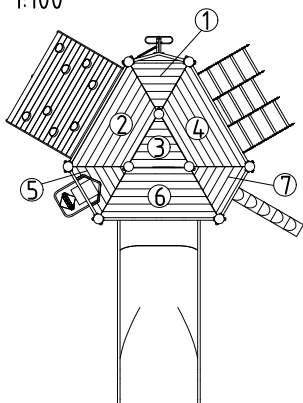
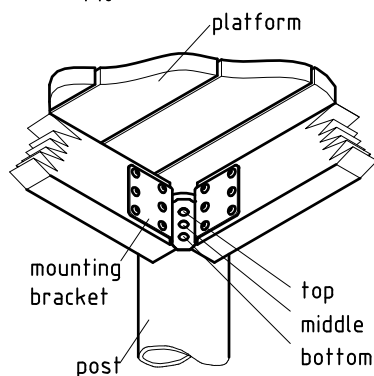
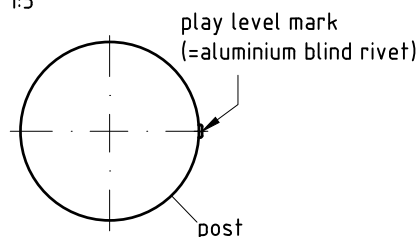
Please ensure that all special tools supplied (e.g. Allen key for secured Allen screws etc.) and all specific documents which are or may be useful for safety management acc. to EN 1176-7 (e.g. invoice, delivery note, order acknowledgement, installation instructions, maintenance instructions) are forwarded to the persons responsible.

**Necessarily insert all attachment parts before tightening the screws.
It is NOT possible to insert them afterwards.**

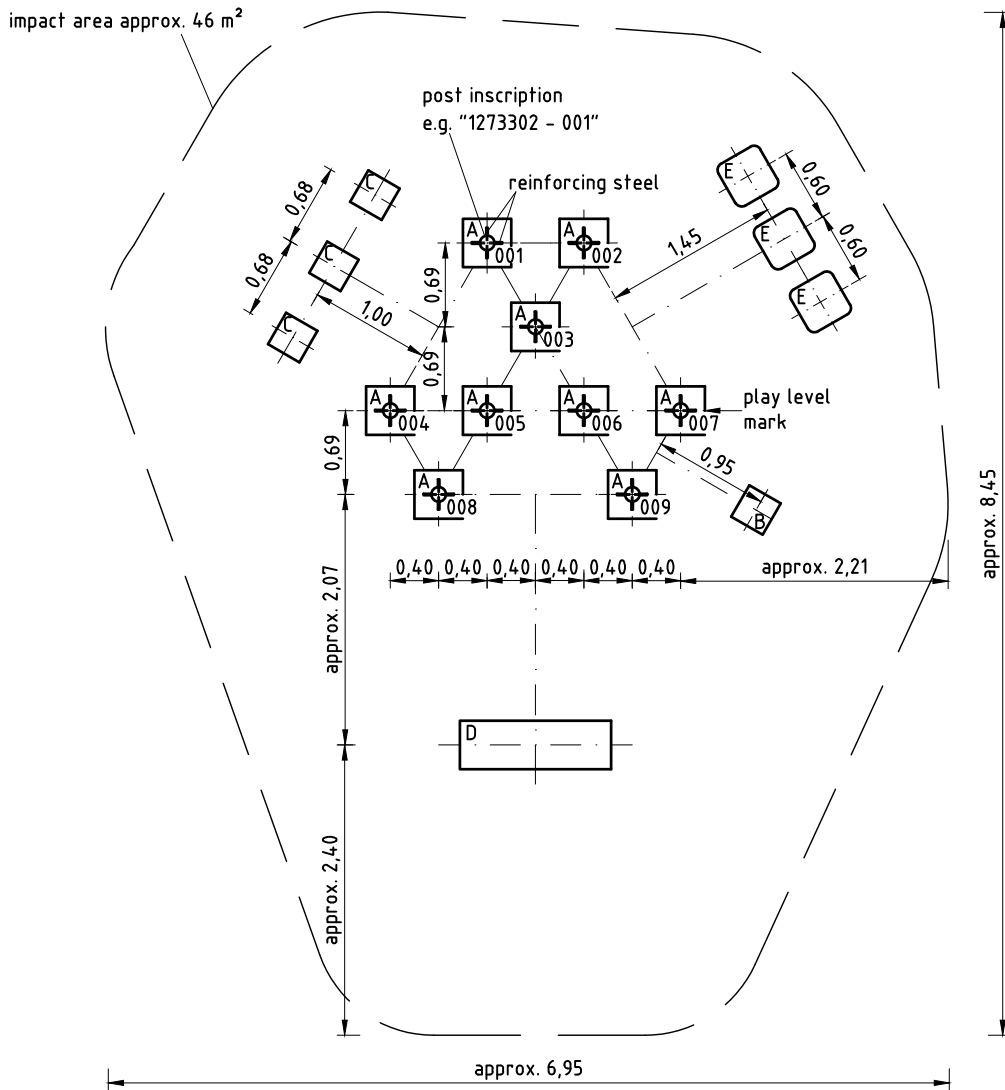
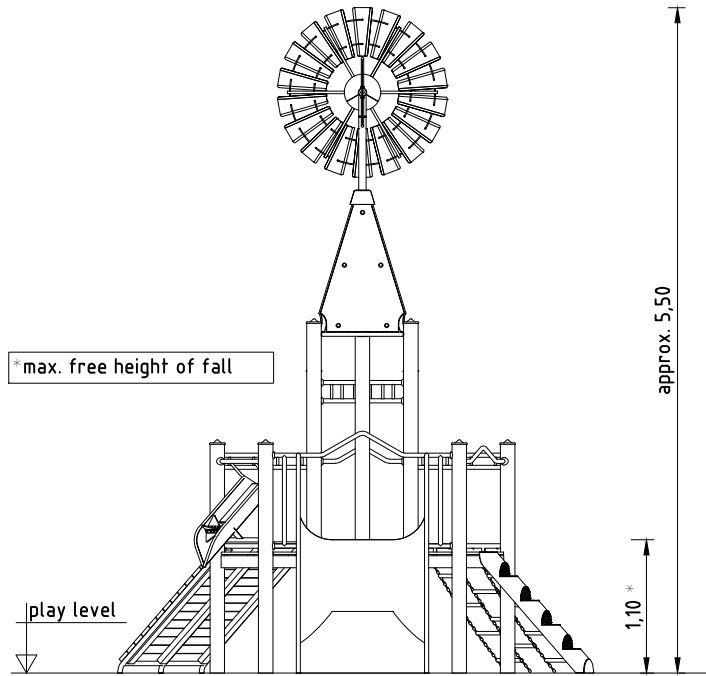

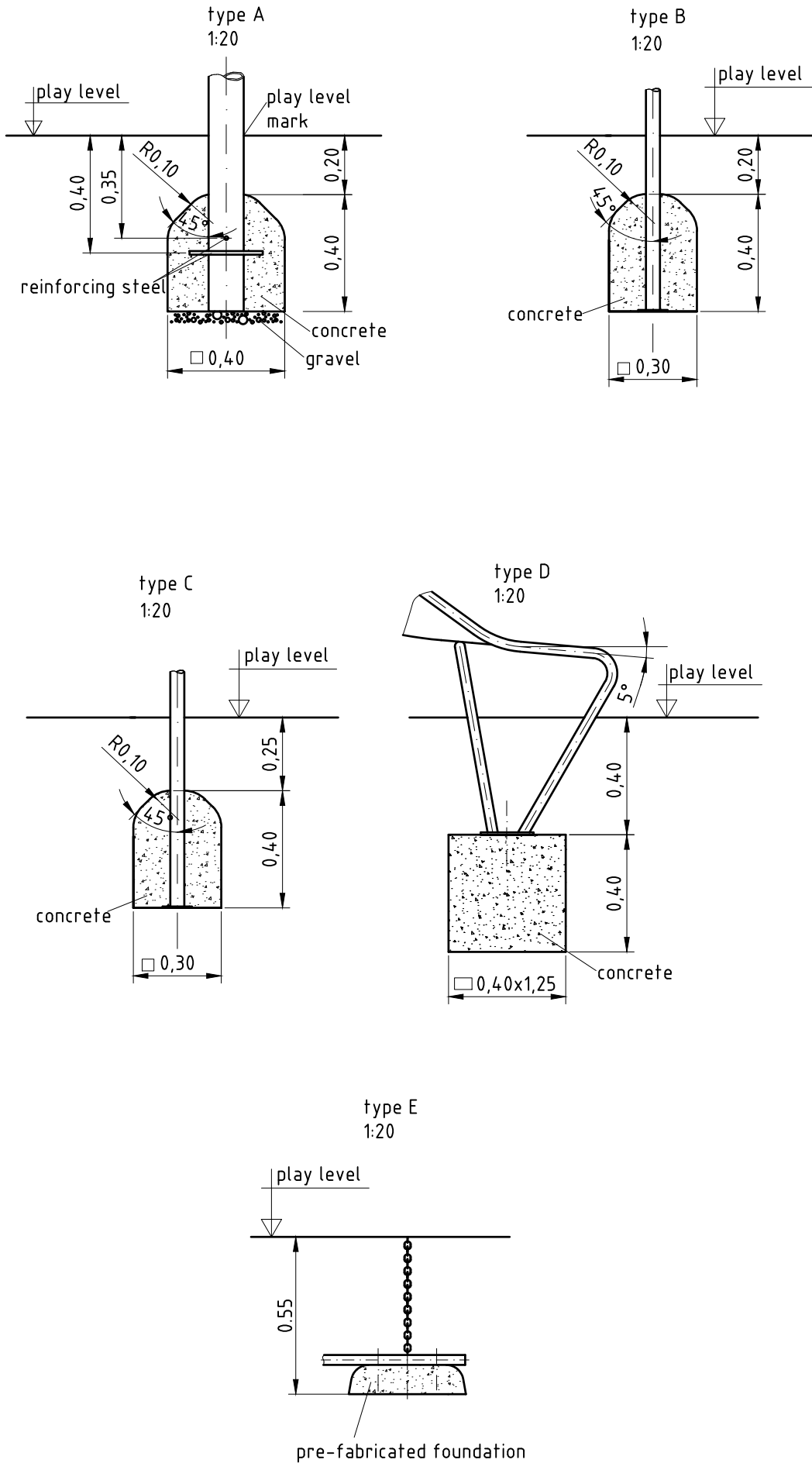

Item: **031590503**
 K&K Combi sand works
 Location:

Order:

1293368

Building Project:

12 x SFES1200001 Platform fastening to stainless steel post, nut on the side of the platform

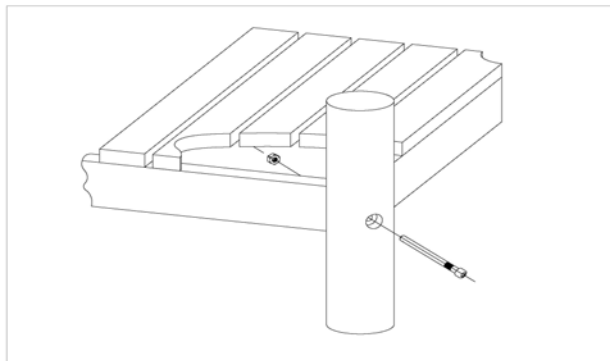

per SC	Total	K&K-Item	Marking
1 x	12 x	3430021	Lock nut M12 DIN985 A2
1 x	12 x	2030651	Cheese head screw with pin M12 x 125

6 x SFES1200002 2 platforms arranged across in equal height at stainless steel posts

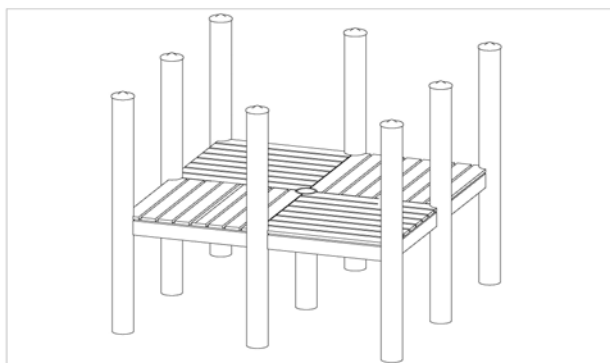

per SC	Total	K&K-Item	Marking
1 x	6 x	3430021	Lock nut M12 DIN985 A2
1 x	6 x	3430025	Washer Ø 13 DIN125 A2
1 x	6 x	2030249	Cheese head screw M12 x 150 with pin

28 x SFES1210001 Standard bolting of attachment parts (except platforms) to stainless steel posts

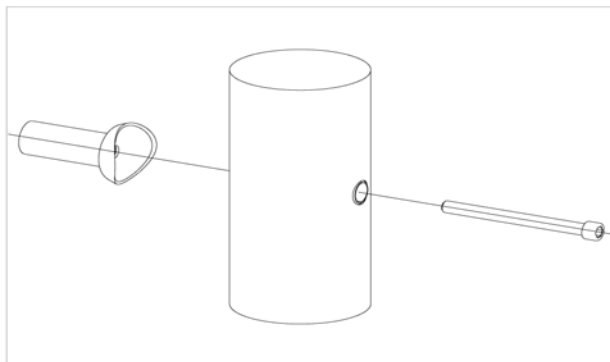

per SC	Total	K&K-Item	Marking
1 x	28 x	2030168	Cheese head screw with pin M12x140

1 x SFAS1230003 Chain ladder 1,60 m at platform joist

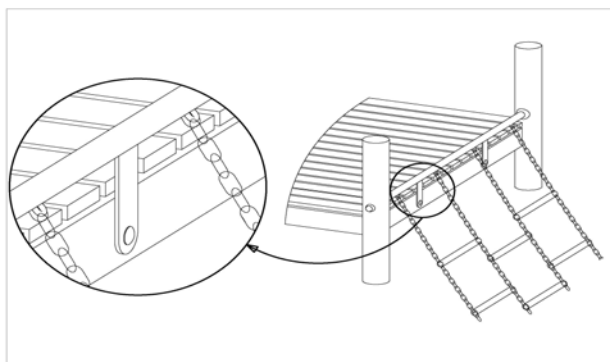

per SC	Total	K&K-Item	Marking
2 x	2 x	3300056	white protective screw cap - lower part, M10
2 x	2 x	3300057	white protective screw cap - upper part, M10
2 x	2 x	3430048	Lock nut M10 DIN 985 A2
2 x	2 x	3430014	Washer Ø 10,5 DIN 125 B A2
2 x	2 x	3400416	Mushroom head screw M10 x 65 DIN603 A2

Item: **031590503**
 K&K Combi sand works
 Location:

Order:

1293368

Building Project:

1 x SFAS1230004 Climbing post fastening to platform joist

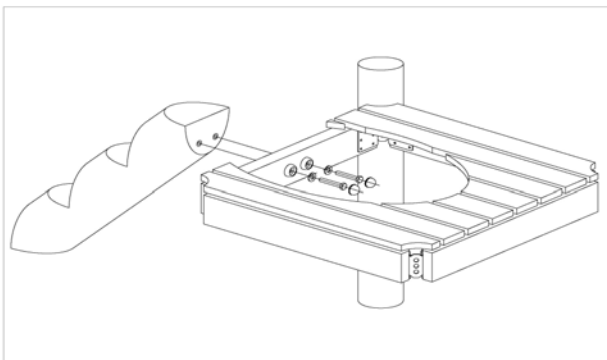

per SC	Total	K&K-Item	Marking
2 x	2 x	3430025	Washer Ø 13 DIN125 A2
2 x	2 x	3300055	red protective screw cap - upper part, domed M12
2 x	2 x	3400414	hexagon head cap screw M12 x 75 DIN931 A2
2 x	2 x	3300045	Screw cover cap, flat, M 12 PA6 P1 (lower part) colour: red/RAL 2002

1 x SFES1260002 Fastening of chain of sand pulley to steel post

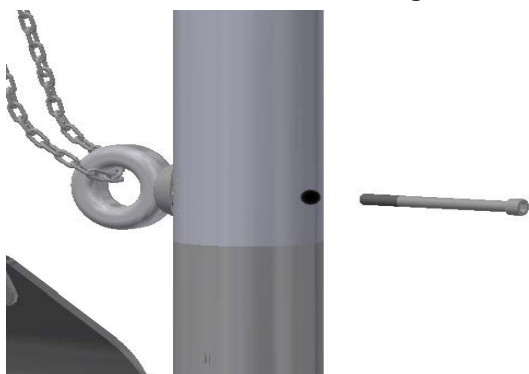

per SC	Total	K&K-Item	Marking
1 x	1 x	2030168	Cheese head screw with pin M12x140
1 x	1 x	1040731	weld piece/post attachment/twist protection

3 x SFES1240001 Roof frame of spire roof 80° at stainless steel posts

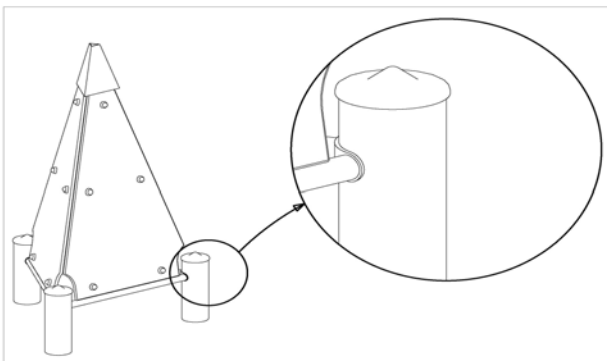

per SC	Total	K&K-Item	Marking
1 x	3 x	3430025	Washer Ø 13 DIN125 A2
1 x	3 x	3430051	Hexagon cap nut M12 DIN 986 A2
1 x	3 x	2030169	Cheese head screw with pin M12 x 130

1 x SFAS1240020 Bolt down control lug to wind turbine

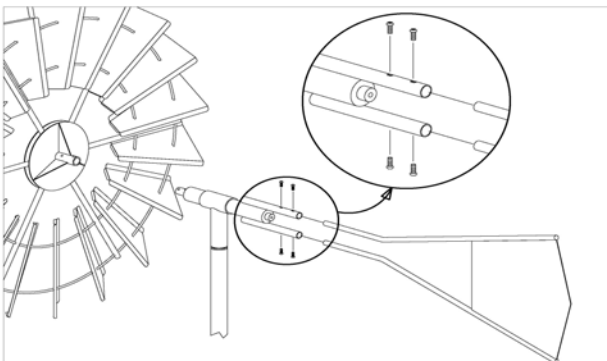

per SC	Total	K&K-Item	Marking
4 x	4 x	3400324	cheese head screw M6 x 10 DIN912 A2

Item: **031590503**
 K&K Combi sand works
 Location:

Order:

1293368

Building Project:

1 x SFAS1240018 Dowel and bolt down rotor of windturbine to bearing spindle

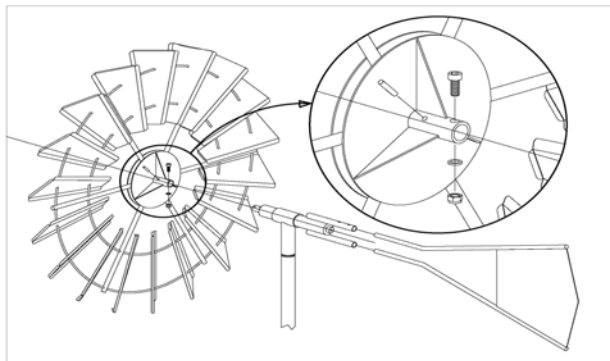

per SC	Total	K&K-Item	Marking
1 x	1 x	3430035	Lock nut M8 DIN985 A2
1 x	1 x	3430009	washer Ø 8,4 DIN125 A2
1 x	1 x	3440040	dowel pin Ø 8 x 40 DIN1481 A2
1 x	1 x	3400391	cylinder head screw M8 x 50 DIN912 A2

1 x SFAS1240019 Bolt down rotor protection to rotor/bearing spindle

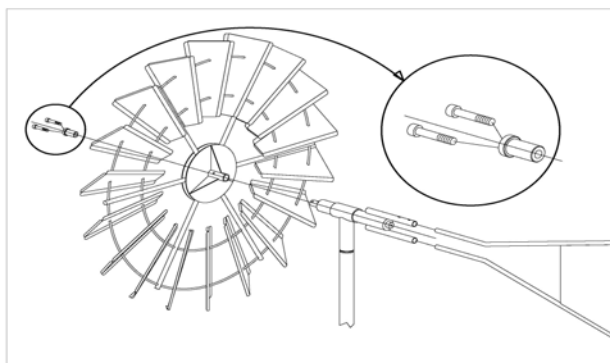

per SC	Total	K&K-Item	Marking
2 x	2 x	3400603	cheese head screw M8 x 70 DIN912 A2
1 x	1 x	2030110	rotor protection

1 x SFAS1070006 Slide run-out section (up to 2,00 m) on foundation stone bolt assembly

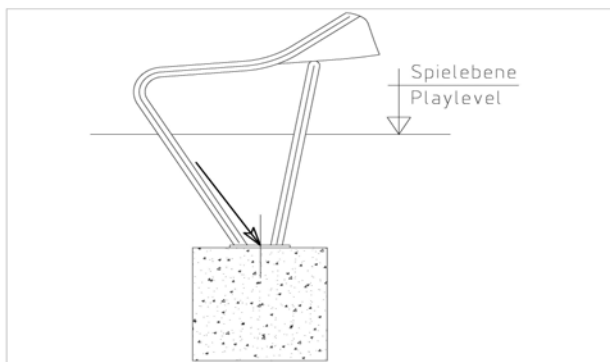

per SC	Total	K&K-Item	Marking
2 x	2 x	1070365	Set of stone bolts for slide run-out section M12x160

3 x SFAS1230007 Connection pipe between chain ladder/space net/ climbing net and prefabricated foundation (item N° 15150)

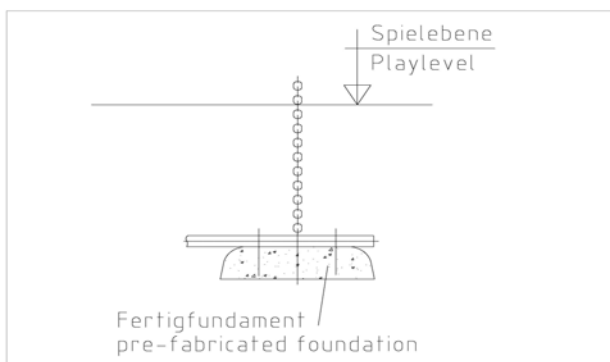

per SC	Total	K&K-Item	Marking
2 x	6 x	3430025	Washer Ø 13 DIN125 A2
2 x	6 x	3400498	Hexagon head cap screw M12 x 55 DIN931 A2

Item: **031590503**
 K&K Combi sand works
 Location:

Order:

1293368

Building Project:

1 x SFWZ000001 Security TORX wrench TR40

per SC	Total	K&K-Item	Marking
1 x	1 x	3490081	Security TORX wrench TR40



1 x SFWZ000009 Hexagon insert socket driver 10mm 1/2" with borehole for Pin

per SC	Total	K&K-Item	Marking
1 x	1 x	2030170	Hexagon insert socket driver 10 mm 1/2" with drill hole for Pin



1 x SFWZ000012 Lubricating metal (30g box) incl. brush

per SC	Total	K&K-Item	Marking
1 x	1 x	5300039	Lubricating metal box 30g
1 x	1 x	5200026	Brush for lubricating metal

