

1. Assign a device location considering the space requirements (impact area). Excavate soil for foundations, according to drawing. Please note: To achieve maximum stability and safe installation, a moderate level of soil solubility is required.
  2. Pour in a drain layer of gravel of approx. 10 cm thickness between the bottom of the tubular pedestals and plain base of foundation.
  3. Insert reinforcing steel into the corresponding holes of the tubular pedestals.
  4. Place posts type A (see foundation layout) according to the corresponding number into the respective foundation hole. Play level mark (=aluminium blind rivet) complies with the installation depth. Align every post by means of the play level mark facing into the same direction (see detail or foundation layout).
  - 5. For installation of the pre-assembled components and/or single parts, the screws slightly have to be lubricated with installation paste!**  
Screw together platforms and posts by using the respective hole in the mounting bracket (according to chart).
- Tighten all screws after having aligned all components.**  
Screw connections see details in enclosed list.
- We recommend not to insert the protection caps enclosed before first maintenance as they are only suitable for one-time use (see description in item No. 9).
6. Grout foundations with compressed concrete C20/25, chamfer and round off the edges, cover the foundations with a surface which meets the requirements for impact attenuation so that the critical fall height of the surfacing shall be equal to, or greater than, the free height of fall of the equipment (acc. to EN 1176-1).
  7. Release for play after concrete foundations have set.
  8. Check all screw connections acc. to maintenance instructions after 4-5 weeks and retighten, if necessary. Afterwards cover the screw heads with protection caps as follows: Insert grey protection caps into the countersunk drills (e.g. for posts). The non-countersunk drills (e.g. for railings or a slide) have to be covered with the red protection caps by placing them onto the base part. Strongly pound them (e.g. by using a plastic mallet) until they audibly snap into the base part groove.

Please ensure that all special tools supplied (e.g. Allen key for secured Allen screws etc.) and all specific documents which are or may be useful for safety management acc. to EN 1176-7 (e.g. invoice, delivery note, order acknowledgement, installation instructions, maintenance instructions) are forwarded to the persons responsible.

**Necessarily insert all attachment parts before tightening the screws. It is NOT possible to insert them afterwards.**

platform orientation/numbers  
1:100

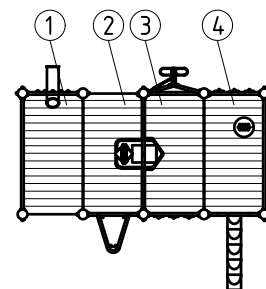
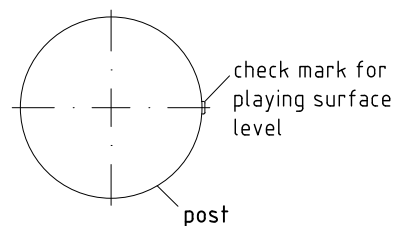

chart for platform fastenings

No.	height	drill hole position in mounting bracket		
		top	middle	bottom
①	0,40		x	
②	0,40	x		
③	1,00		x	
④	1,00	x		

detail of check mark  
1:5



platform fastening  
1:10

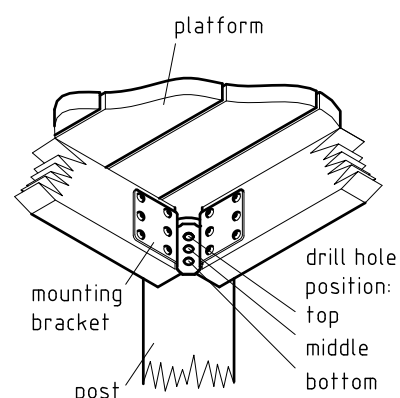

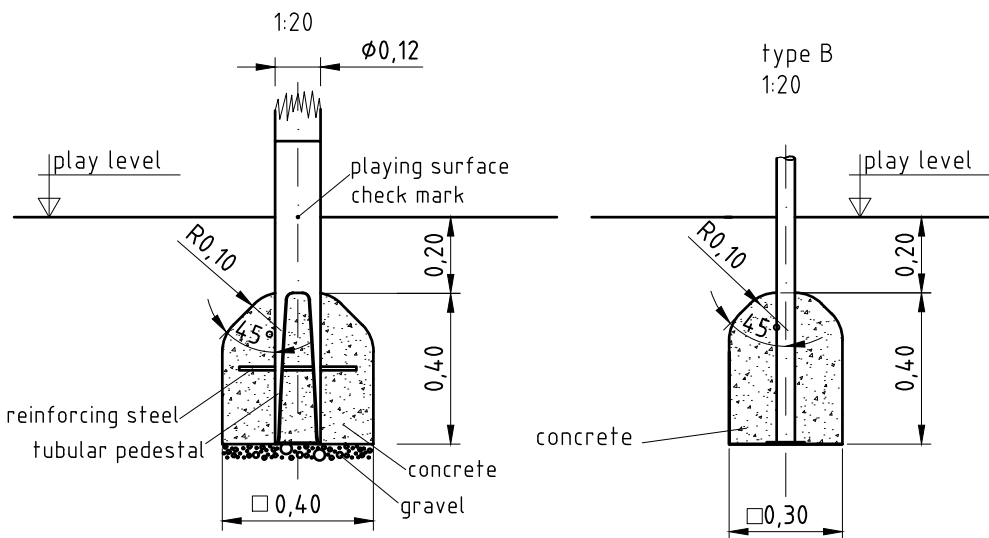
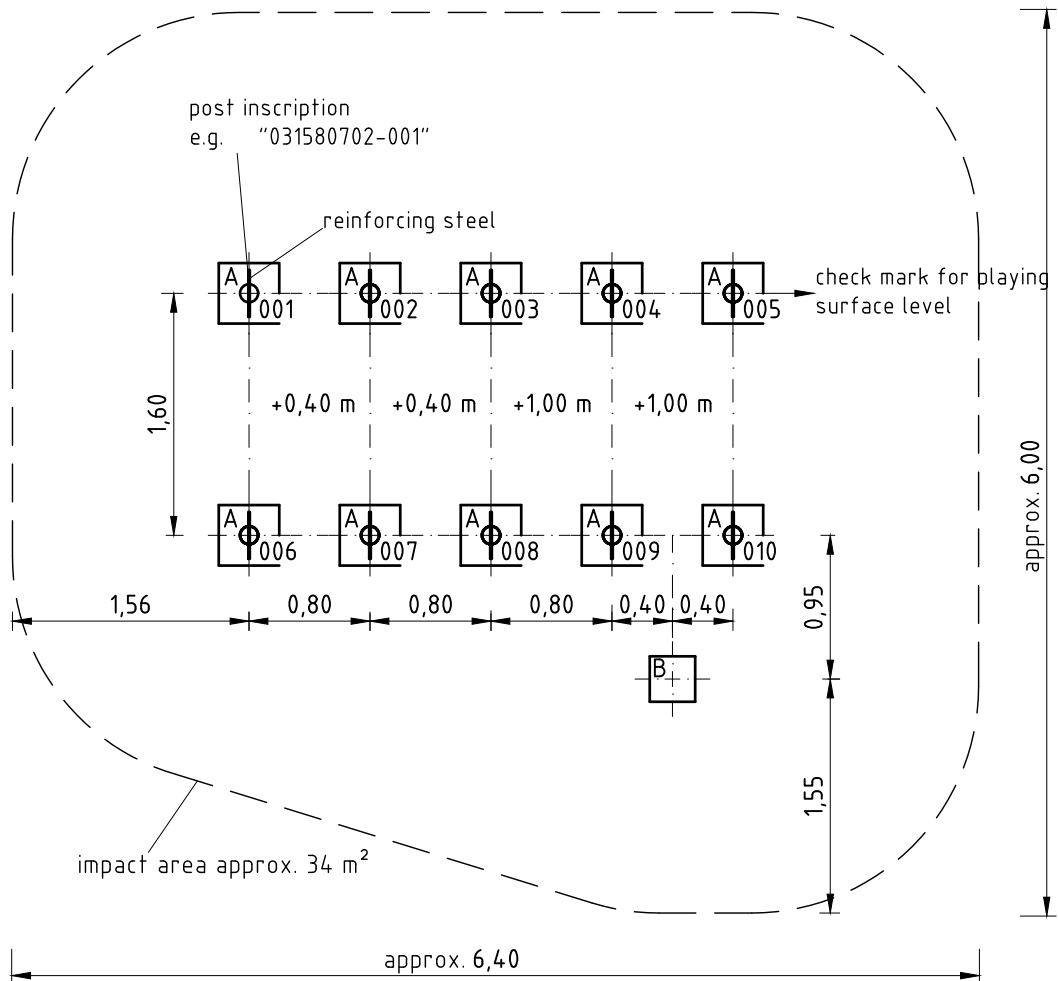
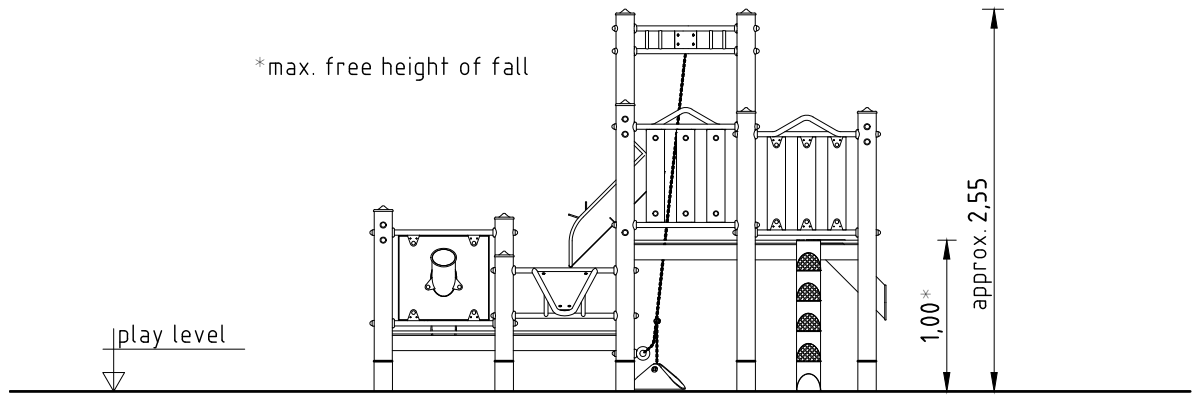

# Installation

Item No.  
0-31580-702

Description  
K&K Cargo station

Scale  
1:50

Date  
07/18 DW

Page  
2/2

Item: **031580702**  
 K&K Cargo station  
 Location:

Order:

1293365

Building Project:

**16 x SFRS1200001 Platform at Robinia post, nut is platform-sided**

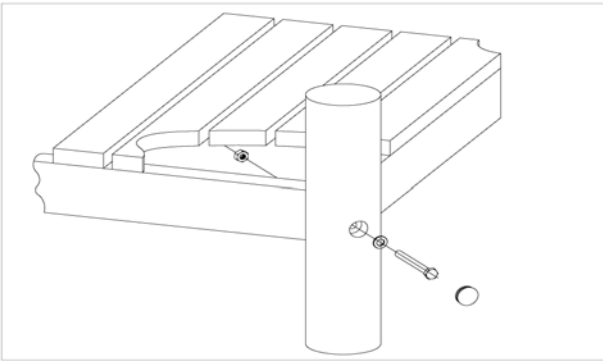

per SC	Total	K&K-Item	Marking
1 x	16 x	3400700	Hexagon head screw M12 x 120 DIN931 A2 with screw security coating/FGB red
1 x	16 x	3300016	Grey domed plastic cover cap SL 36 G
1 x	16 x	3430129	Washer Ø 14 DIN1440 A2
1 x	16 x	3430021	Lock nut M12 DIN985 A2

**38 x SFRS1210001 Standard bolting of barriers, handrails, slides to Robinia posts**

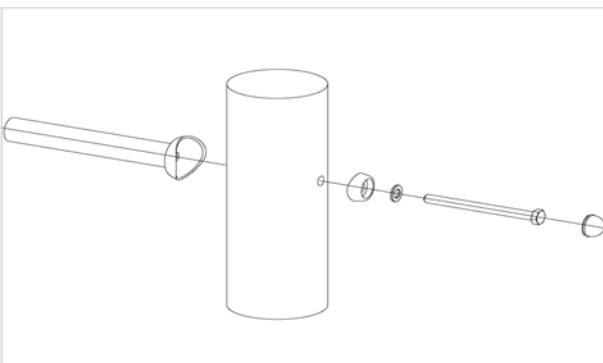

per SC	Total	K&K-Item	Marking
1 x	38 x	3300054	red protective screw cap - lower part, domed M12
1 x	38 x	3300055	red protective screw cap - upper part, domed M12
1 x	38 x	3430025	Washer Ø 13 DIN125 A2
1 x	38 x	3400702	Hexagon head cap screw M12 x 160 DIN931 A2 with screw security coating FGB red

**1 x SFAS1230004 Climbing post fastening to platform joist**

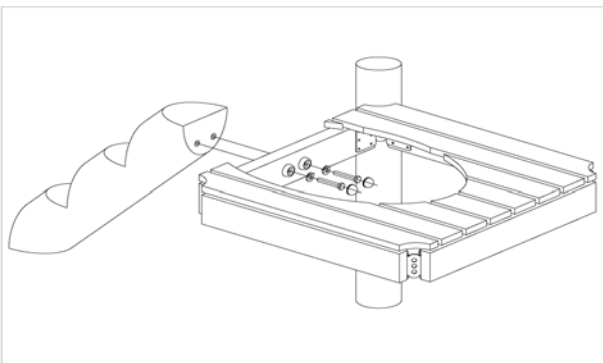

per SC	Total	K&K-Item	Marking
2 x	2 x	3430025	Washer Ø 13 DIN125 A2
2 x	2 x	3400414	hexagon head cap screw M12 x 75 DIN931 A2
2 x	2 x	3300055	red protective screw cap - upper part, domed M12
2 x	2 x	3300045	Screw cover cap, flat, M 12 PA6 P1 (lower part) colour: red/RAL 2002

**1 x SFRS1260003 Fastening of chain of sand pulley to post**

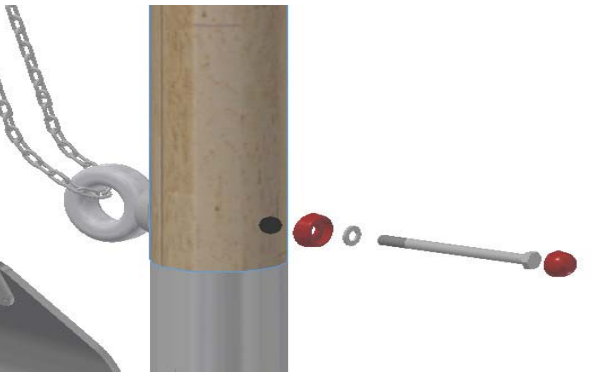

per SC	Total	K&K-Item	Marking
1 x	1 x	3430025	Washer Ø 13 DIN125 A2
1 x	1 x	3300055	red protective screw cap - upper part, domed M12
1 x	1 x	3400702	Hexagon head cap screw M12 x 160 DIN931 A2 with screw security coating FGB red
1 x	1 x	3300054	red protective screw cap - lower part, domed M12
1 x	1 x	1040731	weld piece/post attachment/twist protection

Item: **031580702**  
K&K Cargo station

Order:

1293365

Location:

Building Project:

**1 x SFWZ000001 Security TORX wrench TR40**

per SC	Total	K&K-Item	Marking
1 x	1 x	3490081	Security TORX wrench TR40



**10 x SFES1270007 Reinforcing steel for tubular pedestals**

per SC	Total	K&K-Item	Marking
1 x	10 x	2130000	Reinforcing steel Ø 10 x 310 DIN 488



**1 x SFWZ000012 Lubricating metal (30g box) incl. brush**

per SC	Total	K&K-Item	Marking
1 x	1 x	5300039	Lubricating metal box 30g
1 x	1 x	5200026	Brush for lubricating metal

