



INSTALLATION

Actio 230 0-27230-001



Werkzeuge tools

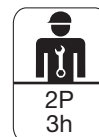
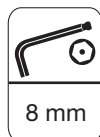
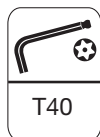

Kaiser & Kühne

customer

DE

1. Gerätestandort unter Berücksichtigung des Platzbedarfs (Aufprallfläche) festlegen.
2. Bodenaushub für Fundamente nach Zeichnung vornehmen. Bitte beachten Sie: Für eine standsichere Montage werden mittelschwer lösbare Bodenarten vorausgesetzt.
3. Ca. 10 cm dicke Grobkiesschicht als Drainschicht zwischen Unterseite der Standpfosten und der Fundamentsohle einbringen.
4. Rohrbogenstütze in das jeweilige Fundamentloch stellen.
5. Bauteile lose verschrauben.
6. **Zum Einbauen der vormontierten Bauteile bzw. Einzelteile müssen die Schrauben mit der gelieferten Montagepaste leicht gefettet werden.** Erst nach dem Ausrichten alle Schrauben fest anziehen.
7. Fundamente mit Stampfbeton C20/25 füllen, und mit einem Bodenmaterial abdecken, dessen kritische Fallhöhe größer gleich der maximalen freien Fallhöhe ist (s. EN 1176-1).
8. Freigabe zum Bespielen erst nach Abbinden der Betonfundamente.
9. Alle Schraubverbindungen gemäß Wartungsanleitung nach 4-5 Wochen überprüfen und ggf. fest nachziehen.

Alle mit dem Gerät gelieferten Spezialwerkzeuge (z.B. Innensechskant-Schlüssel für gesicherte Schrauben etc.) sowie alle gerätespezifischen Unterlagen, die für das Sicherheitsmanagement nach EN 1176-7 wichtig sind oder sein könnten wie z.B. Rechnung, Lieferschein oder Auftragsbestätigung, Montageanleitung und Wartungsanleitung im Original oder in einer Kopie an die zuständigen Stellen weiterleiten.

Bitte beachten Sie:

Um einen sicheren und unfallfreien Spielbetrieb mit diesem Gerät zu gewährleisten, müssen die im Wartungsplan aufgeführten Tätigkeiten unbedingt ausgeführt werden.

Vor dem Anziehen der Schraubverbindungen unbedingt alle Anbauteile einsetzen. Ein nachträgliches Einsetzen ist NICHT möglich!

GB

1. Assign a device location considering the space requirements (impact area).
2. Excavate soil for foundations, according to drawing.

Please note: To achieve maximum stability and a safe installation, a moderate level of soil solubility is required.
3. Pour in a drain layer of gravel of approx. 10 cm thickness between the bottom of the posts and plain base of foundation.
4. Place posts into the respective foundation hole.
5. Gently tighten component parts.
6. **For installation of the pre-assembled components and/or single parts, the screws slightly have to be lubricated with installation paste!** Tighten all screws after having aligned all components.
7. Grout foundations with compressed concrete C20/25, cover the foundations with a surface which meets the requirements for impact attenuation so that the critical fall height of the surfacing is equal to, or greater than, the free height of fall of the equipment (acc. to EN 1176-1).
8. Release for play after concrete foundations have set.
9. According to maintenance instructions, check all screw connections after 4-5 weeks and retighten, if necessary.

Please ensure that all special tools supplied (e.g. Allen key for secured Allen screws etc.) and all specific documents which are or may be useful for safety management acc. to EN 1176-7 (e.g. invoice, delivery note, order acknowledgement, installation instructions, maintenance instructions) are forwarded to the persons responsible.

Please note:

For safe playing circumstances without accidents, it is essential to execute the scale of operations listed in the maintenance schedule.

Necessarily insert all attachment parts before tightening the screws. It is NOT possible to insert them afterwards.

Geräteraum
space occupied by equipment

4,40 x 2,29 x 2,93 m

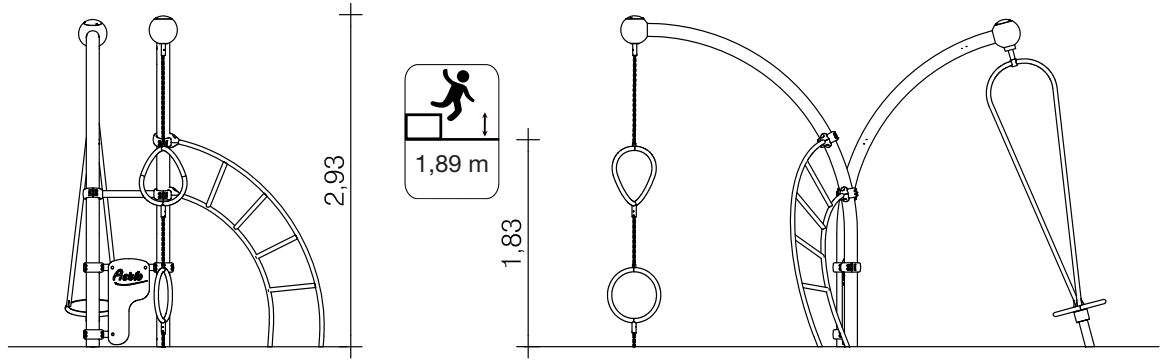

Mindestraum
minimum space

7,96 x 5,33 x 2,93 m

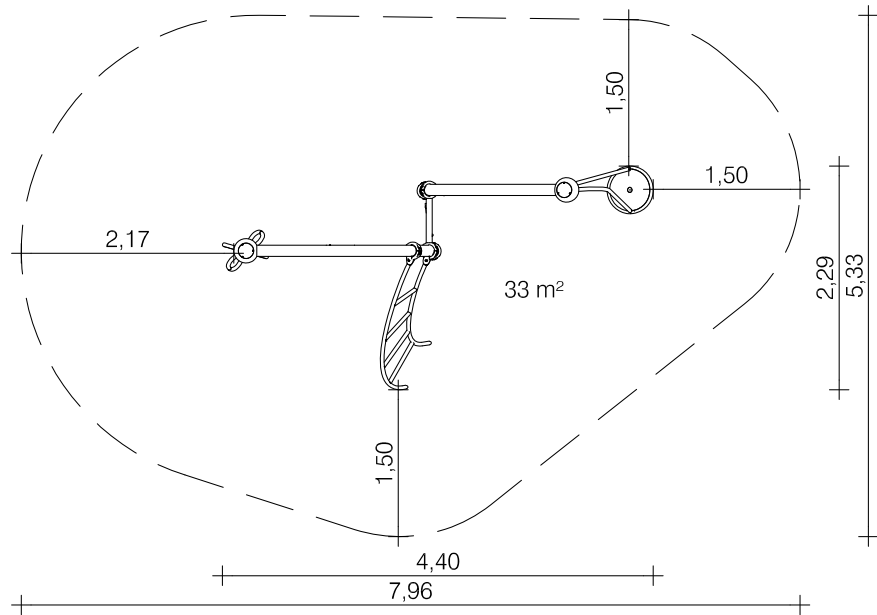

Fundamentplan
foundation plan

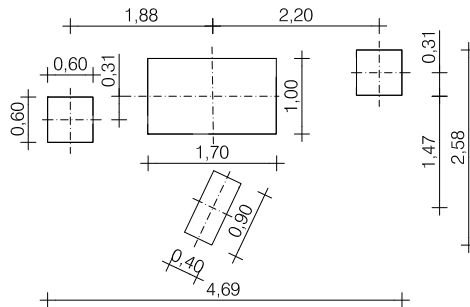
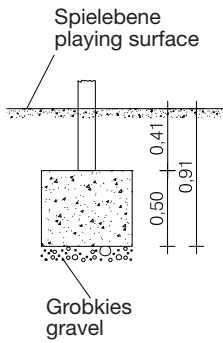
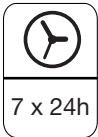
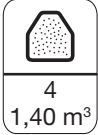

Komponenten
components

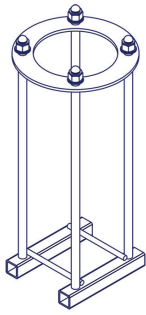
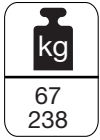

①
1090393
1x

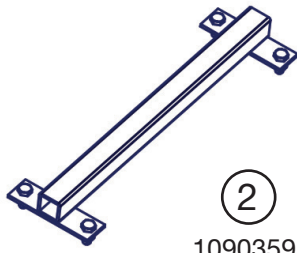

②
1090359
2x

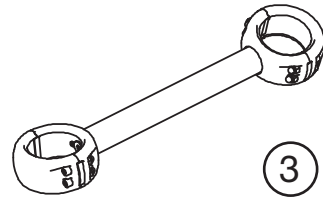

③
1090368
1x



④
2030434
1x

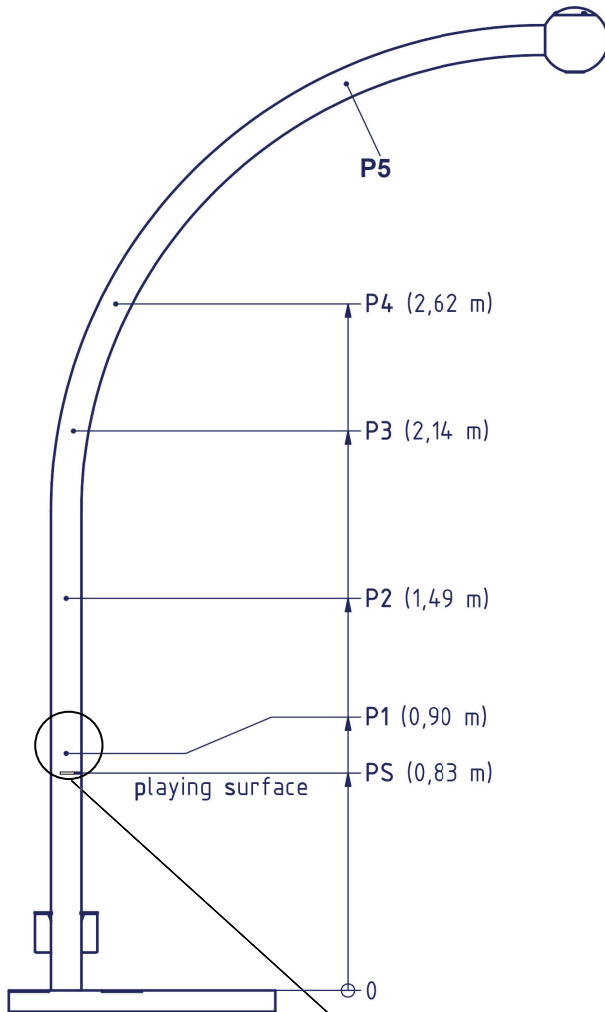

⑤
1090407
1x
67 kg

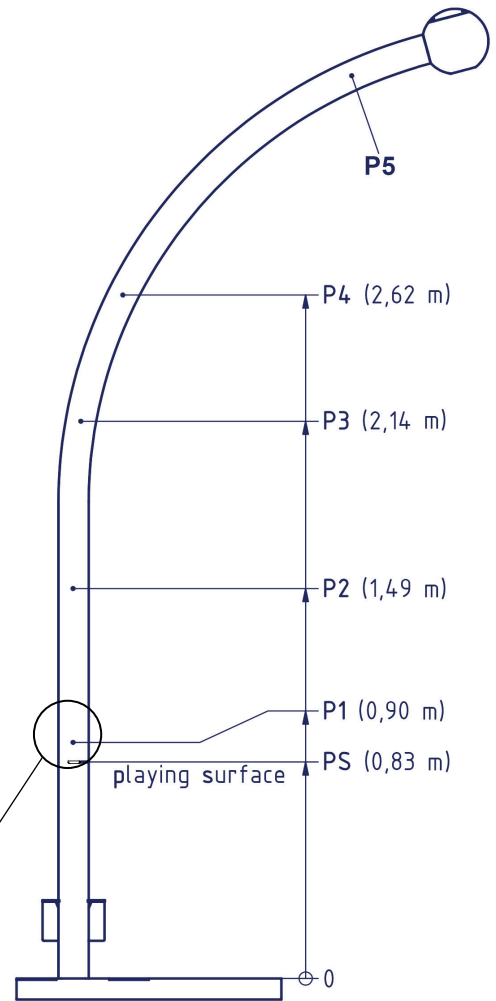
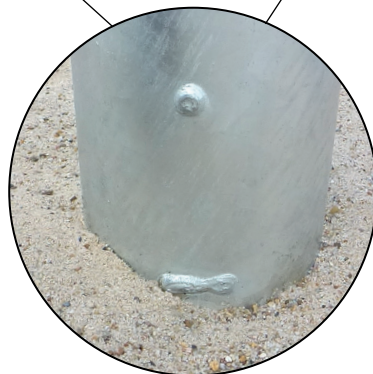

⑥
1090391
1x

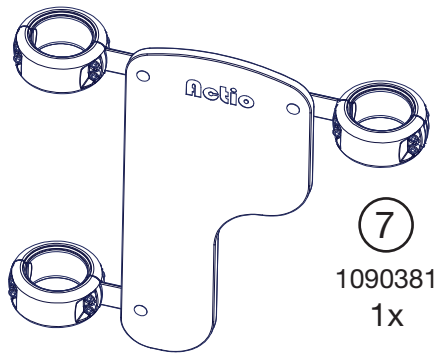

7
1090381
1x



8 1292859
1x

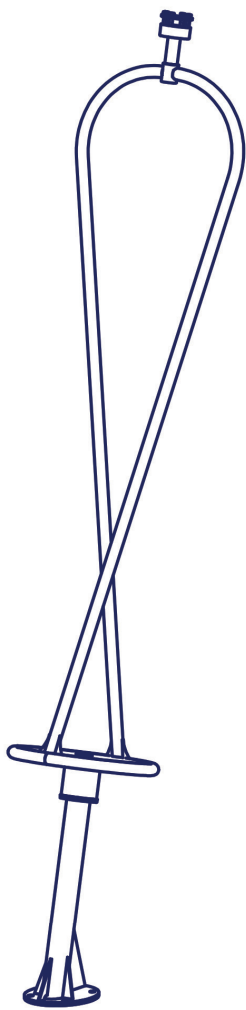

9 1090343
1x

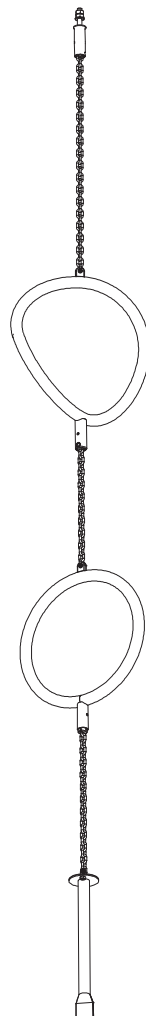

10 1090351
1x

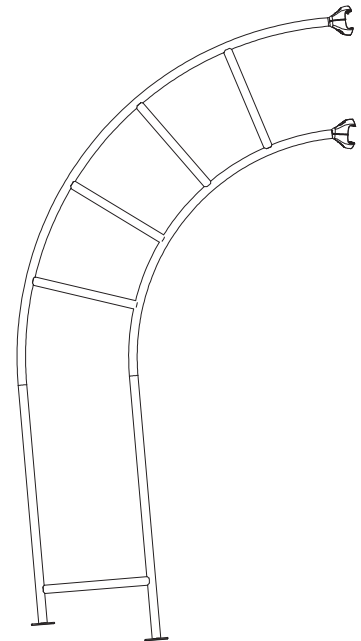

11 1090377
1x

Step 1



24 mm



min.
2,5 m

1090407
1x

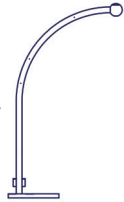

+

1090378
1x

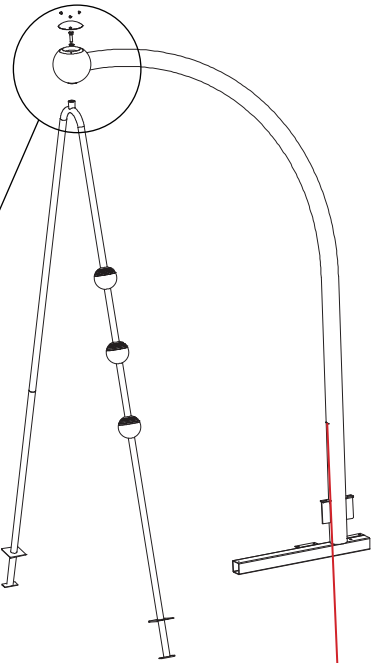
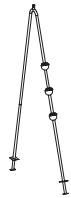

2



1x

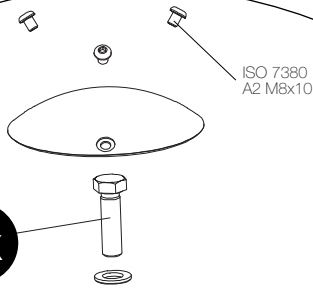

ISO 7380
A2 M6x10

1

1090378

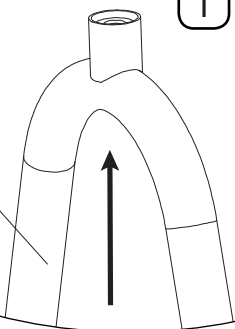

playing surface
ATTENTION



Step 2



19 mm

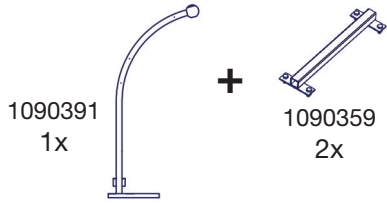

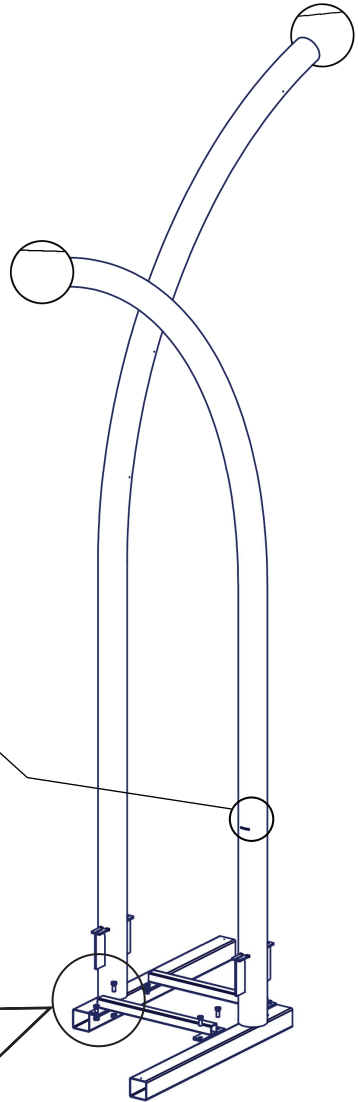

playing surface
ATTENTION

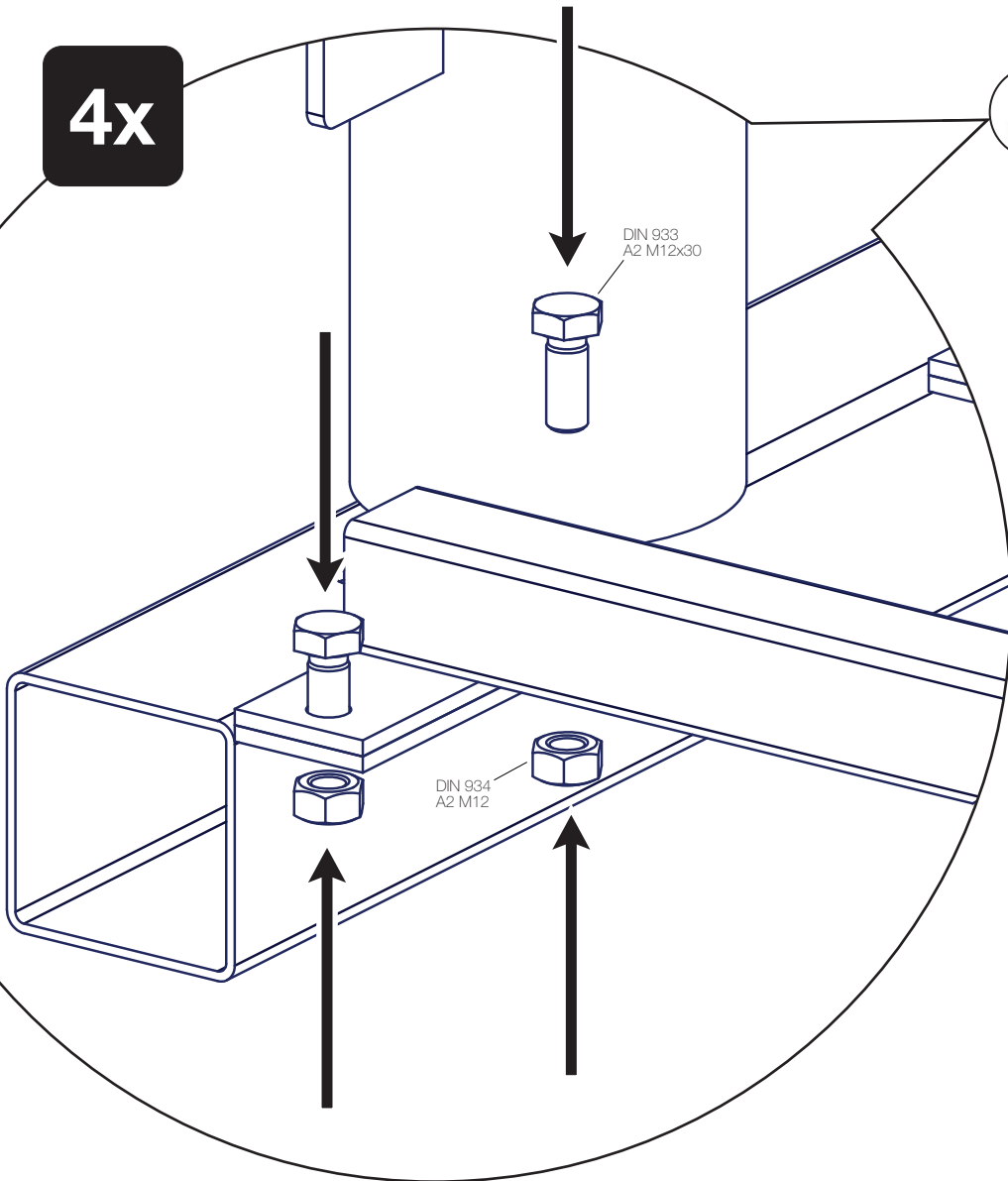

4x

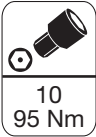

Step 3



+
1090368
1x



8x

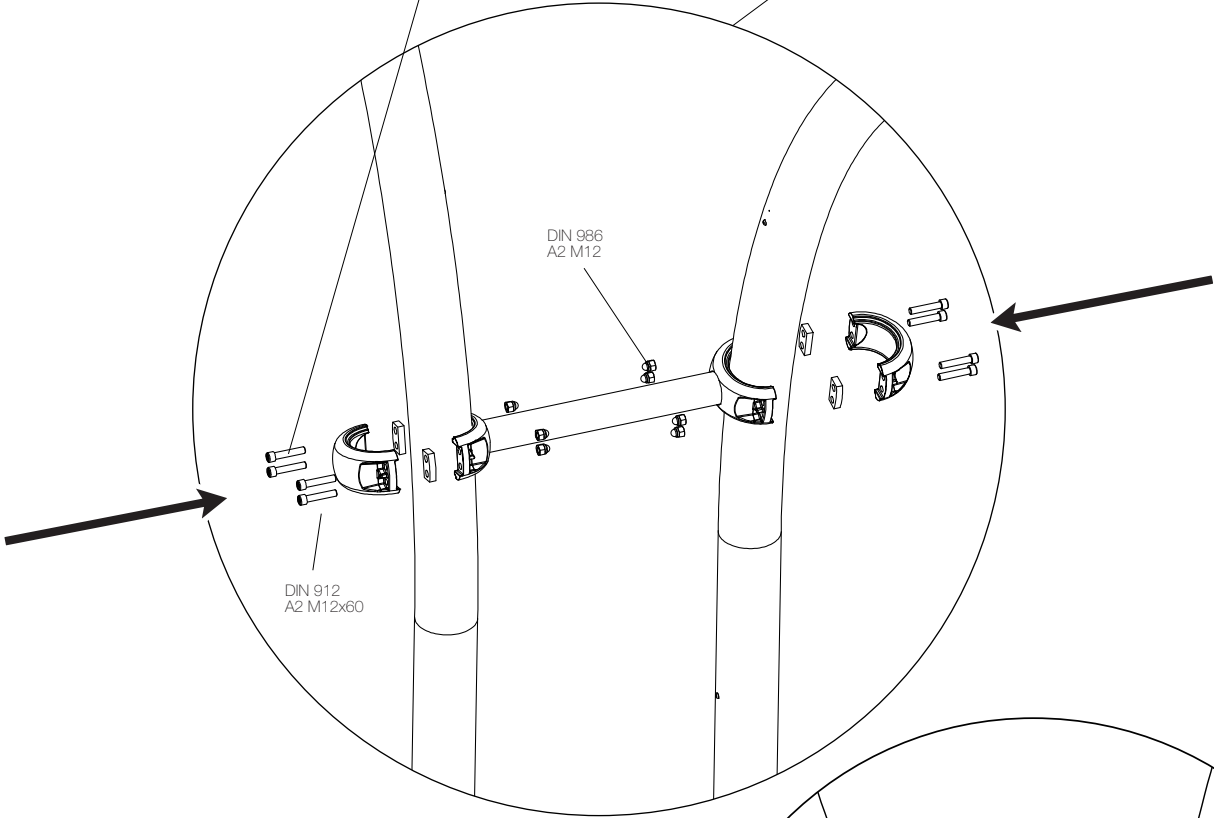
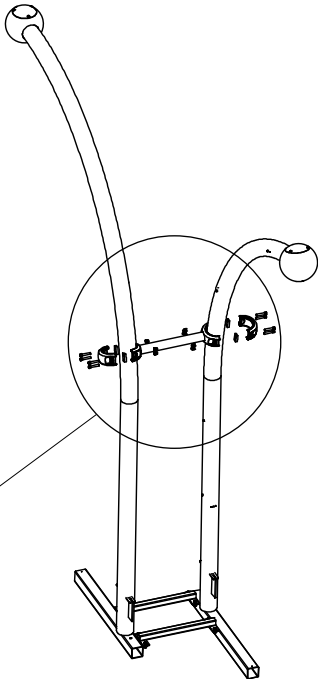

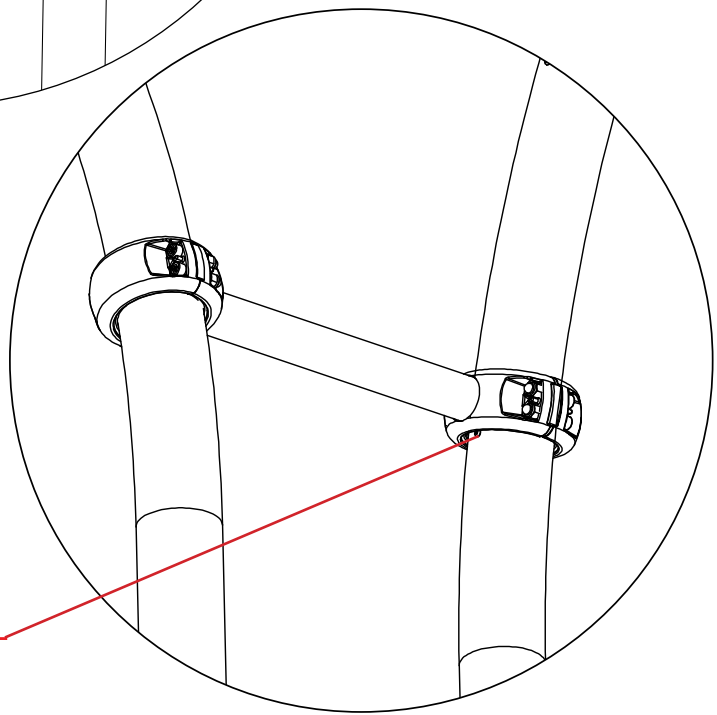

point level - P3
ATTENTION

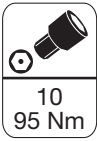

Step 4

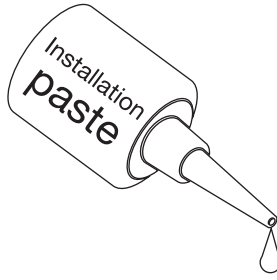

1090434
1x



4x

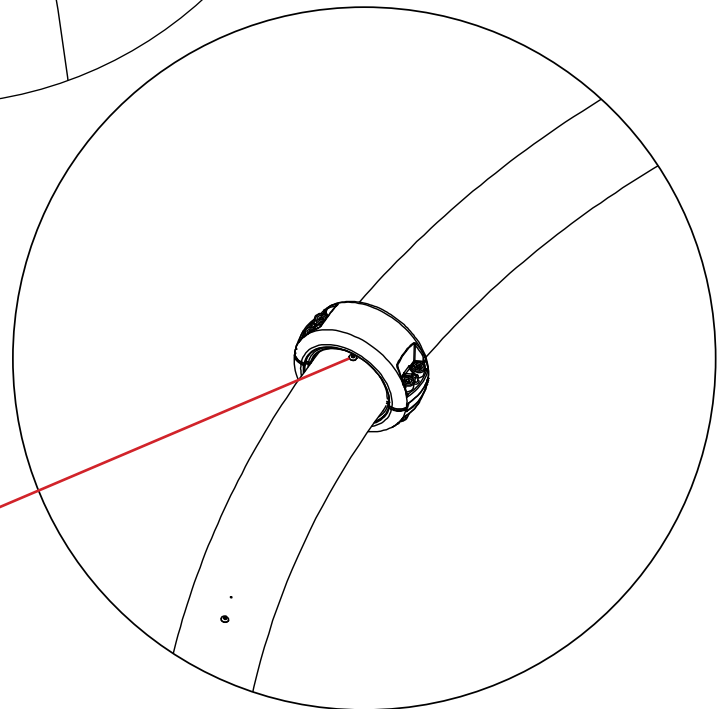
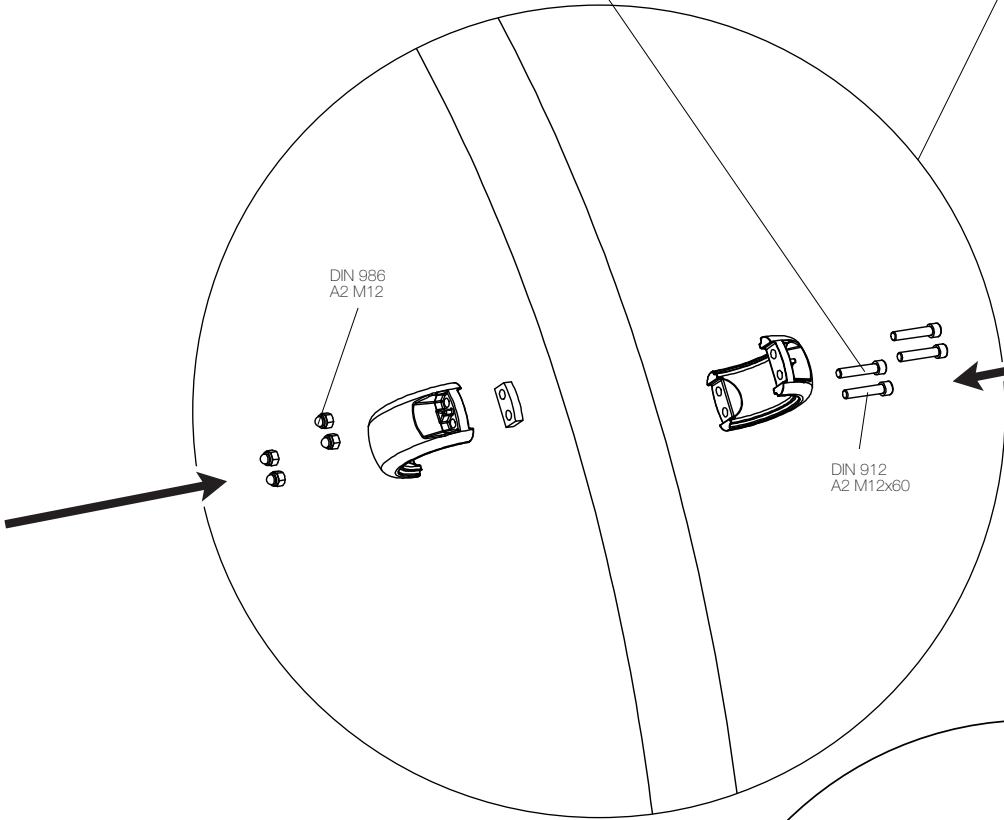
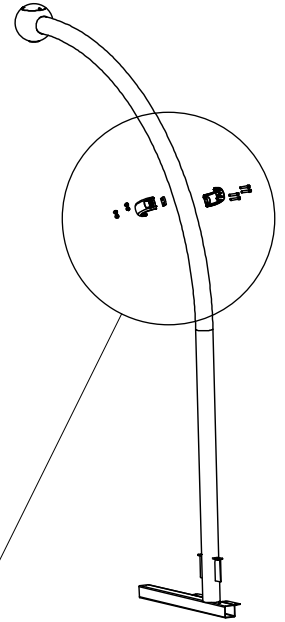

point level - P4
ATTENTION

Step 5

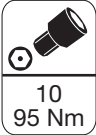

+
1090377
1x



2x

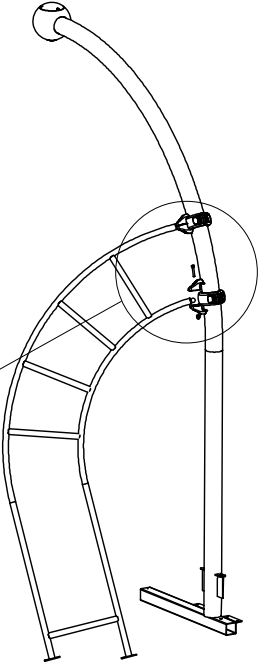
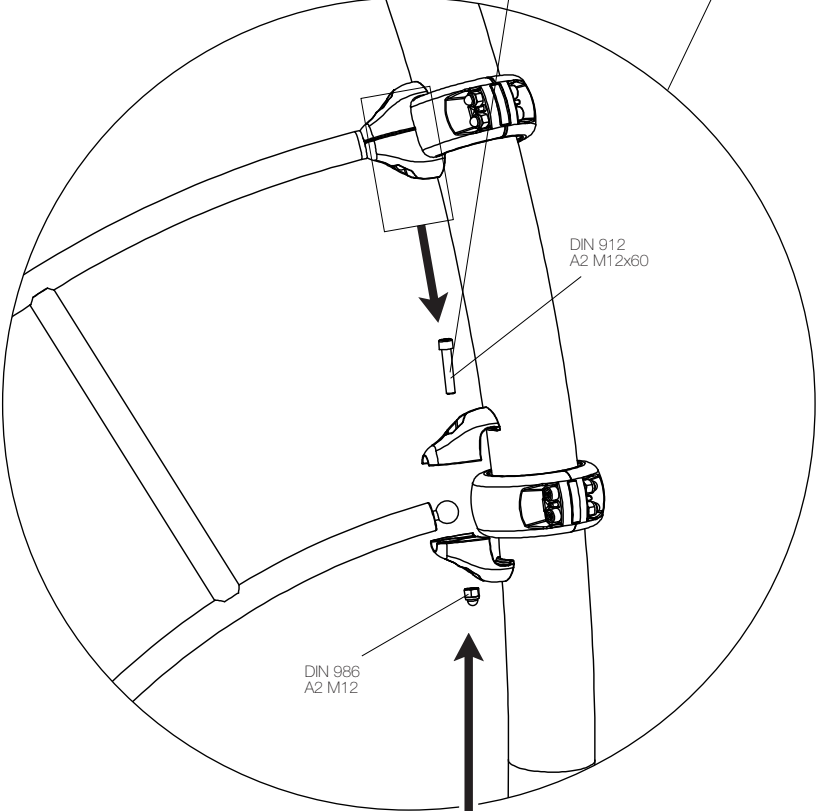

!
point level - P4
ATTENTION

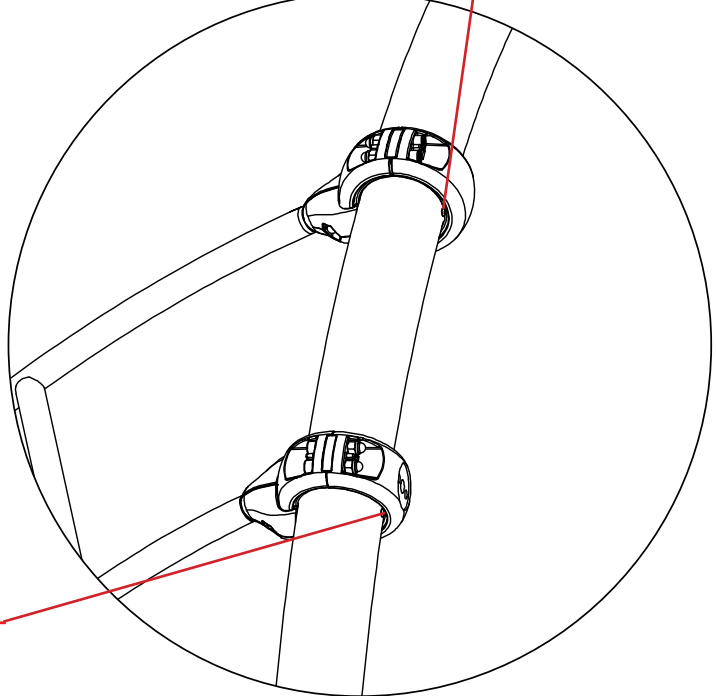

!
point level - P3
ATTENTION

Step 6

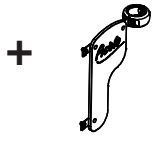

1090382
1x

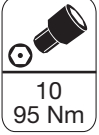

12x

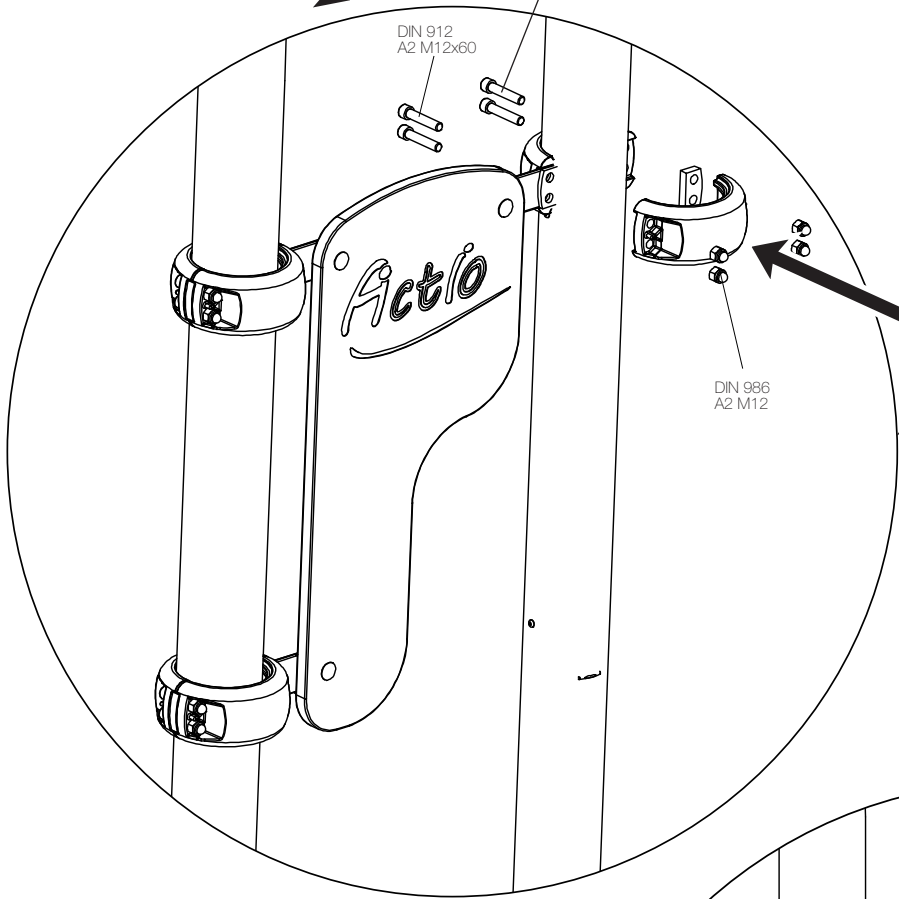
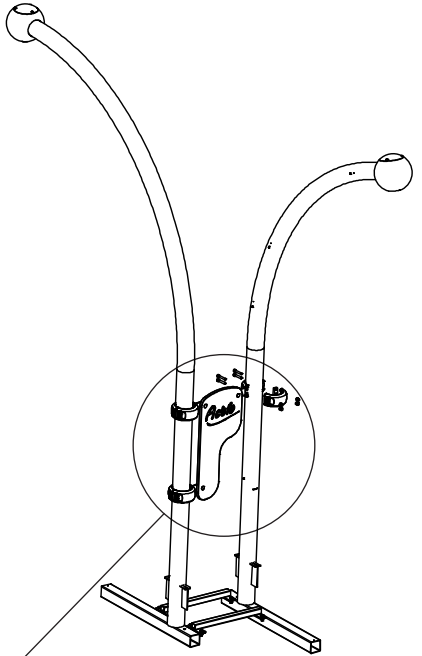

DIN 912
A2 M12x60

DIN 986
A2 M12

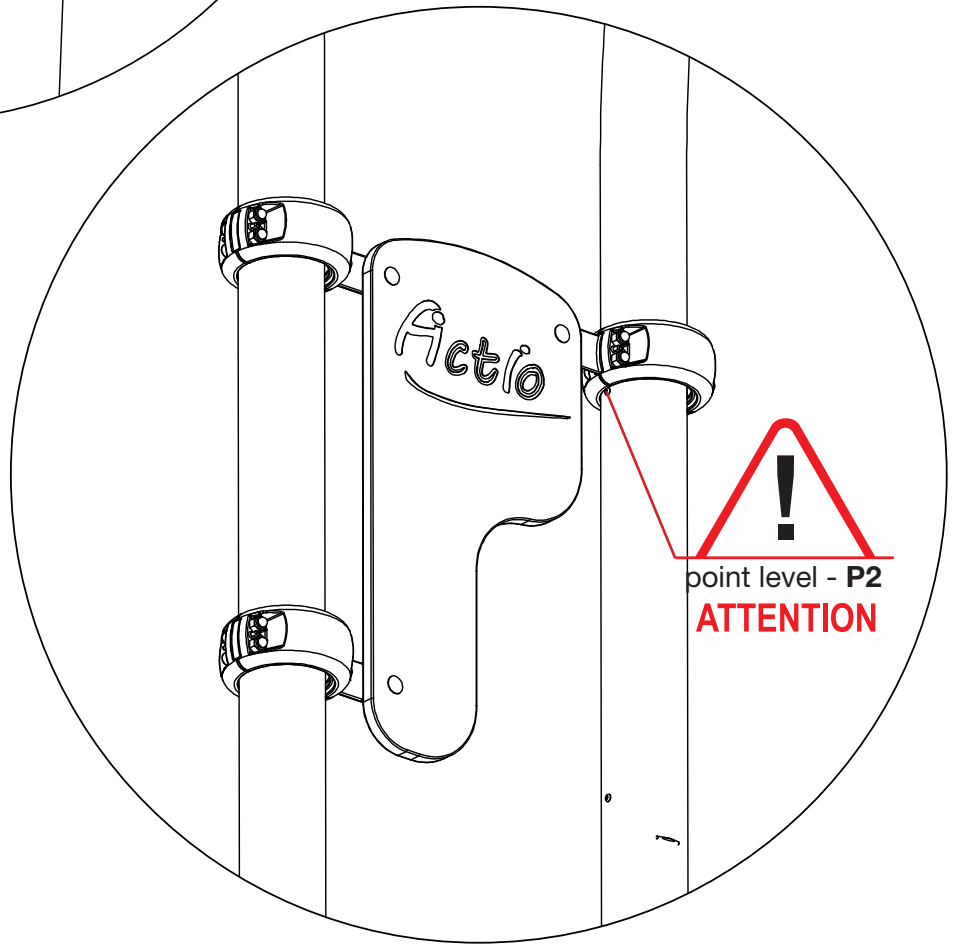

!
point level - P2
ATTENTION

Step 7



24 mm

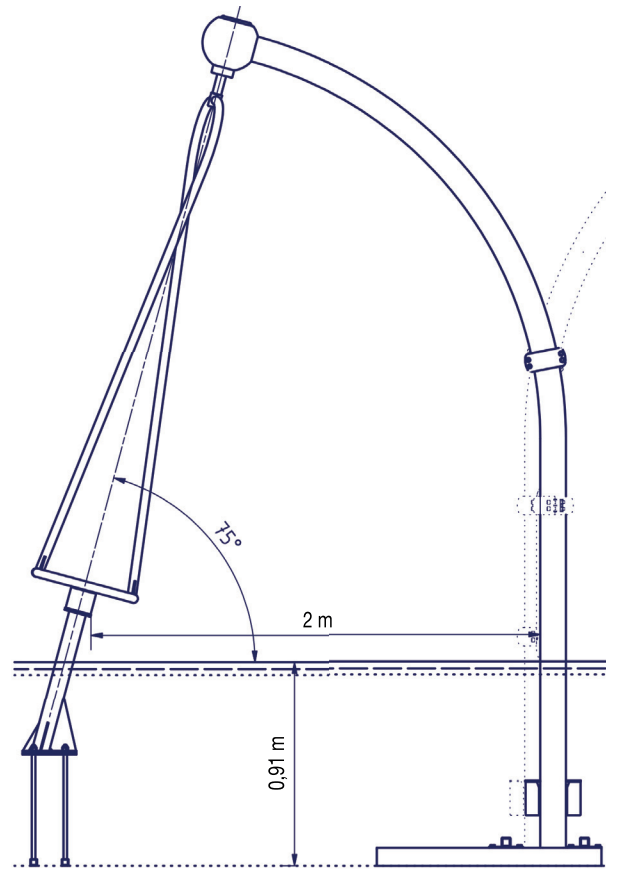
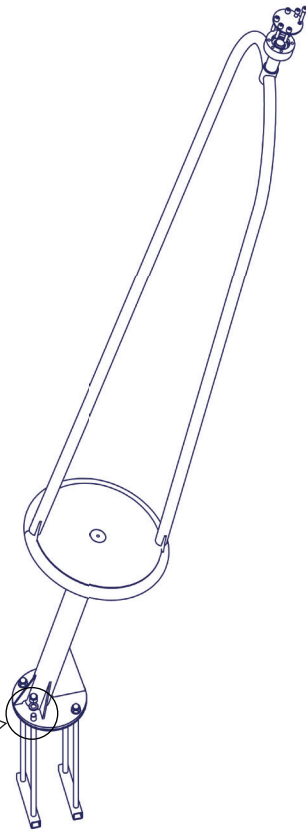
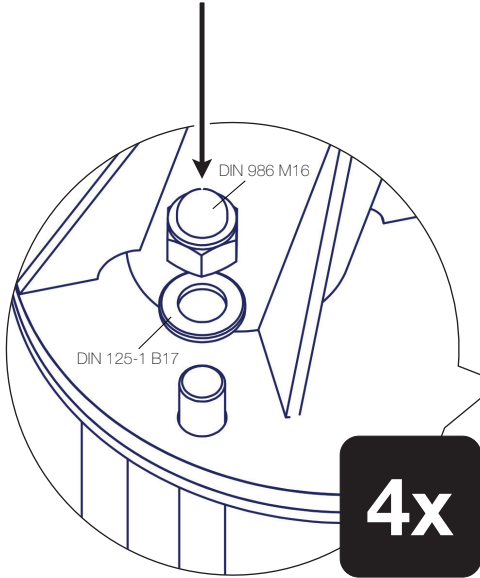
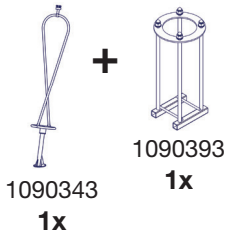

Step 8



T40



8 mm



min.
2,5 m

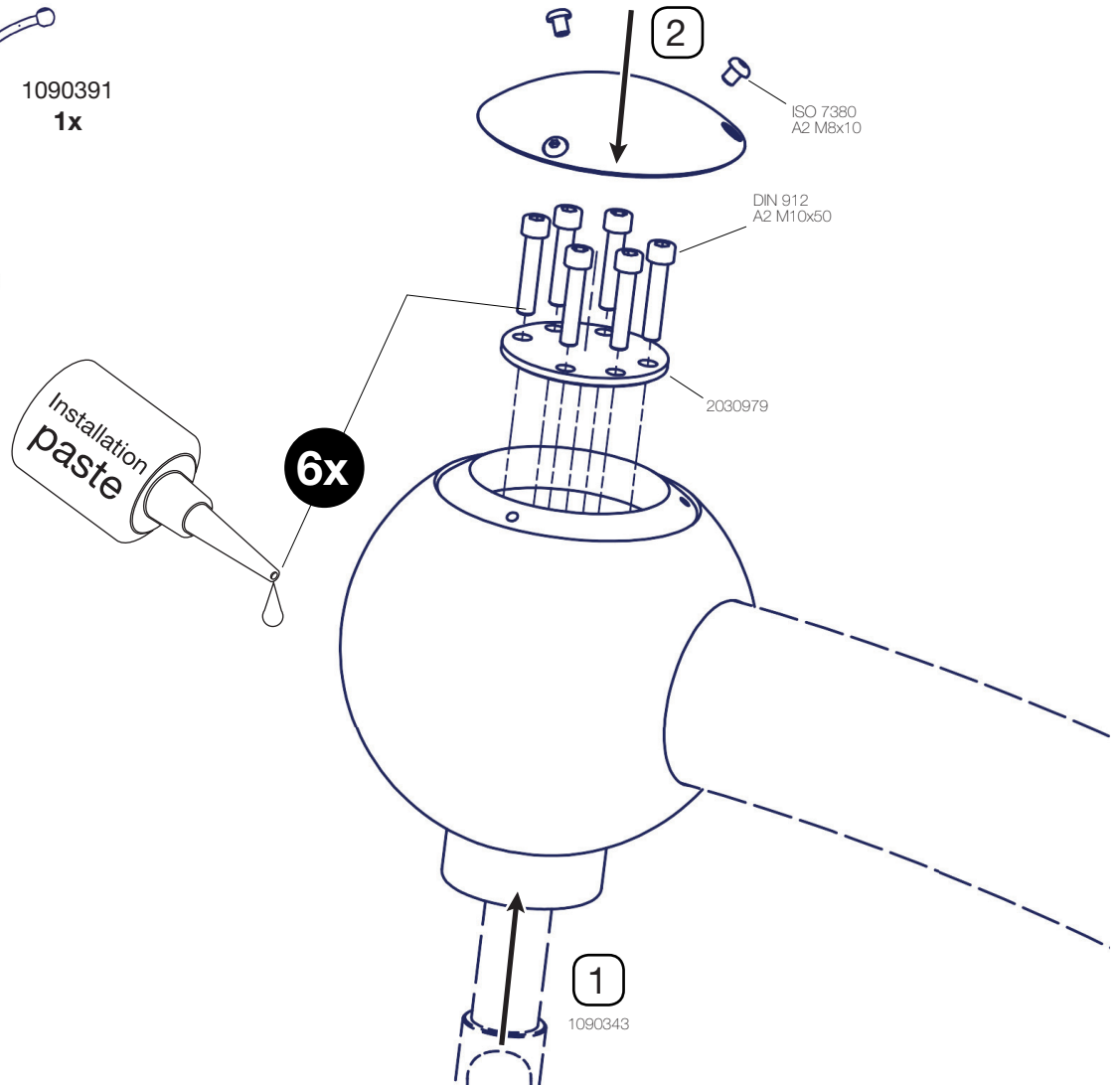
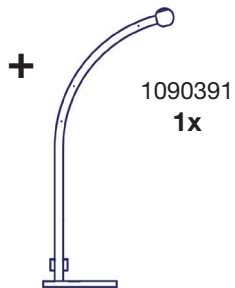

Step 9



24 mm



min.
2,5 m

+



1090351
1x

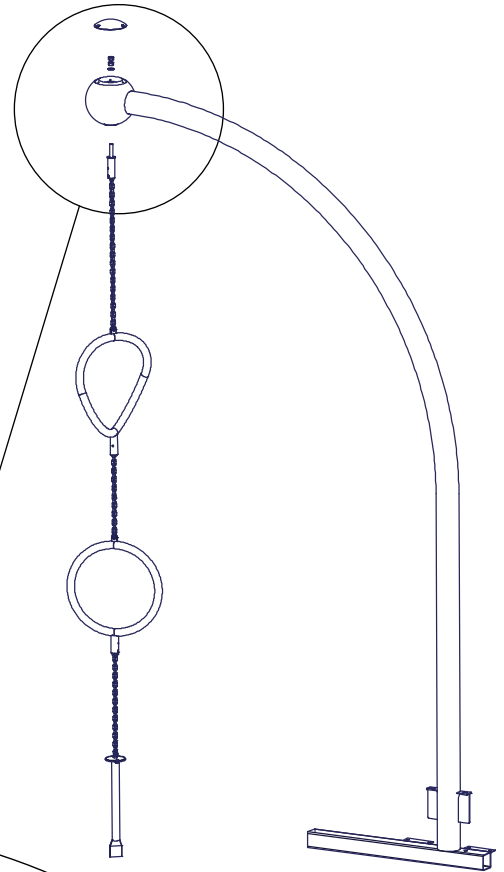

2



ISO 7380
A2 M8x10

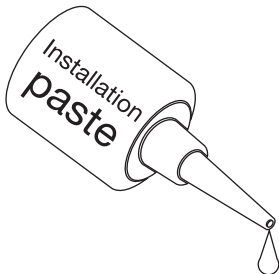

1x



1090351

1

