

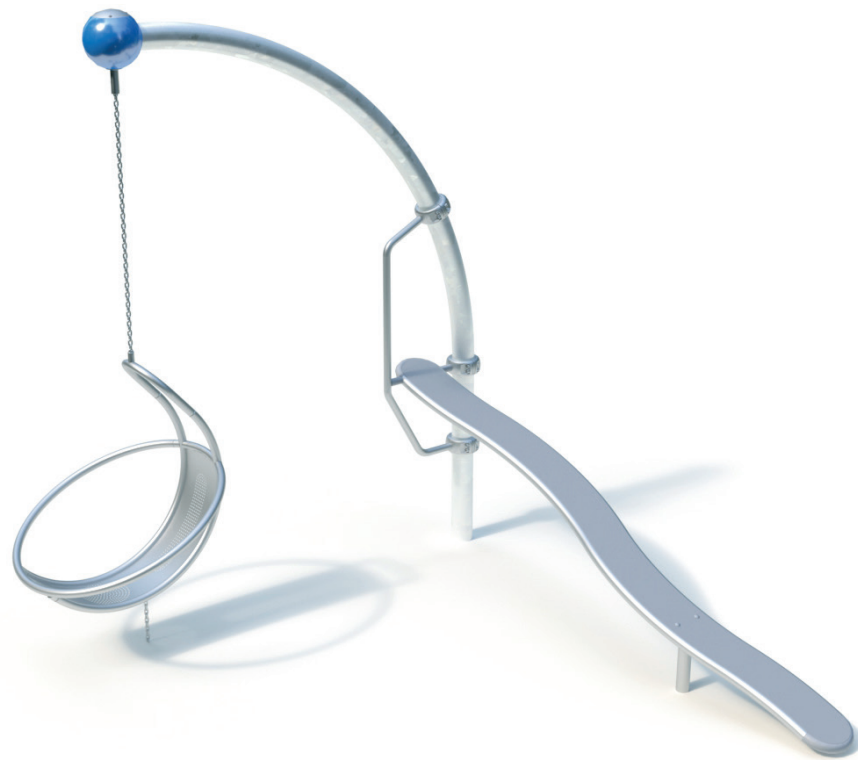

INSTALLATION

0-27115-001

Actio 115



Werkzeuge tools

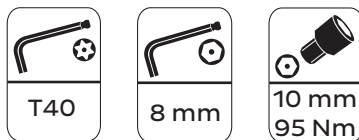

Kaiser & Kühne



customer

Montageanweisungen Installation instructions

DE

1. Gerätestandort unter Berücksichtigung des Platzbedarfs (Aufprallfläche) festlegen.
2. Bodenaushub für Fundamente nach Zeichnung vornehmen. Bitte beachten Sie: Für eine stand-sichere Montage werden mittelschwer lösbare Bodenarten vorausgesetzt.
3. Ca. 10 cm dicke Grobkiesschicht als Drainschicht zwischen Unterseite der Standpfosten und der Fundamentsohle einbringen.
4. Rohrbogenstütze in das jeweilige Fundamentloch stellen.
5. Bauteile lose verschrauben.
6. Zum Einbauen der vormontierten Bauteile bzw. Einzelteile müssen die Schrauben mit der gelie-ferten Montagepaste leicht gefettet werden. Erst nach dem Ausrichten alle Schrauben fest anziehen.
7. Fundamente mit Stampfbeton C20/25 füllen, und mit einem Bodenmaterial abdecken, dessen kritische Fallhöhe größer gleich der maximalen freien Fallhöhe ist (s. EN 1176-1).
8. Freigabe zum Bespielen erst nach Abbinden der Betonfundamente.
9. Alle Schraubverbindungen gemäß Wartungs-anleitung nach 4-5 Wochen überprüfen und ggf. fest nachziehen.

Alle mit dem Gerät gelieferten Spezialwerk-zeuge (z.B. Innensechskant- Schlüssel für gesicherte Schrauben etc.) sowie alle gerä-tespezifischen Unterlagen, die für das Sicherheitsmanagement nach EN 1176-7 wichtig sind oder sein könnten wie z.B. Rechnung, Lieferschein oder Auftrags-bestätigung, Montageanleitung und Wartungsanleitung im Original oder in einer Kopie an die zuständigen Stellen weiterleiten.

Bitte beachten Sie:

Um einen sicheren und unfallfreien Spielbetrieb mit diese Gerät zu gewährleisten, müssen die im Wartungsplan aufgeführten Tätigkeiten unbed-ingt ausgeführt werden.

Vor dem Anziehen der Schraubverbindungen unbedingt alle Anbauteile einsetzen. Ein nach-trägliches Einsetzen ist NICHT möglich!

GB

1. Assign a device location considering the space requirements (impact area).
2. Excavate soil for foundations, according to drawing. Please note: To achieve maximum stability and a safe installation, a moderate level of soil solubility is required.
3. Pour in a drain layer of gravel of approx. 10 cm thickness between the bottom of the posts and plain base of foundation.
4. Place posts into the respective foundation hole.
5. Gently tighten component parts.
6. For installation of the pre-assembled components and/or single parts, the screws slightly have to be lubricated with installation paste! Tighten all screws after having aligned all components.
7. Grout foundations with compressed concrete C20/25, cover the foundations with a surface which meets the requirements for impact attenuation so that the critical fall height of the surfacing is equal to, or greater than, the free height of fall of the equipment (acc. to EN 1176-1).
8. Release for play after concrete foundations have set.
9. According to maintenance instructions, check all screw connections after 4-5 weeks and retighten, if necessary.

Please ensure that all special tools supplied (e.g. Allen key for secured Allen screws etc.) and all specific documents which are or may be useful for safety management acc. to EN 1176-7 (e.g. invoice, delivery note, order acknowledgement, installation instructions, maintenance instructions) are forwarded to the persons responsible.

Please note:

For safe playing circumstances without accidents, it is essential to execute the scale of operations listed in the maintenance schedule.

Necessarily insert all attachment parts before tightening the screws. It is NOT possible to insert them afterwards.

**Geräteraum
space occupied by
equipment**

2,58 x 3,19 x 2,93 m

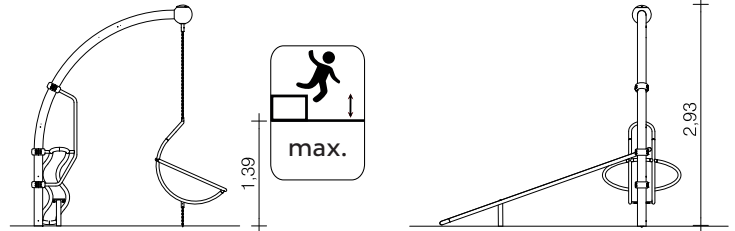

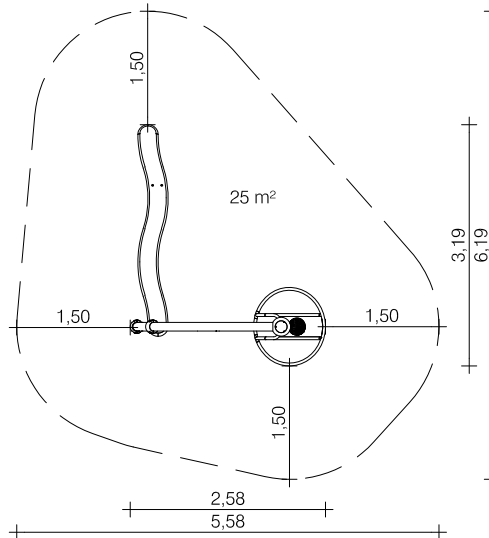

**Mindestraum
minimum space**

5,58 x 6,19 x 2,93 m

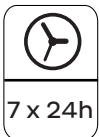
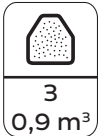

**Fundamentplan
foundation plan**





ATTENTION



Zuerst alle Anbauteile einbauen, ausrichten und alle Schrauben anziehen.
Danach Fundamente entsprechend den Darstellungen mit Stampfbeton C20/25 herstellen.

At first install all components, align their and tighten all screws.
Then growth foundations with compressed concrete C20/25 according to the illustrations.

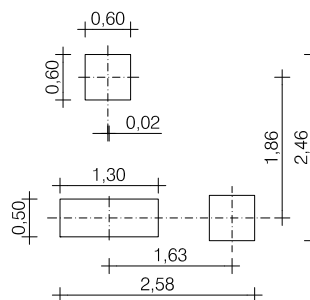
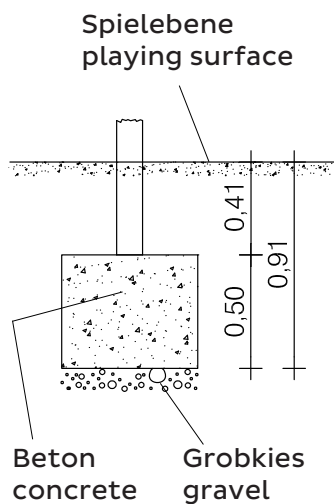

**Komponenten
components**

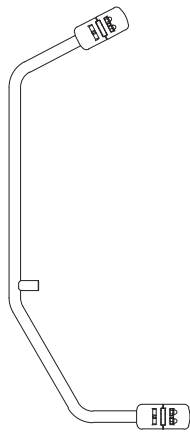
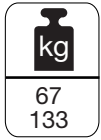

①
1090426
1x



②
1090423
1x

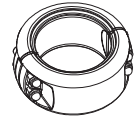

③
2030534
1x

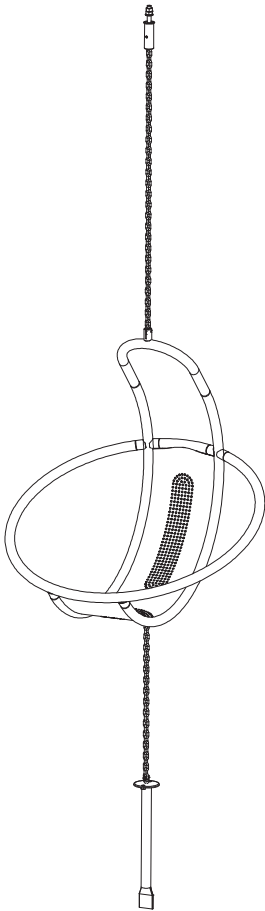

⑤
1090345
1x

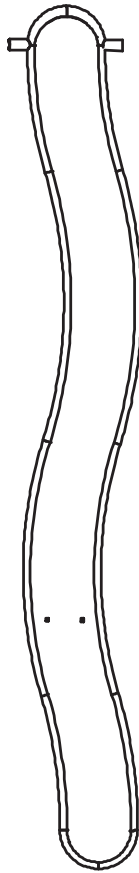



⑥
1090533
1x

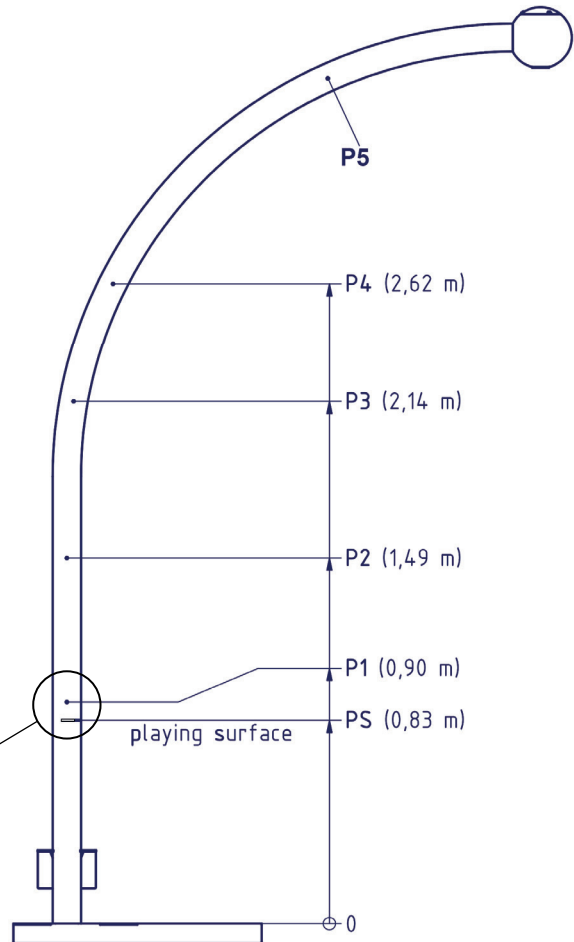

④
1092859
1x



Step 1

- +  1090533 1x
- +  2030534 1x
- +  1090423 1x

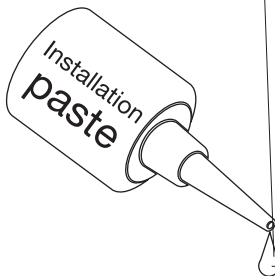
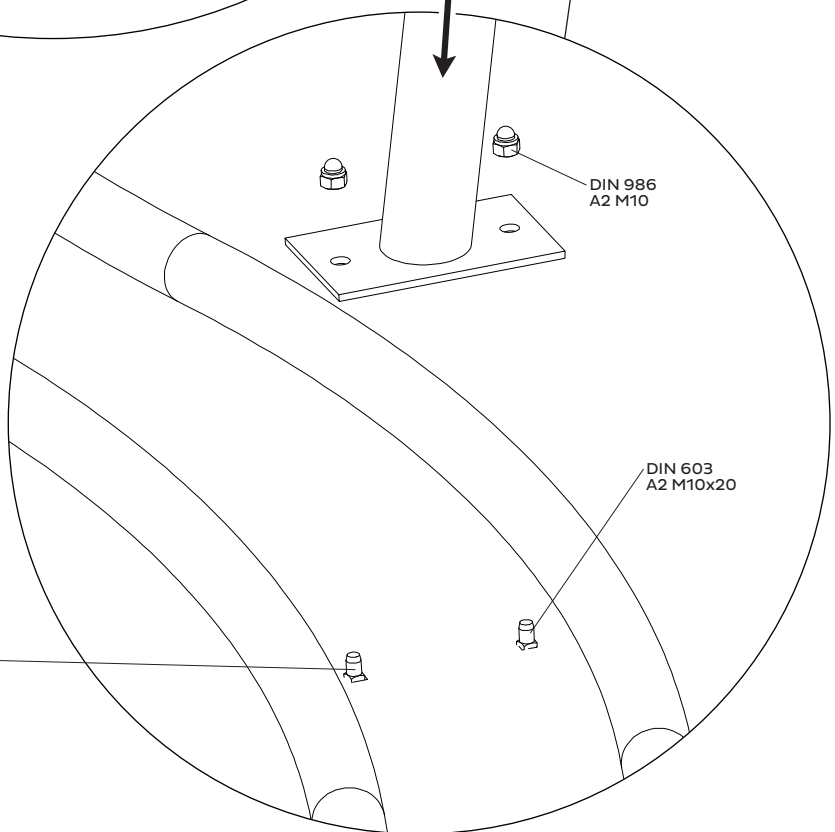
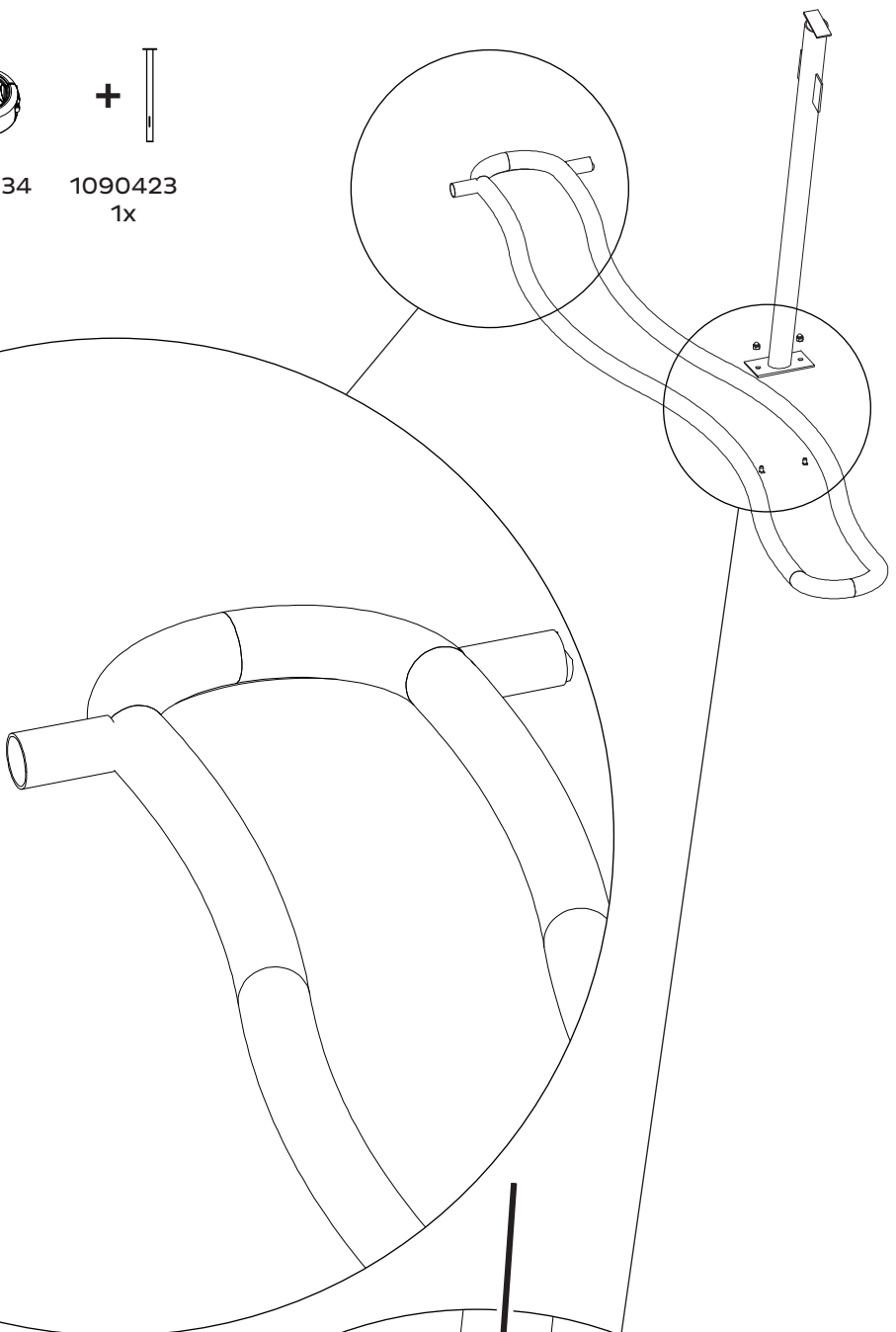
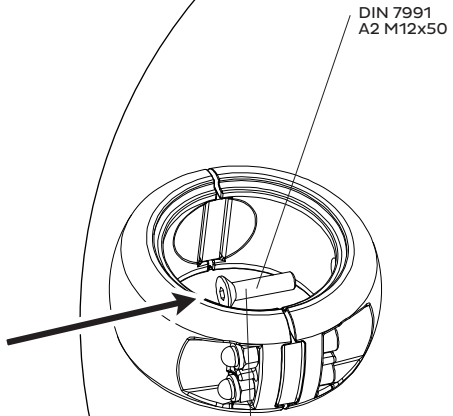
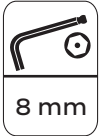

2x

Step 2

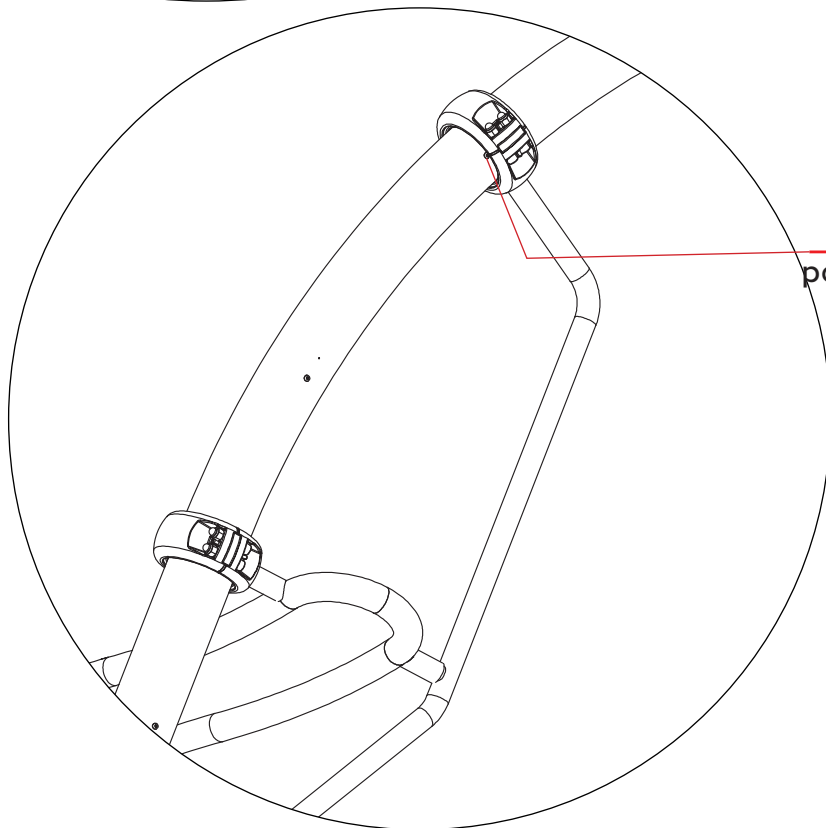
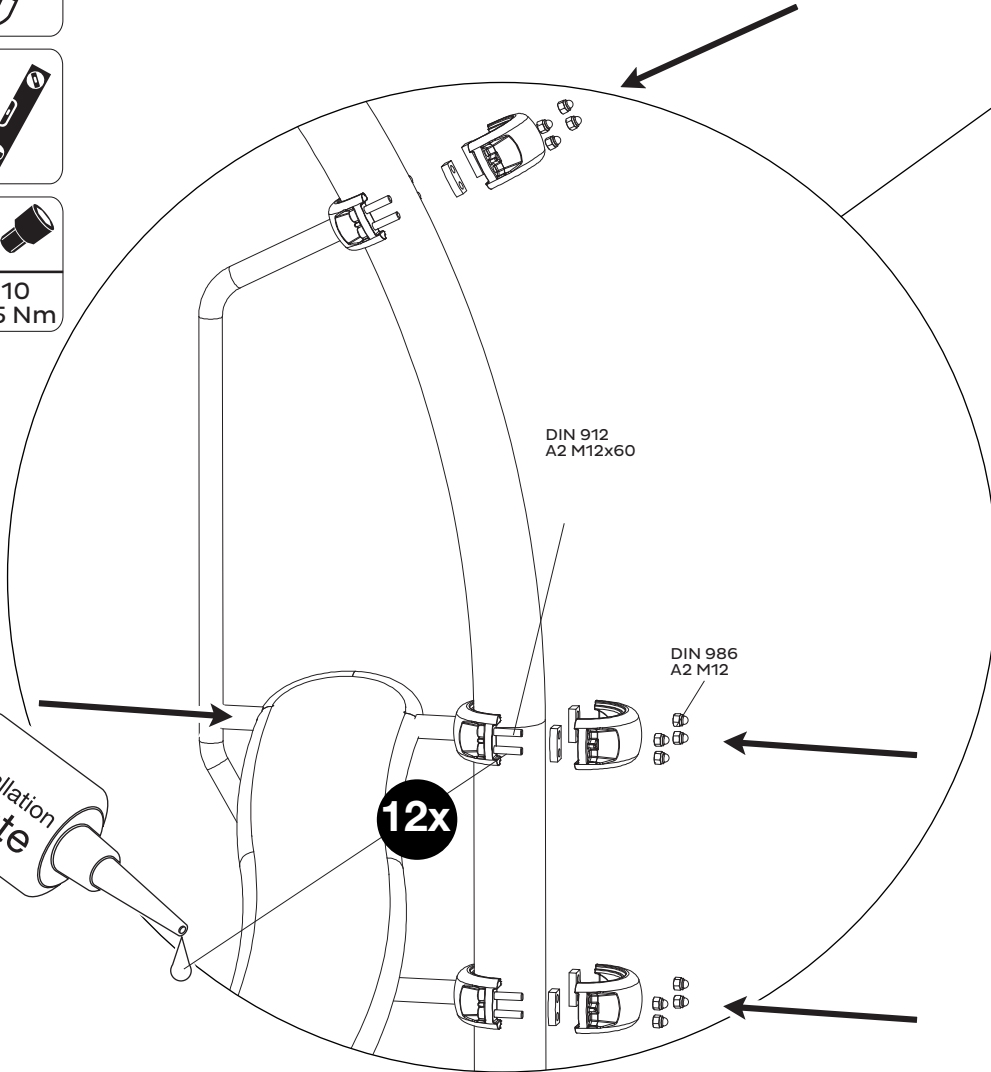
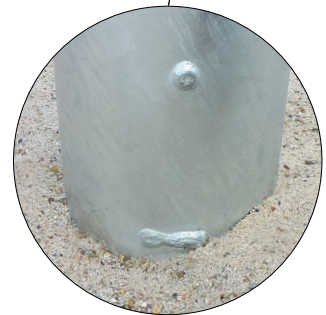
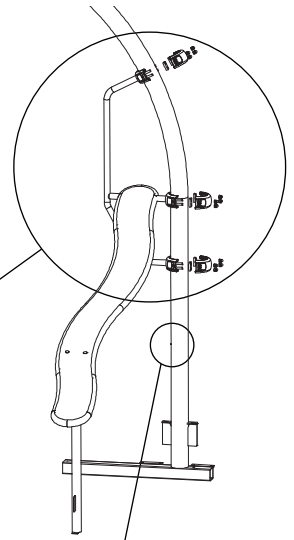
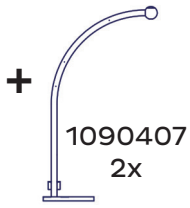
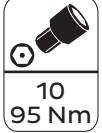

Step 3



24 mm



min.
2,5 m

+



1090351
1x

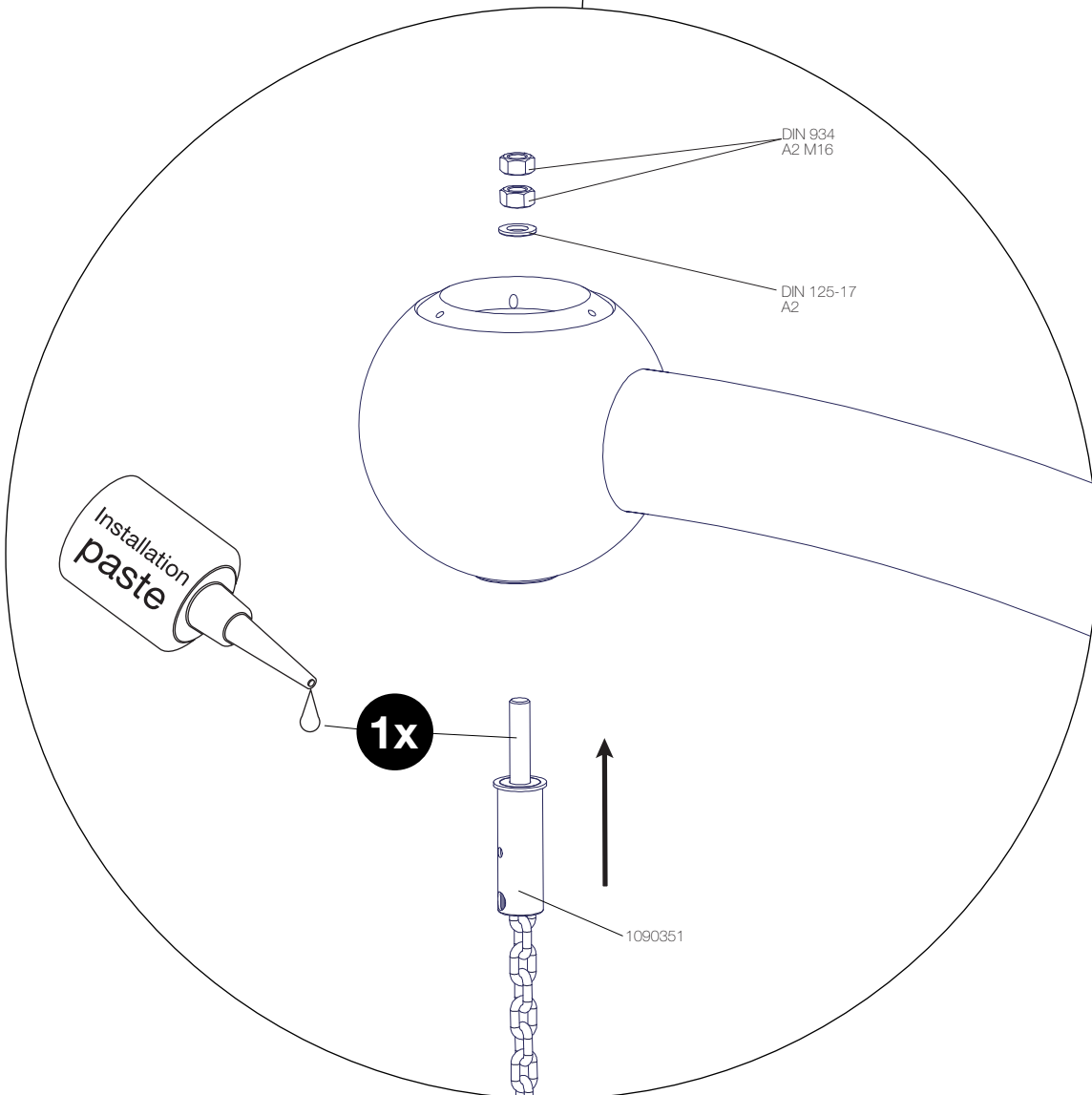
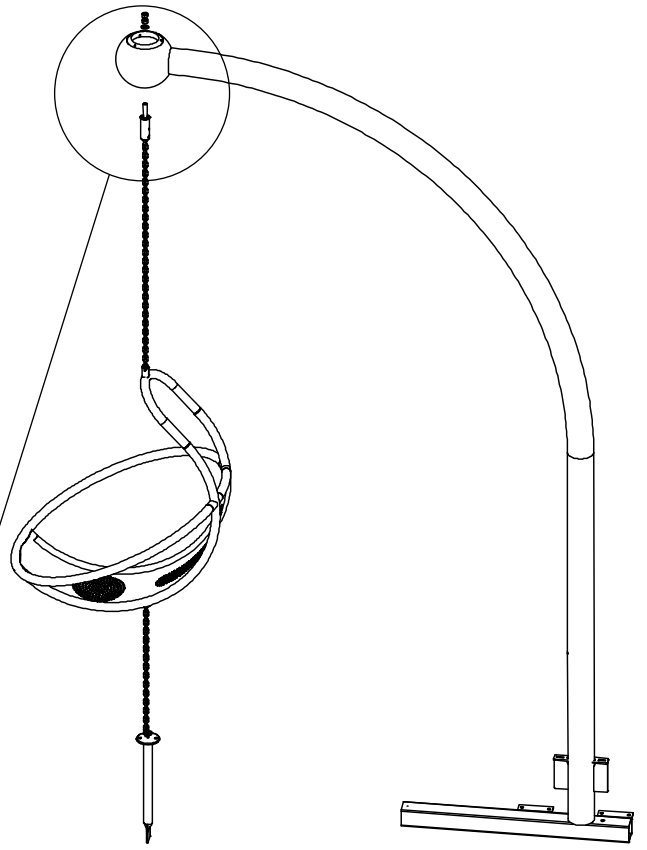



Zuerst alle Anbauteile einbauen, ausrichten und alle Schrauben anziehen.

Danach Fundamente entsprechend den Darstellungen mit Stampfbeton C20/25 herstellen.

At first install all components, align their and tighten all screws.

Then growth foundations with commpressed concrete C20/25 according to the illustrations.