

1. Assign a device location considering the space requirements (impact area). Slide direction recommended: north-east or in half-shade of trees.
2. Excavate soil for foundations, according to drawing.  
Please note: To achieve maximum stability and a safe installation, a moderate level of soil solubility is required.
3. Pour in a drain layer of gravel of approx. 10 cm thickness between the bottom of the posts and plain base of foundation.
4. Insert reinforcing steel into the corresponding holes of the posts.
5. Place posts type A (see foundation layout) into the respective foundation hole, according to the corresponding number. Play level mark (=aluminium blind rivet) complies with the installation depth. Align every post by means of the play level mark facing into the same direction (see detail or foundation layout).
- 6. For installation of the pre-assembled components and/or single parts, the screws slightly have to be lubricated with installation paste!**  
Screw together platforms and posts by using the respective hole in the mounting brackets (according to chart).  
**Tighten all screws after having aligned all components.**  
Install the slide exit with an inclination of 5° in sliding direction.  
Screw connections see details in attached list.
7. Grout foundations with compressed concrete C20/25, chamfer and round off the edges, cover the foundations with a surface which meets the requirements for impact attenuation so that its critical fall height is equal to or greater than the maximum free height of fall of the equipment (acc. to EN 1176-1). The run-out section fall zone must have surfacing with a critical fall height of at least 1000 mm (acc. to EN 1176-3).
8. Release for play after concrete foundations have set.
9. According to maintenance instructions, check all screw connections after 4-5 weeks and retighten, if necessary.

Please ensure that all special tools supplied (e.g. Allen key for secured Allen screws etc.) and all specific documents which are or may be useful for safety management acc. to EN 1176-7 (e.g. invoice, delivery note, order acknowledgement, installation instructions, maintenance instructions) are forwarded to the persons responsible.

**Necessarily insert all attachment parts before tightening the screws. It is NOT possible to insert them afterwards.**

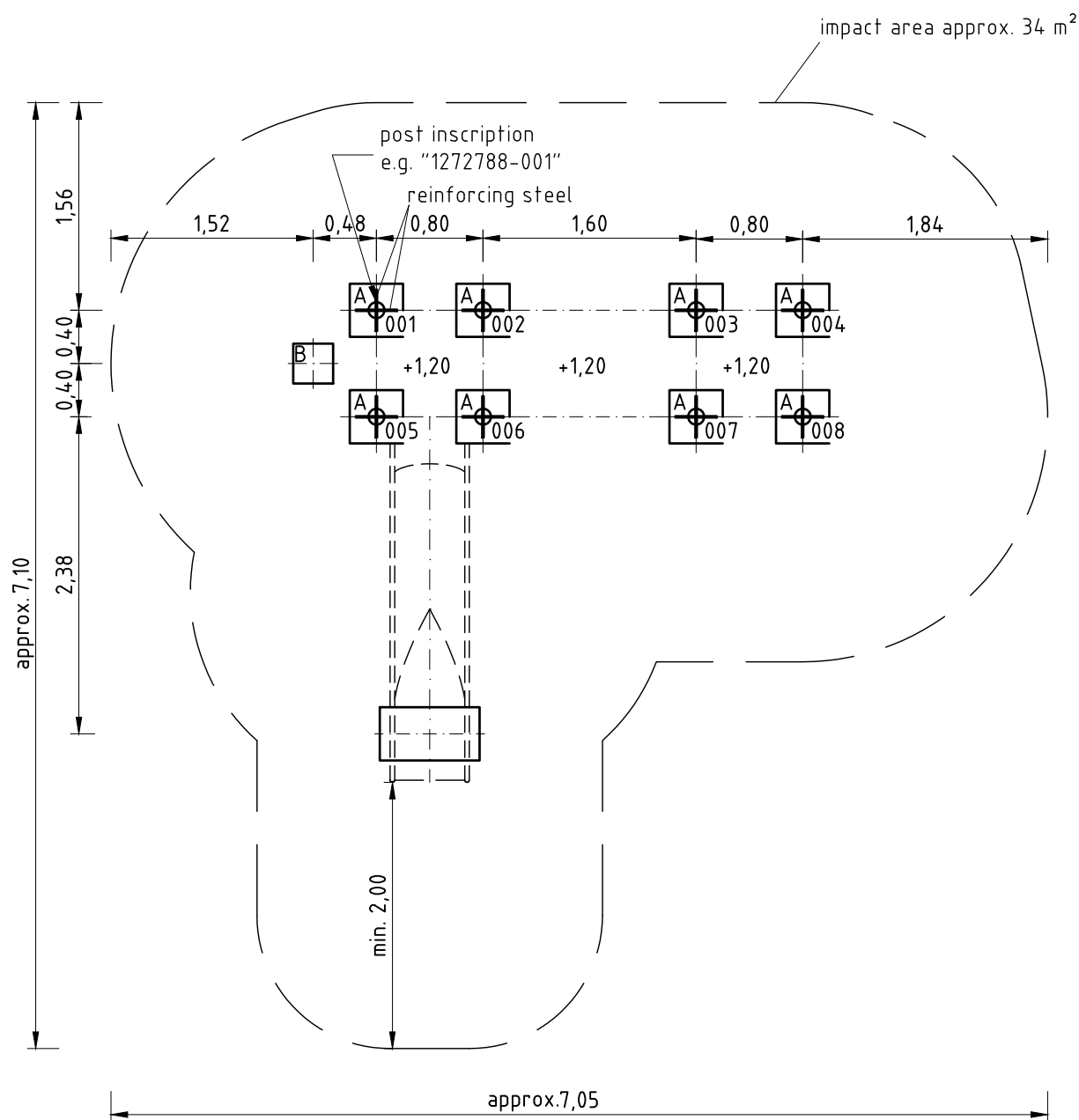

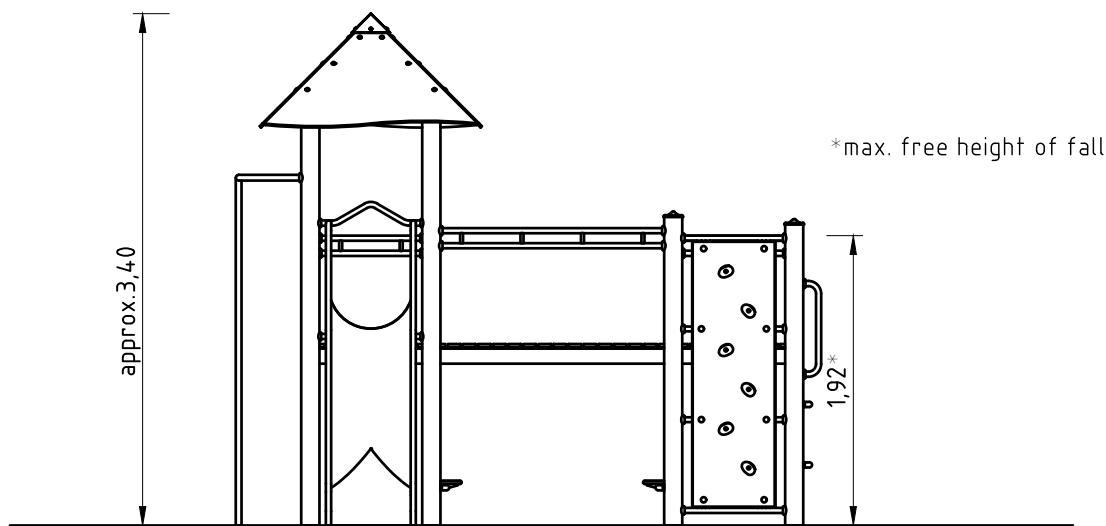
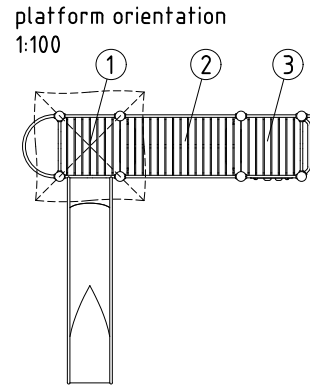
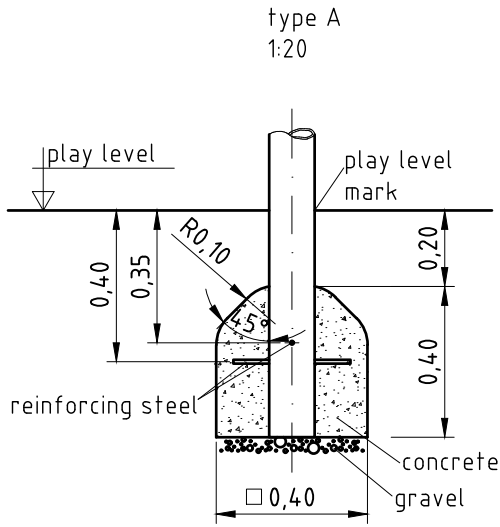
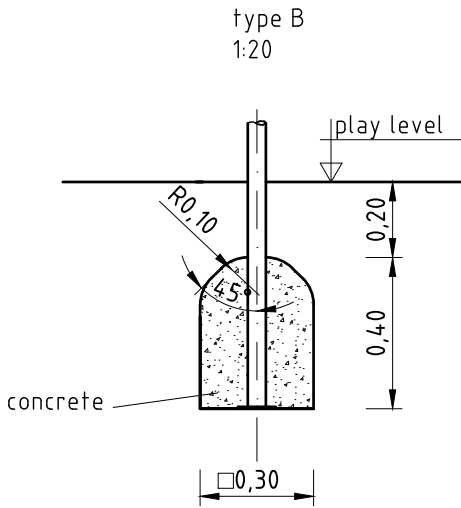
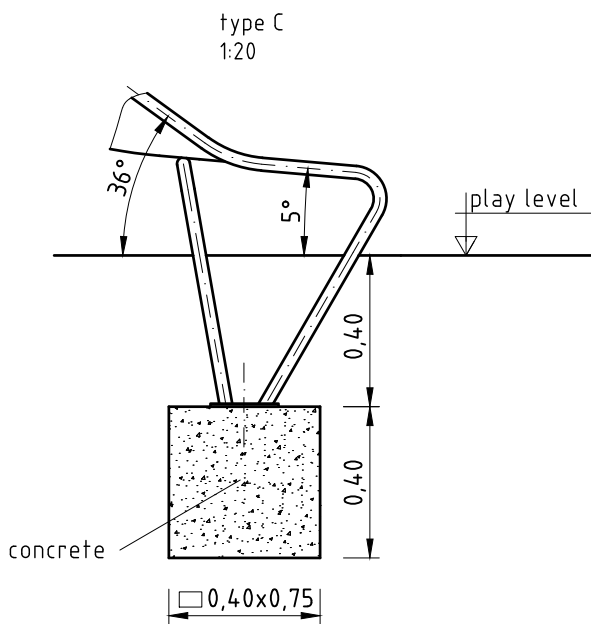
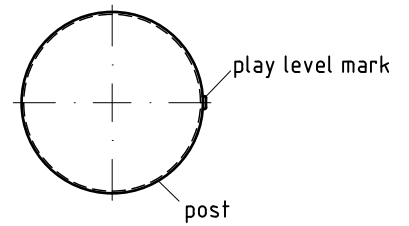

chart for platform fastenings

platform No.	fastening hole		
	top	middle	bottom
1		x	
2	x		
3		x	



detail of play level mark  
1:5



platform fastening  
1:10

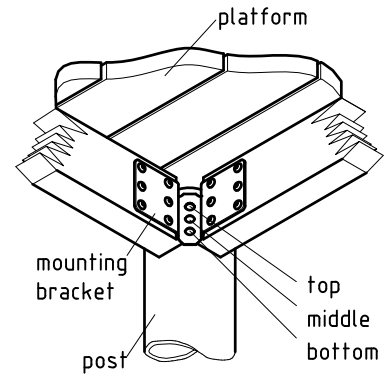

Item: **021640500**  
 K&K Play structure  
 Location:

Order:

1292049

Building Project:

**12 x SFES1200001 Fixing of platform at stainless steel post nut on platform site**

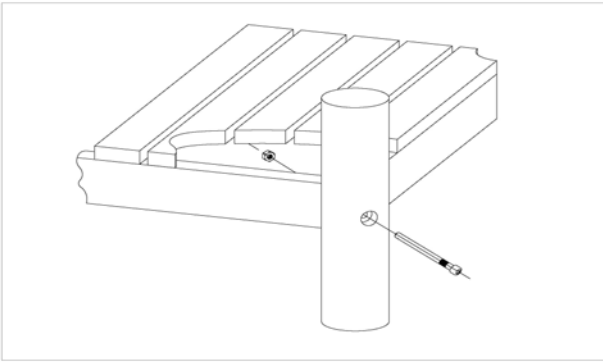

per SC	Total	K&K-Item	Marking
1 x	12 x	3430021	Lock nut M12 DIN985 A2
1 x	12 x	2030651	Cheese head screw M12 x 125 with pin and blue colour mark

**48 x SFES1210001 Standard bolting of add-on pieces for fastening of ES120 add-on pieces at steel posts (except platforms)**

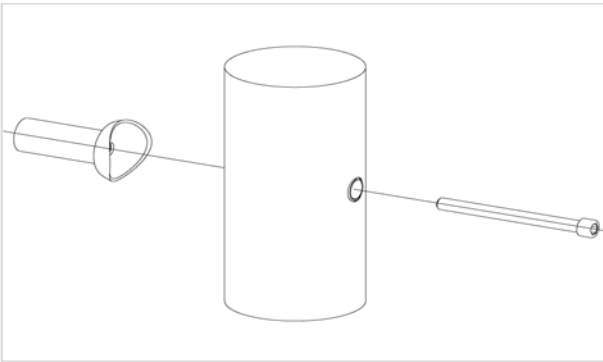

per SC	Total	K&K-Item	Marking
1 x	48 x	2030168	Cheese head screw M12x140 with pin for fastening of ES120-add-on pieces at steel posts (except platforms)

**1 x SFAS1240007 Tent roof 4 x 0.8 m with lantern tower HPL plates at stay tubes and lantern tower at HPL plates**

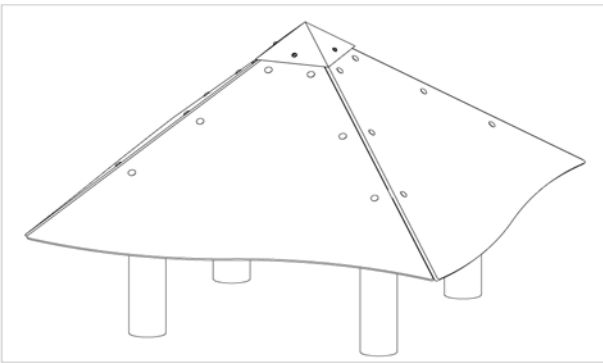

per SC	Total	K&K-Item	Marking
24 x	24 x	3430011	Hexagon cap nut M10 DIN986 A2
24 x	24 x	3430014	Washer Ø 10,5 DIN 125 B A2
4 x	4 x	3400673	Dome head security bolt M8 x 20 Resistorx A2
4 x	4 x	3430102	Washer Ø 8.4 DIN9021 A2
24 x	24 x	3400138	Mushroom head screw square neck M10x30 DIN 60

**1 x SFAS1070006 Slide run-out section (up to 2,00 m) on foundation stone bolt assembly**

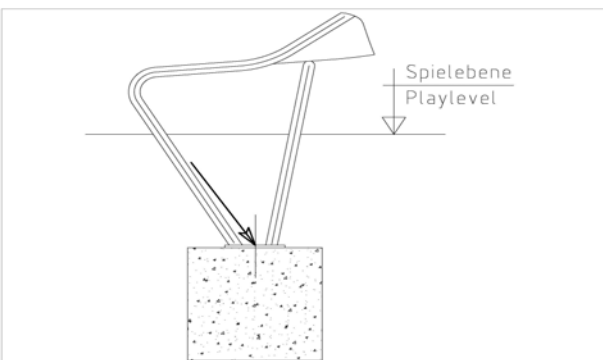

per SC	Total	K&K-Item	Marking
2 x	2 x	1070365	Set of stone bolts for slide run-out section M12x160

Item: **021640500**  
 K&K Play structure  
 Location:

Order:

1292049

Building Project:

**8 x SFES1270001 Reinforcing steel for stainless steel posts**

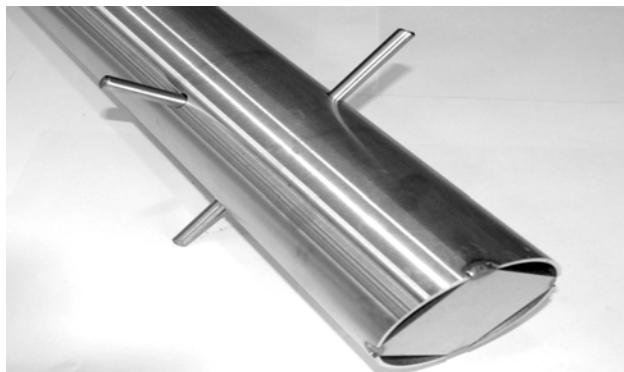

per SC	Total	K&K-Item	Marking
2 x	16 x	2130000	Reinforcing steel Ø 10 x 310 DIN 488

**1 x SFWZ0000001 Security TORX wrench TR40**



per SC	Total	K&K-Item	Marking
1 x	1 x	3490081	Security TORX wrench TR40

**1 x SFWZ0000009 Hexagon insert socket driver 10mm 1/2" with borehole for Pin**



per SC	Total	K&K-Item	Marking
1 x	1 x	2030170	Hexagon insert socket driver 10 mm 1/2" with drill hole for Pin

**1 x SFWZ0000012 Lubricating metal (30g box) incl. brush**



per SC	Total	K&K-Item	Marking
1 x	1 x	5300039	Lubricating metal box à 30g
1 x	1 x	5200026	Brush for lubricating metal