

- Assign a device location considering the space requirement (impact area). Slide direction recommended: north-east or in half-shade of trees.
- Excavate soil for foundations, according to drawing.  
Please note: To achieve maximum stability and a safe installation, a moderate level of soil solubility is required.
- Pour in a drain layer of gravel of approx. 10 cm thickness between the bottom of the tubular pedestals and plain base of foundation.
- Insert reinforcing steel into the corresponding hole of the tubular pedestal.
- Place posts type A and B (see foundation layout) according to the corresponding number into the respective foundation hole. Play level mark (=aluminium blind rivet) complies with the installation depth. Align every post by means of the play level mark facing into the same direction (see detail or foundation layout).
- For installation of the pre-assembled components and/or single parts, the screws slightly have to be lubricated with installation paste!**  
Screw together platforms and posts by using the respective hole in the mounting brackets (according to chart).  
**Tighten all screws after having aligned all components.**  
Install the slide exit with an inclination of 5° in sliding direction.  
Screw connections see details in attached list  
We recommend not to insert the protection caps enclosed before first maintenance as they are only suitable for one-time use (see description in item No. 9).
- Grout foundations with compressed concrete C20/25, chamfer and round off the edges, cover the foundations with a surface which meets the requirements for impact attenuation so that the critical fall height of the surfacing is equal to, or greater than, the free height of fall of the equipment (acc. to EN 1176-1). The run-out section fall zone must have surfacing with a critical fall height of at least 1000 mm (acc. to EN 1176-3).
- Release for play after concrete foundations have set.
- According to maintenance instructions, check all screw connections after 4-5 weeks and retighten, if necessary. Afterwards cover the screw heads with protection caps as follows: Insert grey protection caps into the countersunk drills (e.g. for platforms). The non-countersunk drills (e.g. for railings or a slide) have to be covered with the red protection caps by placing them onto the base part. Strongly pound them (e.g. by using a plastic mallet) until they audibly snap into the base part groove.

Please ensure that all special tools supplied (e.g. Allen key for secured Allen screws etc.) and all specific documents which are or may be useful for safety management acc. to EN 1176-7 (e.g. invoice, delivery note, order acknowledgement, installation instructions, maintenance instructions) are forwarded to the persons responsible.

**Necessarily insert all attachment parts before tightening the screws.  
It is NOT possible to insert them afterwards.**

platform orientation/numbers  
1:100

chart platform fastening

platform-no.	fastening hole		
	top	middle	bottom
1		x	
2		x	
3		x	
4		x	
5	x		
6		x	
7		x	

platform fastening  
1:10play level mark  
1:5



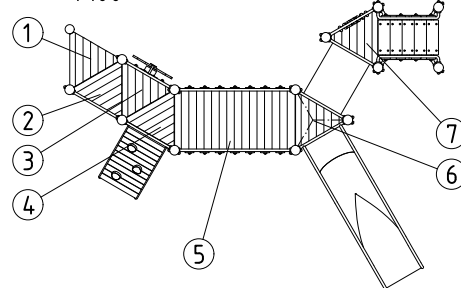
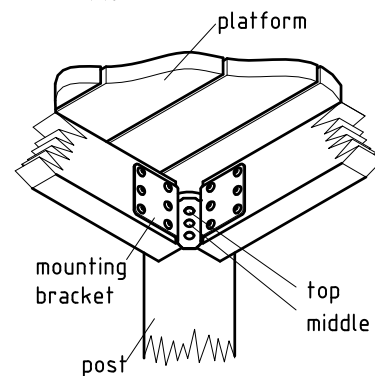
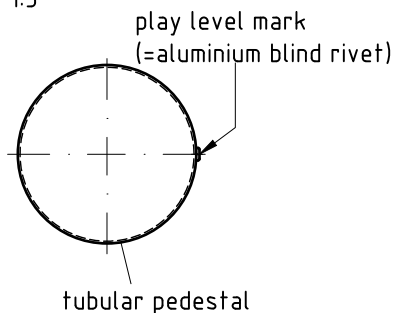
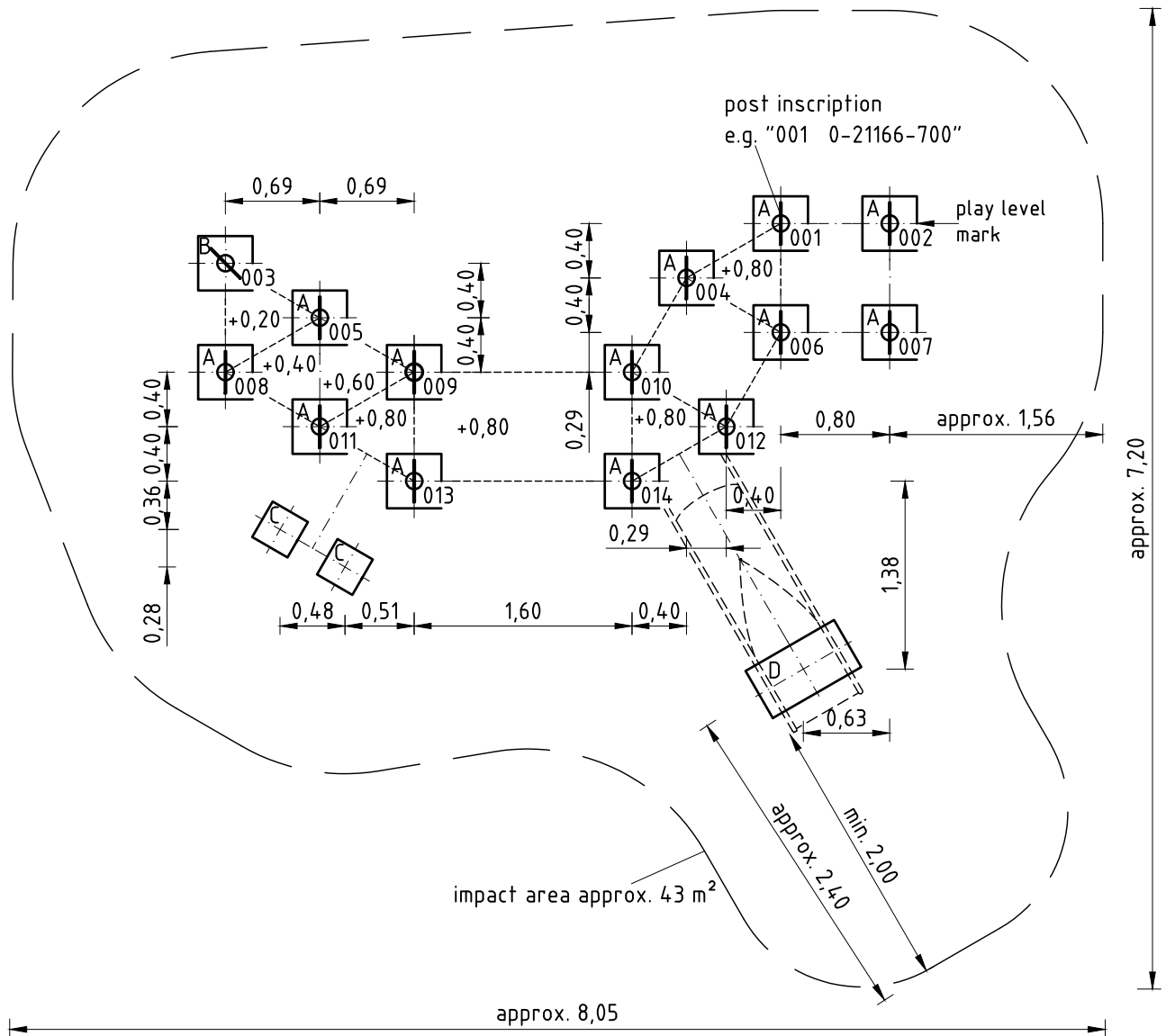
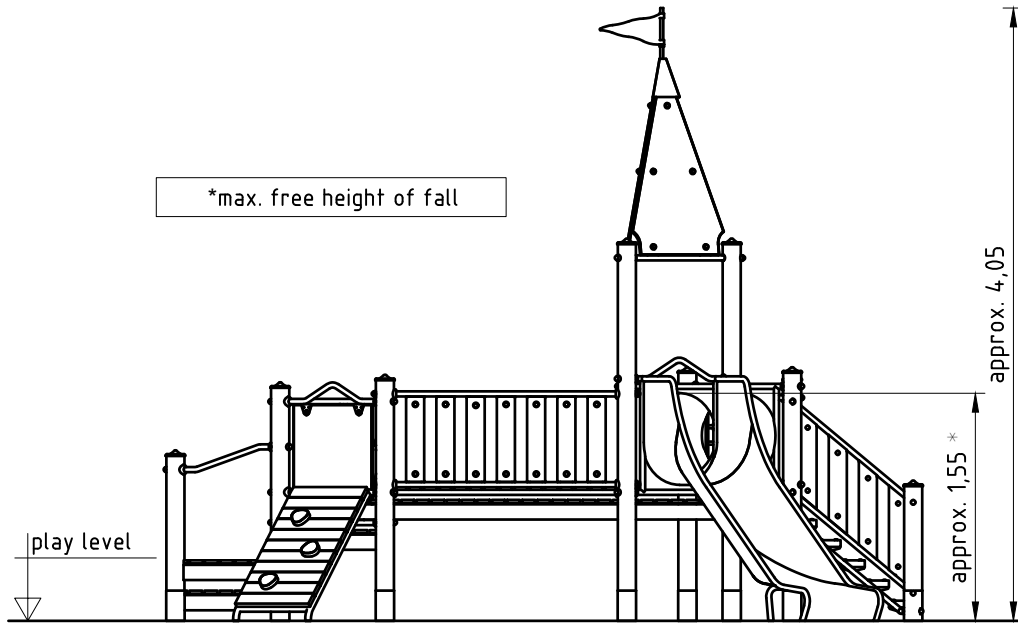
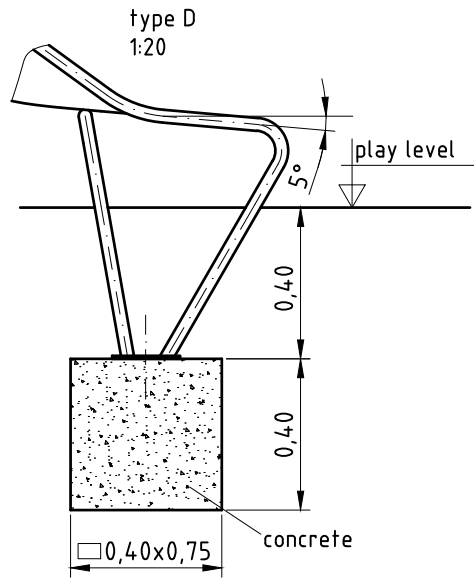
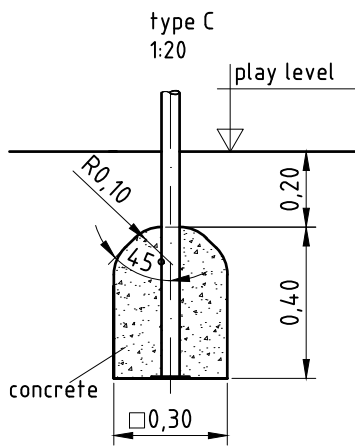
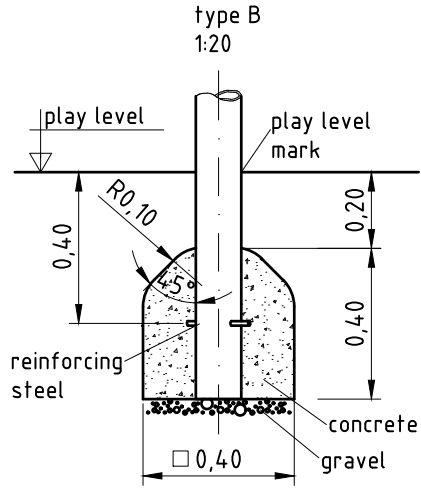
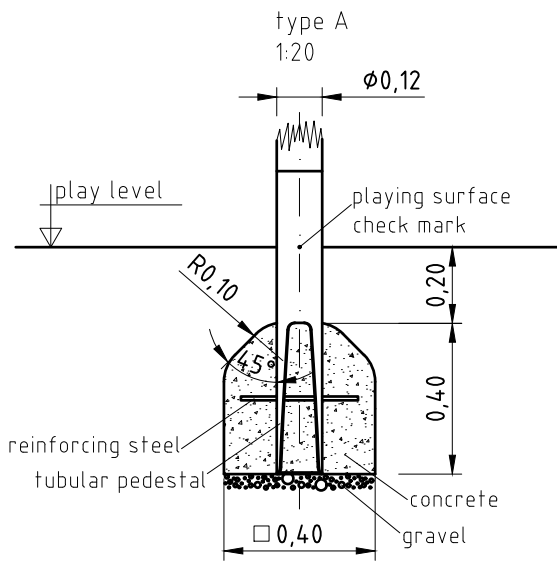

Item: **021166700**  
 K&K Play structure  
 Location:

Order:

1299078

Building Project:

**1 x SFES1200014 Platform at stainless steel post/tubular support  
 (Hexagon screw with red cap/nut platform-site)**

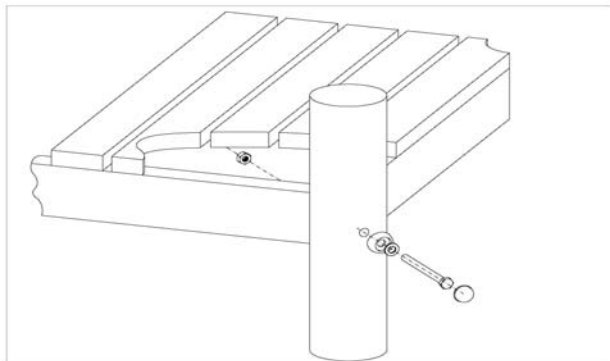

per SC	Total	K&K-Item	Marking
1 x	1 x	3430025	Washer Ø 13 DIN125 A2
1 x	1 x	3300055	red protective screw cap - upper part, domed M12
1 x	1 x	3300054	red protective screw cap - lower part, domed M12
1 x	1 x	3430021	Lock nut M12 DIN985 A2
1 x	1 x	3400363	Hexagon head cap screw M12 x 150 DIN931 A2

**21 x SFRS1200001 Platform at Robinia post, nut is platform-sided**

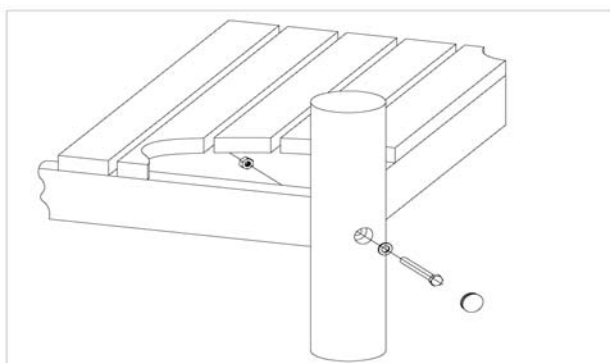

per SC	Total	K&K-Item	Marking
1 x	21 x	3300016	Grey domed plastic cover cap SL 36 G
1 x	21 x	3400700	Hexagon head screw M12 x 120 DIN931 A2 with screw security coating/FGB red
1 x	21 x	3430129	Washer Ø 14 DIN1440 A2
1 x	21 x	3430021	Lock nut M12 DIN985 A2

**46 x SFRS1210001 Standard bolting of barriers, handrails, slides to Robinia posts**

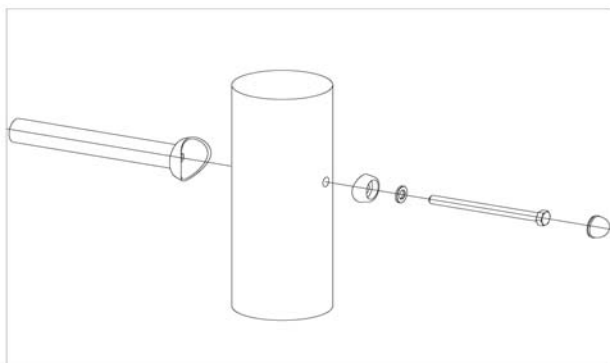

per SC	Total	K&K-Item	Marking
1 x	46 x	3300054	red protective screw cap - lower part, domed M12
1 x	46 x	3300055	red protective screw cap - upper part, domed M12
1 x	46 x	3430025	Washer Ø 13 DIN125 A2
1 x	46 x	3400702	Hexagon head cap screw M12 x 160 DIN931 A2 with screw security coating FGB red

**3 x SFRS1240002 Roof frame spire roof 80° with flag**

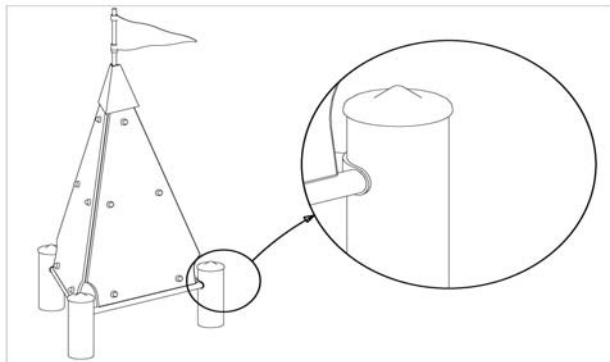

per SC	Total	K&K-Item	Marking
1 x	3 x	3400363	Hexagon head cap screw M12 x 150 DIN931 A2
1 x	3 x	3300055	red protective screw cap - upper part, domed M12
1 x	3 x	3300054	red protective screw cap - lower part, domed M12
1 x	3 x	3430051	Hexagon cap nut M12 DIN 986 A2
2 x	6 x	3430025	Washer Ø 13 DIN125 A2

Item: **021166700**  
 K&K Play structure  
 Location:

Order:

1299078

Building Project:

**1 x SFAS1070006 Slide run-out section (up to 2,00 m) on foundation stone bolt assembly**

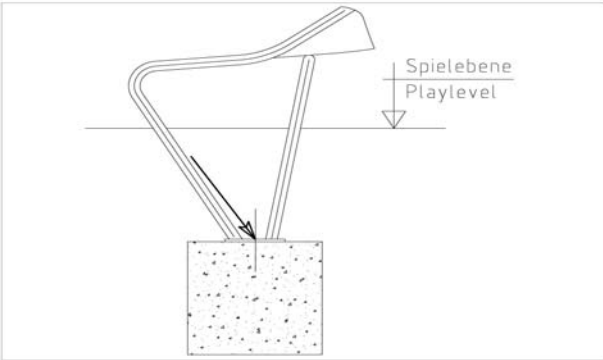

per SC	Total	K&K-Item	Marking
2 x	2 x	1070365	Set of stone bolts for slide run-out section M12x160

**13 x SFES1270007 Reinforcing steel for tubular pedestals**



per SC	Total	K&K-Item	Marking
1 x	13 x	2130000	Reinforcing steel Ø 10 x 310 DIN 488

**1 x SFRS1270002 Reinforcing steel for stainless steel posts**



per SC	Total	K&K-Item	Marking
1 x	1 x	2130000	Reinforcing steel Ø 10 x 310 DIN 488

**1 x SFWZ0000012 Lubricating metal (30g box) incl. brush**



per SC	Total	K&K-Item	Marking
1 x	1 x	5300039	Lubricating metal box 30g
1 x	1 x	5200026	Brush for lubricating metal