

detail of play level mark  
1:5

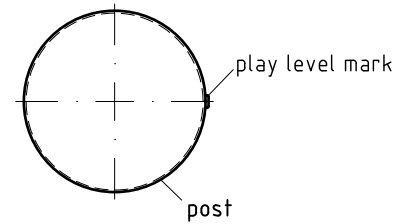

platform orientation/numbers  
1:100

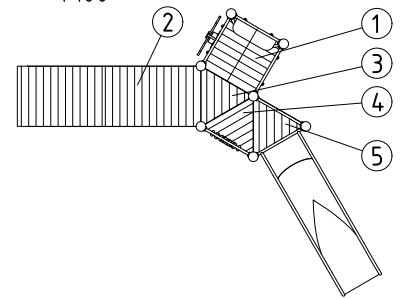

1. Assign a device location considering the space requirements (impact area). Slide direction recommended: north-east or in half-shade of trees.
2. Excavate soil for foundations, according to drawing.  
Please note: To achieve maximum stability and a safe installation, a moderate level of soil solubility is required.
3. Pour in a drain layer of gravel of approx. 10 cm thickness between the bottom of the posts and plain base of foundation.
4. Insert reinforcing steel into the corresponding holes of the posts.
5. Place posts type A according to the corresponding number (see foundation layout) into the respective foundation hole. Play level mark (=aluminium blind rivet) complies with the installation depth. Align every post by means of the play level mark facing into the same direction (see detail or foundation layout).

**6. For installation of the pre-assembled components and/or single parts, the screws slightly have to be lubricated with installation paste!**

Screw together platforms and posts by using the respective hole in the mounting brackets (according to "**chart for platform fastenings**").

**Tighten all screws after having aligned all components.**

Install the slide exit with an inclination of 5° in sliding direction.

Screw connections see details in attached list.

7. Grout foundations with compressed concrete C20/25, chamfer and round off the edges, cover the foundations with a surface which meets the requirements for impact attenuation so that the critical fall height of the surfacing is equal to, or greater than, the free height of fall of the equipment (acc. to EN 1176-1). The run-out section fall zone must have surfacing with a critical fall height of at least 1000mm (acc. to EN 1176-3).
8. Release for play after concrete foundations have set.
9. According to maintenance instructions, check all screw connections after 4-5 weeks and retighten, if necessary.

Please ensure that all special tools supplied (e.g. Allen key for secured Allen screws etc.) and all specific documents which are or may be useful for safety management acc. to EN 1176-7 (e.g. invoice, delivery note, order acknowledgement, installation instructions, maintenance instructions) are forwarded to the persons responsible.

**Necessarily insert all attachment parts before tightening the screws. It is NOT possible to insert them afterwards.**





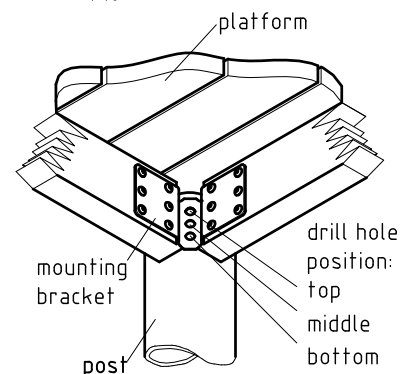
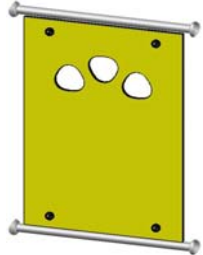

chart for platform fastenings





No.	height	drill hole position in mounting bracket		
		top	middle	bottom
①	0,60		x	
②	0,60			x
③	0,60	x		
④	0,60			x
⑤	0,80		x	



platform fastening  
1:10



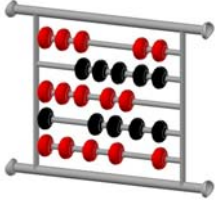

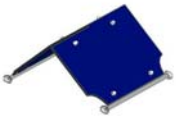
<u>Parts list</u>		021160500	GB
item no.	quantity	description	image
1272093	1	set of 7 pcs. of stainless steel posts with stainless steel post cap / blue RAL 5015	
1200004	3	triangular platform 3 x 0,80 m	
1200000	1	square platform 0,80 m x 0,80 m	
1210004	1	infill panel 0,80 m x 0,80 m / red HPL	
1210185	1	infill panel 0,80 m x 0,90 m / yellow HPL 3 cutouts	
1230234	1	ramp 0,80 m x 2,40 m x 0,60 m	

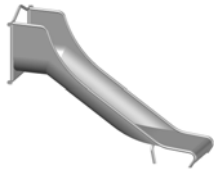
<u>Parts list</u>		021160500	GB
item no.	quantity	description	image
1210373	1	entrance guardrail 0,80 m	 A silver metal guardrail with a curved top and two vertical posts.
1210359	1	horizontal bar/ladder rung 0,80 m	 A single silver metal horizontal bar.
1210019	1	slide rule 0,80 x 0,60 m	 A slide rule with a red frame and black and red beads on a white background.
1210060	1	infill panel with wheel of fortune / red HPL	 A red square panel with a yellow wheel of fortune in the center, numbered 1-12.
1220021	1	bench seat type 1 / 0,80 m / yellow HPL	 A yellow bench seat with a curved backrest.
1240074	1	pitch roof 0,80 m x 0,80m / royal blue HPL	 A royal blue square panel with a small protrusion on one side.

<u>Parts list</u>		021160500	GB
item no.	quantity	description	image
041409001	1	K&K Trough-shaped attachment slide (0,80)	
1299076	1	fastening kit for 0211600500	

Item: **021160500**

Order:

1299076

Play structure

Location:

Building Project:

**10 x SFES1200001 Platform fastening to stainless steel post, nut on the side of the platform**

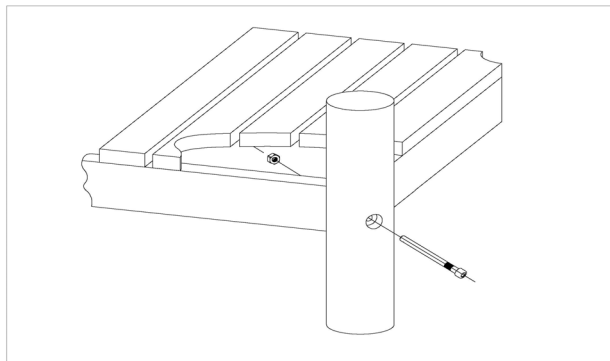

per SC	Total	K&K-Item	Marking
1 x	10 x	3430021	Lock nut M12 DIN985 A2
1 x	10 x	2030651	Cheese head screw with pin M12 x 125

**5 x SFES1200004 Platform at stainless steel posts screw fixed by manufacturer**

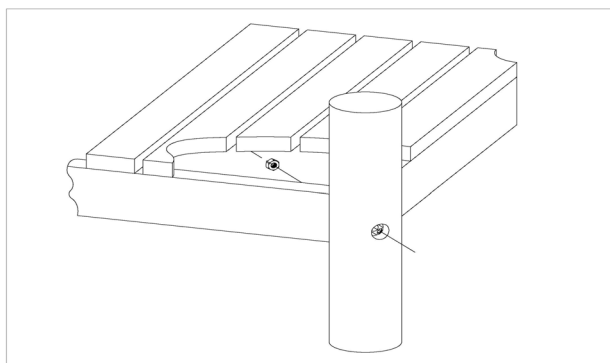

per SC	Total	K&K-Item	Marking
1 x	5 x	3430021	Lock nut M12 DIN985 A2

**32 x SFES1210001 Standard bolting of attachment parts (except platforms) to stainless steel posts**

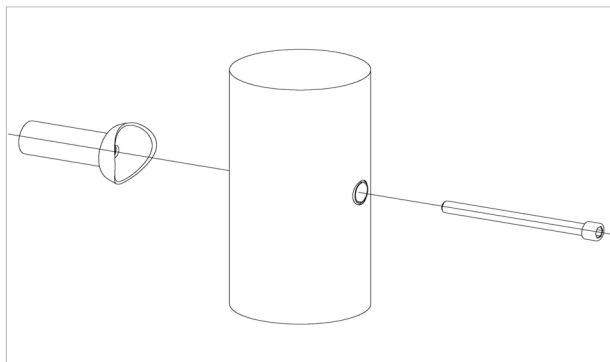

per SC	Total	K&K-Item	Marking
1 x	32 x	2030168	Cheese head screw with pin M12x140

**1 x SFAS1240002 Ridge roof 0,80 m x 0,80 m HPL panel fastening on double clips (bottom-sided)**

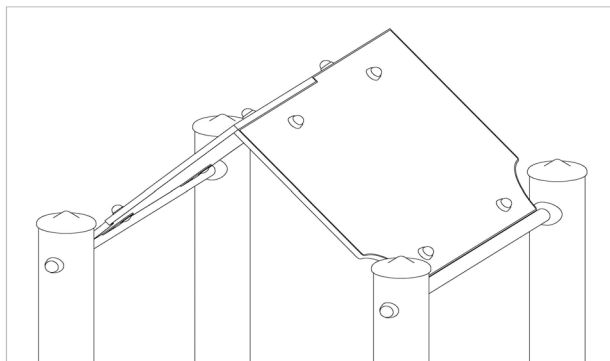

per SC	Total	K&K-Item	Marking
4 x	4 x	3300056	white protective screw cap - lower part, M10
4 x	4 x	3430014	Washer Ø 10,5 DIN125 form B A2
4 x	4 x	3400024	Mushroom head screw M10 x 35 DIN603 A2
4 x	4 x	3430048	Lock nut M10 DIN985 A2
4 x	4 x	3300057	white protective screw cap - upper part, M10
2 x	2 x	6240003	double clip for tent roofs (angled at 90°)

Item: **021160500**

Order:

1299076

Play structure

Location:

Building Project:

**1 x SFXS1070006 Slide run-out section (up to 2,00 m) on foundation stone bolt assembly**

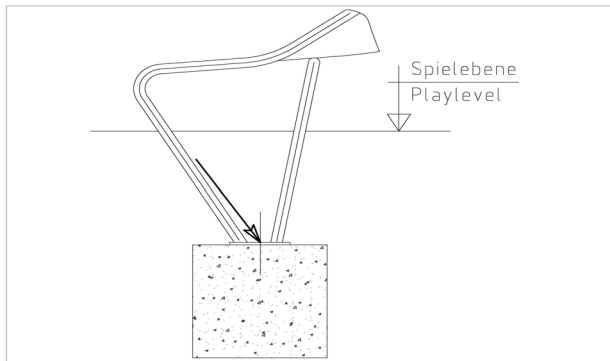

per SC	Total	K&K-Item	Marking
2 x	2 x	1070365	Set of stone bolts for slide run-out section M12x160

**7 x SFES1270001 Reinforcing steel for stainless steel posts**



per SC	Total	K&K-Item	Marking
2 x	14 x	2130000	Reinforcing steel Ø 10 x 310 DIN 488

**1 x SFXS1230010 Steel pedestal at wooden ramp**

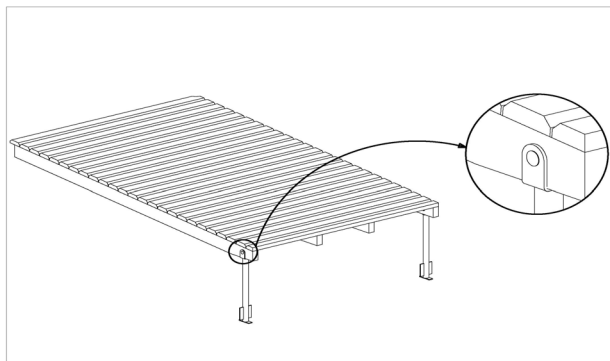

per SC	Total	K&K-Item	Marking
2 x	2 x	3430048	Lock nut M10 DIN985 A2
2 x	2 x	3430014	Washer Ø 10,5 DIN125 form B A2
2 x	2 x	3400416	Mushroom head screw M10 x 65 DIN603 A2

**1 x SFWZ0000009 Hexagon insert socket driver 10mm 1/2" with borehole for Pin**



per SC	Total	K&K-Item	Marking
1 x	1 x	2030170	Hexagon insert socket driver 10 mm 1/2" with drill hole for Pin

Item: **021160500**

Order:

1299076

Play structure

Location:

Building Project:

**1 x SFWZ0000012 Lubricating metal (30 g box) incl. brush**



per SC	Total	K&K-Item	Marking
1 x	1 x	5300039	Lubricating metal box 30g
1 x	1 x	5200026	Brush for lubricating metal